



Chapter

9.1



A consistent approach to finishes

This chapter gives guidance on meeting the Technical Requirements for finishes in new homes.

9.1.1	Compliance	01
9.1.2	External walls	01
9.1.3	Internal walls and ceilings	04
9.1.4	Doors and windows	05
9.1.5	Floors	06
9.1.6	Glazing	07
9.1.7	Ceramic, concrete, terrazzo and similar tile finishes	07
9.1.8	Fitted furniture	07
9.1.9	Joint sealants	08
9.1.10	Paint finishes	08
9.1.11	Sanitary ware	08
9.1.12	Other surfaces and finishes	08
9.1.13	Pitched roof coverings	09
9.1.14	Garages	09
9.1.15	External works	09
9.1.16	Further information	09

For figure reference tables, please go to the end of each chapter.



9.1.1 Compliance

Also see: Chapter 2.1

Finishes shall comply with the Technical Requirements.

Finishes that comply with the guidance in this chapter will generally be acceptable.

This guidance:

- is intended to apply when the home is substantially complete and ready for NHBC pre-handover inspection
- will be used by NHBC both during the construction process and when conducting resolutions under section 2 of the Buildmark insurance cover
- should be considered in conjunction with relevant performance standards and guidance contained elsewhere within NHBC Standards
- uses tolerances and finishes considered to be appropriate for the house-building industry and takes precedence over other recommendations
- is not intended to deal with every situation which may arise, and discretion should be exercised.

Some elements may be subject to the effects of normal thermal or drying movement, and this may occur both before and after completion.

Some materials are not uniform and are not intended to be; this includes reclaimed materials. Some colour and texture variation is inevitable; this is often used as an aesthetic feature and should be recognised in appropriate tolerances or considered separately. Acceptability of finished appearances will be in the opinion of NHBC.

The nature and extent of work necessary to remedy minor variations from the tolerances and finishes given should be proportionate and appropriate to the circumstances: for example, how readily visible or extensive the affected part of the construction is.

9.1.2 External walls

Also see: Chapter 6.11

External walls shall have an acceptable finished appearance. Issues to be taken into account include:

- | | |
|------------------------|-------------------------|
| a) fair faced masonry | e) brick slip cladding |
| b) render | f) timber cladding |
| c) curtain walling | g) tile hanging |
| d) rainscreen cladding | h) cast stone elements. |

Tolerances and appearance should be considered:

- for the entire wall (eg panels and interfaces), and not for the individual elements of the construction, such as individual bricks, individual bed joints, or design features and details (eg quoins, soldier courses and plinths)
- in daylight, and from a minimum distance of 10m.

Fair faced masonry

Fair faced masonry should:

- be reasonably uniform in texture, finish and colour, including mortar
- not have excessive colour banding
- not have significant cracks in the facing bricks or other damage, such as chips and marks greater than 15mm in diameter.

Where a fair faced finish can only be achieved on one side (such as half brick walls), the other faces should be left neat and tidy.

Also note:

- some mortar blemishes will occur on individual masonry units
- some variation will occur in the texture, finish and colour of mortar, in individual masonry units and generally over the wall
- efflorescence occurs naturally in some types of masonry. It is not harmful and generally disappears over time
- some brick products have features or marks which may be in excess of 15mm in diameter
- some minor shrinkage cracking may occur between masonry units (bricks and blocks) and mortar joints.

Fair faced masonry should meet the following tolerances:

- adequately straight on plan, with a $\pm 8\text{mm}$ maximum deviation in any length of wall up to 5m
- adequately straight in section, with a tolerance of $\pm 8\text{mm}$ per storey height (up to 3m)
- a maximum of 8mm from plumb in any storey up to 3m. Taller walls should be a maximum of 8mm from plumb per storey and 12mm in total
- a maximum deviation of 4mm over 1m at external reveals.

Figure 1: Straightness in plan for fair faced masonry

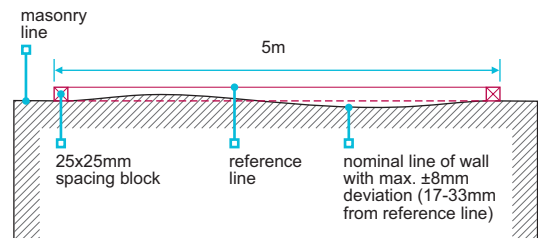

straightness in plan

Example:
Using 25mm wide spacing blocks, the masonry line should be 17-33mm from the reference line.

Spacing block dimensions are a guide, and final dimensions should ensure the reference line is kept clear of the wall face.

Figure 2: Straightness in section for fair faced masonry

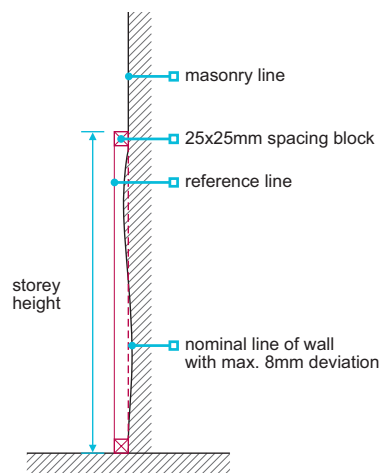

straight in section

Example:
Using 25mm wide spacing blocks, the masonry line should be 17-33mm from the reference line.

Spacing block dimensions are a guide, and final dimensions should ensure the reference line is kept clear of the wall face.

Figure 3: Plumb in section for fair faced masonry

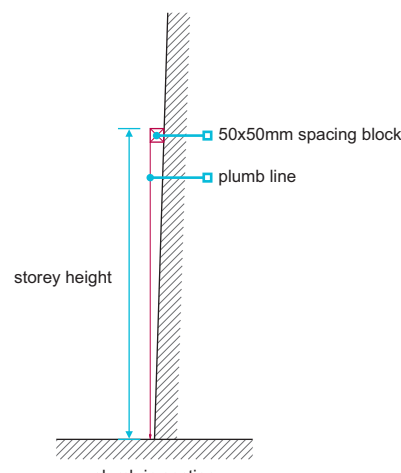

plumb in section

Example:
Using 50mm wide spacing blocks, the plumb bob should be 42-58mm from the wall, measured at between 2.5-3m from the spacing block.

Note:
Spacing block dimensions are a guide, and final dimensions should ensure the plumb line is kept clear of the wall face.

Figure 4: Straightness at reveals for fair faced masonry

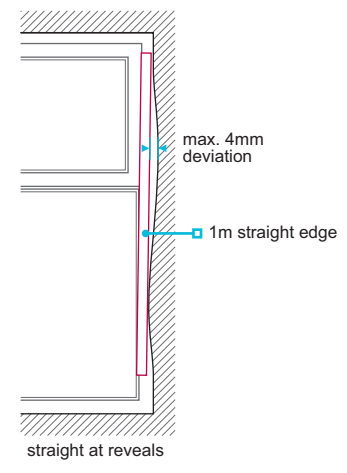

straight at reveals

Bed joints should be reasonably straight, measured along the top of a given row of bricks, with:

- a maximum deviation from straightness of $\pm 8\text{mm}$ in any 5m section of wall.

The thickness of an individual bed joint should not vary from the average of the next eight successive joints by a maximum of $\pm 1.5\text{mm}$.

Figure 5: Straightness of bed joints in fair faced masonry

Straightness of bed joints

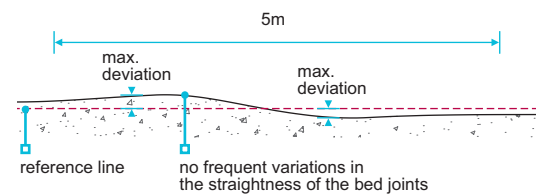

Example of how to determine if bed joint thickness is acceptable

Measure and add 8 successive bed joints and divide by 8 to determine the average size:

$$11+10+12+10+11+9+11+10 = 84$$

$$\text{Divide by } 8 = 10.5\text{mm}$$

Therefore, the acceptable range of the bed joint below the 8 measured bed joints is 9-12mm.

Perpend joints should not cumulatively displace in the same direction for more than 5 joints. The centre line of any perpend joint should generally be within $\pm 15\text{mm}$ of the centre line of the next 5 successive perpend joints.

Also note:

- to achieve setting out, perp joints in masonry panels between openings may be offset with the perp joints in the panels above and below. The joints within the panel should not cumulatively displace.

Render

Render should:

- be reasonably consistent in texture, finish and colour
- be flat, within a maximum $\pm 4\text{mm}$ vertical and horizontal deviation in 5m
- be free from crazing (a set of hairline cracks, generally less than 1mm in depth and no more than 0.2mm wide).

Also note:

- there may be some colour variation in appearance due to differences in suction of the background and orientation of the wall
- daywork joints, patching and other repairs may be visible but should not be unduly obtrusive
- some localised hairline cracking is likely to occur in both traditional render and proprietary render systems. Such cracking and crazing should not impair the performance of the home
- areas of render in close proximity to features (eg bell casts) are excluded from the tolerance
- flatness is measured in a similar way to straightness and plumb of masonry.

Figure 6: Straightness in section for render

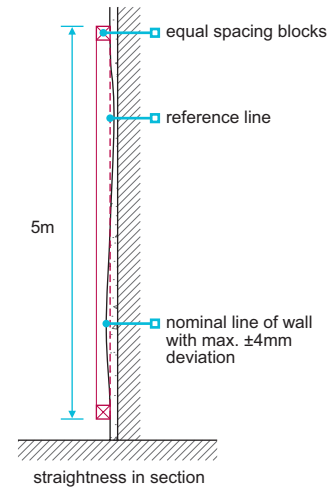

Example:
Using 25mm wide spacing blocks, the masonry line should be 21-29mm from the reference line.
Spacing block dimensions are a guide, and final dimensions should ensure the plumb line is kept clear of the wall face.

Curtain walling

Curtain walling should be within:

- reasonable tolerances and appearance for the materials
- a maximum deviation of $\pm 2\text{mm}$ in any storey height or structural bay width, and $\pm 5\text{mm}$ overall, unless otherwise specified in the design.

Rainscreen cladding

Rainscreen cladding should be within:

- reasonable tolerances and appearance for the materials
- a maximum deviation of $\pm 3\text{mm}$ in any storey height or structural bay width, unless otherwise specified in the design.

Brick slip cladding

Brick slip cladding should meet the same tolerances as fair faced masonry.

Timber cladding

Variation in colour may occur in uncoated timber exposed to the weather, and the rate and extent may vary.

Also note:

- the effects of normal weathering over time may cause uncoated timber to develop a silver/grey colour
- variations in the weathering of uncoated timber cladding may occur as a result of building features such as projecting sills and roof overhangs.

Tile hanging

Panels should be reasonably uniform in appearance, particularly at abutments. Tiles should not have significant variations in texture, finish and colour. See Clause 9.1.13.

Cast stone elements

Cast stone should be reasonably uniform in both colour and texture.

Also note:

- efflorescence, fungal growth and colour variation may occur due to orientation, shading and pollution
- surface abrasions and chips should be repaired in accordance with the manufacturer's recommendations.

9.1.3 Internal walls and ceilings

Internal walls and ceilings shall be built to appropriate tolerances and have an acceptable finished appearance. Issues to be taken into account include:

- a) plastering and dry lining
- b) walls
- c) ceilings
- d) skirtings.

Plastering and dry lining

Plastered and dry lined surfaces should:

- not have board joints readily visible and be within a maximum $\pm 3\text{mm}$ deviation, measured using a 450mm straight edge with equal offsets
- be viewed from a distance of 2m in natural daylight with no artificial light shining on the surface. Wall lights and/or uplighters should be switched off.

Walls

Walls should:

- be reasonably uniform, although there may be minor textural differences around lights and other fittings
- have no visible gaps between fittings and the surface (eg around switch plates)
- have jointing tape fully covered and unobtrusive in the finished surface
- have flat walls and within a $\pm 3\text{mm}$ deviation measured using a 2m straight edge with equal offsets
- be a maximum of 8mm from plumb for walls up to 3m high. Taller walls should be a maximum of 8mm from plumb per storey and 12mm in total.

Figure 7: Straightness of internal walls in section

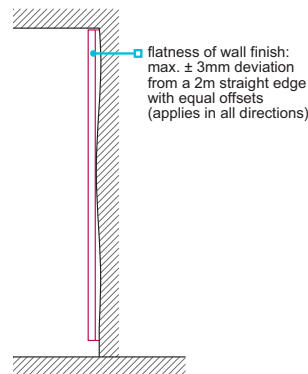
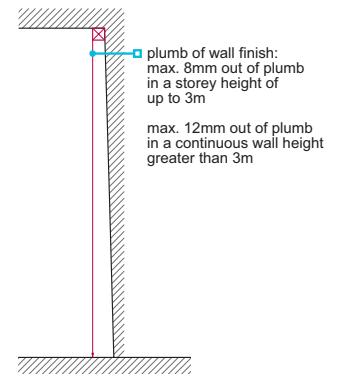

Figure 8: Plumb of internal walls



Ceilings

Ceilings should be:

- level within a 3mm deviation per 1m for ceilings up to 6m across (measured at the furthest points across the full width of the ceiling)
- a maximum of 20mm out of level for ceilings over 6m across
- flat within a $\pm 5\text{mm}$ deviation, measured using a 2m straight edge with equal offsets.

Figure 9: Level and flatness of ceilings

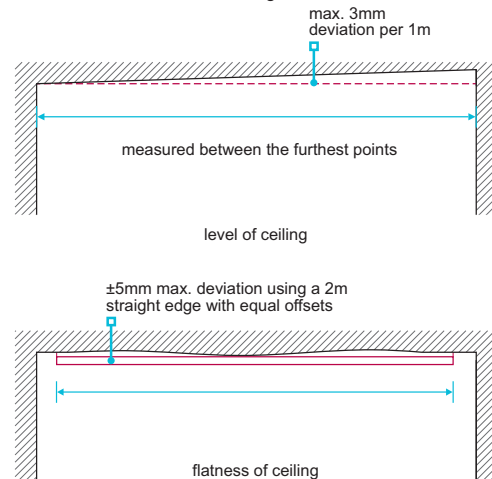

Setting out of corners, duct casings, access covers and any associated framing should be:

- square
- neat and tidy
- provided with an appropriate decorative finish.

Figure 10: Tolerances for external corner details

Tolerances for corner details

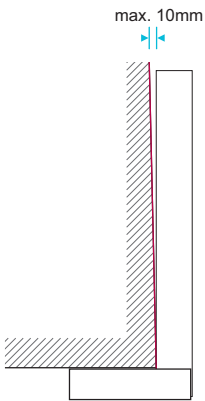

±10mm max. deviation from square in 500mm

Figure 11: Tolerances for internal corner details

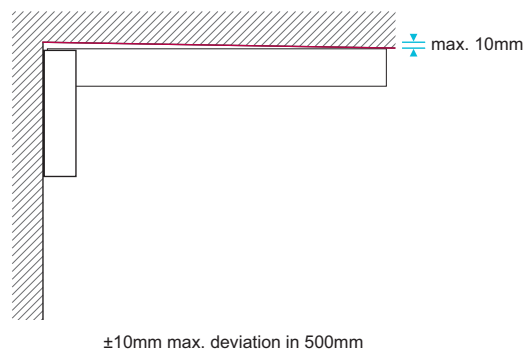

±10mm max. deviation in 500mm

Figure 12: Tolerances for boxings

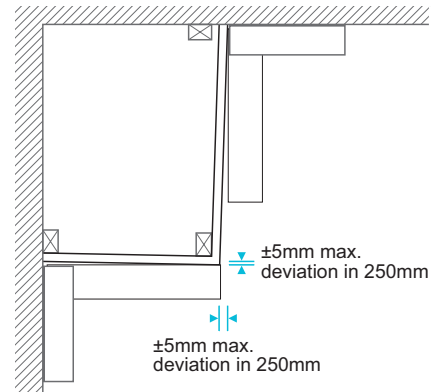

±5mm max. deviation in 250mm

±5mm max. deviation in 250mm

Also note:

- in plastered walls and ceilings, some tooling marks may be visible
- some cracking (up to 2mm wide) may occur at wall, floor and ceiling junctions, due to shrinkage and differential movement of materials
- small cracks may occur in wall finishes which pass across floors (eg in staircase walls)
- where stair strings abut a wall, a crack of up to 4mm may appear as a result of shrinkage of materials.

Skirtings

Where skirtings are installed:

- the gap between the floor finish (without coverings) and the bottom of the skirting should not exceed 5mm at the time of completion
- joints should present a continuous appearance when viewed from a distance of 2m in daylight (some initial shrinkage of the skirting may already be evident at completion of the property).

Also note:

- the gap between the floor finish and the skirting may increase due to normal drying out, shrinkage and/or deflection, particularly in timber floors
- gaps may appear at joints and corners due to shrinkage, and between the wall finish and skirting due to drying out, shrinkage and fixing position.

9.1.4 Doors and windows

Doors and windows shall be installed to appropriate tolerances, including openings in walls and external openings viewed from the inside.

Internal openings in walls should:

- be flat along the length of sills and window boards, with a maximum deviation of ±3mm in every 2m
- have level heads and sills, a maximum of 3mm from level for openings up to 1.5m, and 5mm where longer
- have plumb reveals, a maximum of 3mm from plumb for openings up to 1.5m high, and 5mm where higher
- be level within 3mm across the sill measured from the frame (tiled sills, in bathrooms, for example, may be intentionally laid sloping away from the window)
- be square with the window, with a maximum deviation of ±5mm for reveals up to 250mm deep.

Window frames should not be distorted in the opening, and a maximum from plumb of:

- 3mm when up to 1.5m in height
- 5mm when larger.

Figure 13: Tolerances for internal openings

Tolerances for internal openings

head and sill: max. 3mm out of level for openings up to 1.5m wide
max. 5mm out of level for openings over 1.5m wide

± 5mm max. deviation of square for reveals up to 250mm deep

max. 3mm out of level across reveal (measured from frame)*

reveals: max. 3mm out of plumb for openings up to 1.5m high
max. 5mm out of plumb for openings over 1.5m high

*tiled sills, in bathrooms, for example, may be intentionally laid sloping away from the window

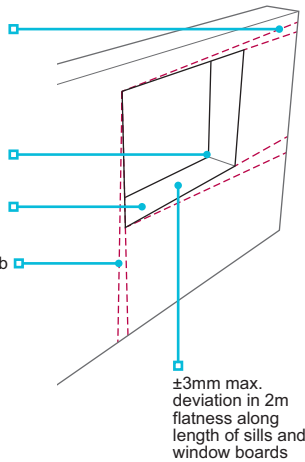

Figure 14: Tolerances for windows

Tolerances for windows

window distortion: max. 3mm out of plumb for windows less than 1.5m high

max. 5mm out of plumb for windows over 1.5m high

frames should not be distorted in the opening

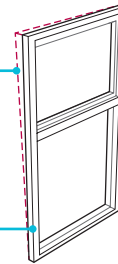

Internal doors

Internal doors and frames should always be installed in accordance with the manufacturer's recommendations, not be distorted in the opening, and:

- frames should be within 5mm of plumb over the height of the frame and not out of plumb in two directions
- the gap between the door and head or jamb should be a maximum of 4mm (for double doors, the gap at the meeting stiles should be within 4mm) and uniform
- distortion across doors should be limited to a maximum of 5mm in height, and 3mm in width
- the gap between the underside of the door and unfinished floor should be between 10mm and 22mm. The ventilation requirements for the building need to be taken into account when determining the gap beneath internal doors.

Figure 15: Tolerances for internal doors

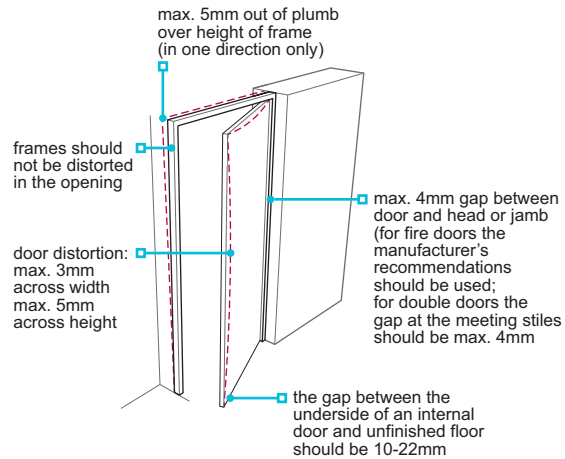

Fire doors

Fire doors should be installed in accordance with the manufacturer's recommendations. The tolerances in this clause are without prejudice to satisfactory performance for ventilation and fire resistance.

External doors

External doors and frames should be installed in accordance with the manufacturer's recommendations, not be distorted in the opening, and:

- frames should be within 5mm of plumb over the height of the frame and not be out of plumb in two directions
- distortion across the door should be limited to a maximum of 5mm in height and 3mm in width.

9.1.5 Floors

Floors shall be built to appropriate tolerances.

Floors should be:

- level within a 3mm deviation per 1m for floors up to 6m across (measured at the furthest points across the full width of the floor)
- a maximum of 20mm out of level for floors over 6m across
- flat within a ±5mm deviation, measured using a 2m straight edge with equal offsets.

Underfloor service ducts should be constructed so that the cover is level with the adjacent floor finish. The selection of floor finish should take into account that drying shrinkage of the floor may result in minor differences in level between the floor and duct cover, which may be more evident with some types of thin floor coverings.

9.1.6 Glazing

Glass shall be free from undue defects.

Glass should be checked in daylight, from within the room and from a minimum distance of 2m (3m for toughened, laminated or coated glass). The following are acceptable where they are not obtrusive or bunched:

- bubbles or blisters
- hairlines or blobs
- fine scratches not more than 25mm long
- minute particles.

The above does not apply to areas within 6mm of the edge of the pane, where minor scratching may occur.

9.1.7 Ceramic, concrete, terrazzo and similar tile finishes

Ceramic, concrete, terrazzo and similar tile finishes shall have an appropriate appearance.

For ceramic, concrete, terrazzo and similar tile finishes:

- joints should be straight and in alignment, unless the tiles are, by design, irregular in shape
- wall tile joints should be a minimum of 1.5mm for ceramic tiles, 2mm for smooth natural stone tiles and 6mm for textured tiles, unless otherwise specified by the manufacturer
- floor tile joints should be a minimum of 3mm and proportionally wider for larger tiles, unless otherwise specified by the manufacturer
- joints in floor tiles should generally not exceed the tile thickness, although wider joints up to 10mm may be necessary to accommodate dimensional irregularities in some tiles
- should limit the effect of dimensional irregularities, with joints suitably arranged to maintain a regular appearance
- the variation in surface level should be within ± 3 mm measured using a 2m straight edge with equal offsets
- the variation in surface level between adjacent tiles should be 1mm or less where the joint is up to 6mm wide, or 2mm or less where the joint is over 6mm wide.

9.1.8 Fitted furniture

Fitted furniture shall have an appropriate appearance.

Fitted furniture, including doors and drawers, should:

- be visually aligned (vertically, horizontally and in plan), and there should not be significant differences in level at the intersection of adjacent worktops
- operate as intended by the manufacturer
- have uniform gaps between adjacent doors and/or drawers where appropriate
- not have conspicuous abrasions or scratches on factory-finished components when viewed in daylight from a distance of 0.5m.

Also note:

- no dimensional tolerance has been set for gaps between adjacent doors and/or drawers or for their alignment, because some variation will be necessary to take account of adjustments as part of the fitting process
- no dimensional tolerance has been set for the abutment of adjacent worktops due to the variety of materials available and because minor variations, even with manufactured products, are inevitable and small differences in height may be unavoidable
- fitted furniture should be viewed from a distance of 0.5m
- conspicuous surface abrasions caused during installation should be removed in accordance with the manufacturer's recommendations, which may include filling, polishing out, respraying or painting as appropriate
- in rooms or areas where there is no daylight, scratches should be viewed in artificial light from fixed wall or ceiling outlets and not from portable equipment
- kitchen units should not delaminate, including those located near hobs and extractor fans.

9.1.9 Joint sealants

Joint sealants shall have a neat and tidy appearance.

Sealants should be tooled to:

- remove blisters and irregularities
- achieve a compact, smooth neat surface finish.

Also note:

- joints should be viewed from a distance of 2m, where possible, depending on the location (eg showers and baths may make this impossible).

9.1.10 Paint finishes

Painted and varnished surfaces shall be even in appearance and free from conspicuous runs and prominent brush marks.

Painted and varnished surfaces should:

- be reasonably smooth and free from nail holes, cracks and splits
- have joints filled
- be reasonably uniform in colour, texture and finish.

Also note:

- surfaces should be viewed in daylight from a distance of 2m and not by shining artificial light on the surface. Wall lights and/or uplighters should be switched off
- timber surfaces may show limited raised grain, and the colour and texture may also vary
- drying shrinkage of timber may cause cracking of the paint finish, particularly where joints occur in plaster and woodwork
- where painted surfaces are touched up, minor colour variations may occur
- external finishes will dull over time, depending on a number of factors such as exposure to sunlight, rain and pollutants
- resin can exude from knots, causing discoloration of paintwork, even though modern primers contain a compound to limit this
- site-decorated trim, such as architrave and skirting, may have a different finished appearance from factory-finished components, such as doors.

9.1.11 Sanitary ware

Baths, shower trays and basins shall be free from scratches, chips and other damage at the time of handover.

Sanitary fittings, such as baths, shower trays and basins, should not have conspicuous abrasions, scratches or chips when viewed in daylight from a distance of 0.5m.

Also note:

- in rooms or areas where there is no daylight, scratches should be viewed in artificial light from fixed wall or ceiling outlets and not from portable equipment.

9.1.12 Other surfaces and components

Other surfaces and finishes shall have an appropriate appearance.

Other surfaces and finishes, such as fascia boards, meter cabinets and radiators, should:

- be reasonably smooth and free from nail holes, cracks and splits
- have joints filled
- be reasonably uniform in colour, texture and finish.

9.1.13 Pitched roof coverings

Pitched roof coverings shall have an acceptable finished appearance.

Tiles and slates should:

- be reasonably uniform in texture, finish and colour
- be suitably mixed to avoid excessive colour banding.

Also note:

- some minor blemishes will occur on individual tiles and slates
- some minor variations will occur in the texture, finish and colour of individual tiles and slates
- efflorescence occurs naturally on some types of tile. It is not harmful and generally disappears over time. Tiles which have efflorescence when laid should be suitably mixed to avoid a patchy appearance.

9.1.14 Garages

Garages shall have an acceptable appearance.

Garage walls, floors and roofs should be built to appropriate tolerances.

Also note:

- cracks up to 2mm wide in unplastered blockwork walls may be evident due to thermal movement and shrinkage
- garage floors may be installed with falls for drainage or fire separation. Where garage floors have not been sealed, dusting may occur
- the effects of normal drying shrinkage of concrete floors could cause some small gaps around the perimeter at wall junctions.

9.1.15 External works

External works, including drives and paths, shall have appropriate finishes.

Drives and paths should be:

- within a maximum ± 10 mm deviation measured using a 2m straight edge with equal offsets; however, localised falls into gulleys and channels are acceptable
- designed and constructed to minimise the potential for standing water.

One hour after rain has stopped, areas of temporary standing water should not be deeper than 5mm or exceed 1m². Temporary standing water is not permitted adjacent to entrance doors.

Also note:

- displacement and variations in surface levels, including scuffing and pitting, may arise due to settlement, natural ground movement and traffic
- when checking flatness, the slope required for drainage on drives should be taken into account.

Drainage covers should:

- align with the adjacent ground or surface finish (for channels, the cover should be set below the adjacent ground)
- be positioned so that the difference in height between the cover and adjacent hard surfaces allows for future settlement.

9.1.16 Further information

Roof Tile Association Guidance - A developer and contractor guide to achieving the best visual effect with roof tiles manufactured from concrete and clay. Issue 1 August 2023.

Figure reference table

Figure reference table 9.1			
Fig No	Title/Description	Clause	Page
Figure 1	Straightness in plan for fair faced masonry	9.1.2	2
Figure 2	Straightness in section for fair faced masonry	9.1.2	2
Figure 3	Plumb in section for fair faced masonry	9.1.2	2
Figure 4	Straightness at reveals for fair faced masonry	9.1.2	2
Figure 5	Straightness of bed joints in fair faced masonry	9.1.2	2
Figure 6	Straightness in section for render	9.1.2	3
Figure 7	Straightness of internal walls in section	9.1.3	4
Figure 8	Plumb of internal walls	9.1.3	4
Figure 9	Level and flatness of ceilings	9.1.3	4
Figure 10	Tolerances for external corner details	9.1.3	5
Figure 11	Tolerances for internal corner details	9.1.3	5
Figure 12	Tolerances for boxings	9.1.3	5
Figure 13	Tolerances for internal openings	9.1.4	6
Figure 14	Tolerances for windows	9.1.4	6
Figure 15	Tolerances for internal doors	9.1.4	6



Chapter 9.2



Wall and ceiling finishes

This chapter gives guidance on meeting the Technical Requirements for internal wall and ceiling finishes.

9.2.1	Compliance	01
9.2.2	Provision of information	01
9.2.3	Plastering	01
9.2.4	Dry lining	03
9.2.5	Ceramic wall tiling	05

For figure reference tables in this chapter, please go to the end of the chapter

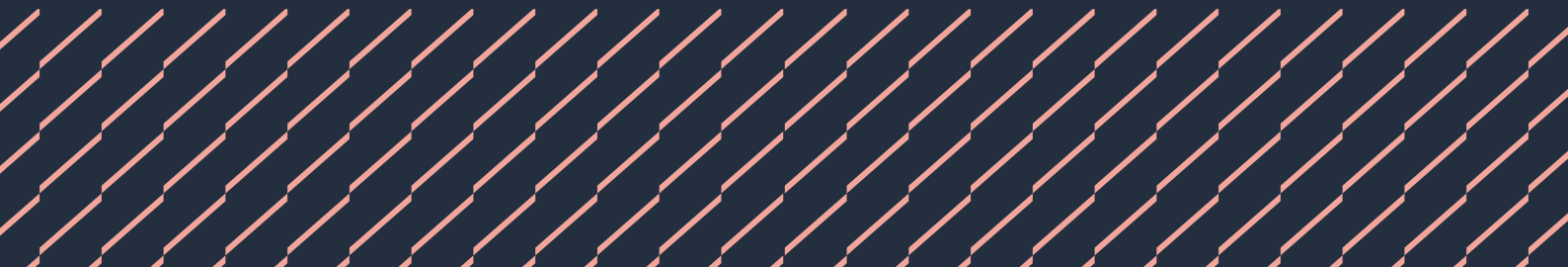

9.2.1 Compliance

Also see: Chapter 2.1

Wall and ceiling finishes shall comply with the Technical Requirements.

Wall and ceiling finishes that comply with the guidance in this chapter will generally be acceptable.

9.2.2 Provision of information

Designs and specifications shall be produced in a clearly understandable format, include all relevant information and be distributed to the appropriate personnel.

Designs and specifications should be issued to site supervisors, relevant specialist subcontractors and suppliers, and include the following information:

- schedule of finishes
- plaster thickness, mix and special requirements
- installation details of air and vapour control layers (AVCL) behind dry lining
- fixing specification
- extent and detail of tiled surfaces
- location of services adjacent to tiled surfaces.

9.2.3 Plastering

Also see: Chapter 8.1, BS 8000-0

Plastering shall provide an adequate substrate for the decorative finish.

The design, preparation and application of plasters should be in accordance with BS EN 13914-2 and BS 8481. Materials for plastering should be in accordance with BS 8481 and those listed in Table 1.

Where plaster is intended to contribute to fire resistance or sound insulation, overall performance should be in accordance with the Building Regulations.

Table 1: Materials for use in plastering

Plasters	BS EN 13279	'Gypsum binders and gypsum plasters. Definitions and requirements'.
	BS 5270-1	'Bonding agents for use with gypsum pasters and cement. Specification for polyvinyl acetate (PVAC) emulsion bonding agents for indoor use with gypsum building plasters'.
Metal laths and beads	BS EN 13658-1	'Metal lath and beads. Definitions, requirements and test methods. Internal plastering'.
	BS EN 13658-2	'Metal lath and beads - definitions, requirements and test methods. External rendering'.

The background should be:

- given an appropriate treatment before plastering, in accordance with BS 8481 and BS EN 13914-2
- suitably finished to provide an adequate key
- checked to ensure adequate and even suction
- sufficiently even to provide a reasonably flat plaster finish (excessive 'dubbing out' should be avoided).

Mixed background materials and associated differential movement can lead to cracks and should be avoided. Suitable precautions should be taken, eg using metal lathing.

Metal beads should be used to provide edge protection, and be fixed with zinc-plated fasteners, as recommended by the manufacturer.

Table 2: Recommended treatments for substrates

Surface	Treatment
High-density clay, concrete or calcium silicate bricks and blocks and dense concrete (including soffits)	Depending on suction and bond; may require use of a spatterdash pre-treatment or bond with polymer-modified cement mortar or metal lathing.
Lightweight clay block	The suction should be checked to ensure that it is similar to that of normal clay bricks. If not, special precautions may be necessary.
Mixed backgrounds, eg concrete with bricks/blocks	In accordance with BS EN 13914-2. May require either a carrier system or reinforced undercoat to reduce the effect of differential movement.
Lightweight concrete blocks	A polymer-modified spatterdash or bonding agent is recommended, depending on the plaster and the smoothness and suction of the blockwork.

Autoclaved aerated concrete blocks	Plastering should be conducted in accordance with the manufacturer's recommendations, accounting for the moisture content of the blocks. Depending on the absorption characteristics, the use of a suction reducing treatment may be required.
Normal clay brickwork	May require raked joints or the use of keyed bricks.
Concrete and calcium silicate brick - or blockwork	Dependant on the suction and bond, may require use of a spatterdash pre-treatment or metal lathing.
Plasterboard	Guidance is contained in BS 8000-8.

Where services are to be concealed by plaster, they should be:

- completed and tested before plastering
- protected against the adverse effects of chemical action or thermal movement.

At localised areas to avoid surface cracking; metal lathing or wire netting should be used where there is an insufficient depth of plaster.

The plaster mix should be:

- as specified, or as recommended by the plaster manufacturer for the particular location and use
- appropriate for the strength and surface characteristics of the background
- an appropriate quality for the intended finish
- checked to ensure undercoats and finishing coats are compatible
- applied by suitably trained operatives (specifically where plastic compound finishes are used)
- of a type that does not include Portland cement and gypsum plaster in the same mix.

When plastering:

- completed work, especially timber, chipboard and glazing, should be protected from damp and damage
- in cold weather, follow the guidance in Chapter 3.2 'Cold weather working' (plasterwork damaged by frost should be removed and replaced)
- dubbing out should be conducted well in advance of the application of the first coat
- surfaces should be dry, clean and free from laitance, grease, loose material or substances likely to prove harmful to the bond or the intended finished appearance of the plaster
- ensure plaster is thoroughly mixed but avoid prolonged mixing
- avoid mixing excessive quantities of plaster (plaster should not be retempered)
- the background surface of each coat should be fully set (the surface should not be overworked, and adequate time should be left between coats to allow strength and suction to develop)
- the number of coats should be sufficient to achieve a reasonably plane finish
- finished surfaces, reveals, soffits to openings, external angles, etc should be in accordance with Chapter 9.1 'A consistent approach to finishes'
- the plaster should be applied to a thickness, excluding dubbing out, in accordance with Table 3.

Table 3: Plaster thickness

	Surface to be plastered	Minimum number of coats	Thickness of plaster
Walls	Metal lathing	3	13mm (nominal from lathing)
	Brickwork	2	13mm maximum
	Blockwork	2	13mm maximum
	Plasterboard or concrete	1	Sufficient to provide a crack-free surface
Ceilings	Concrete	2	10mm maximum
	Plasterboard	1	Skimcoat

9.2.4 Dry lining

Also see: BS 8000-8, BS EN 520

Dry lining shall provide an adequate substrate for the decorative finish. Issues to be taken into account include:

- | | |
|----------------------------------|--------------------------|
| a) installation | c) detailing and support |
| b) air and vapour control (AVCL) | d) fixing. |

Installation

Dry lining should:

- not be started until the building is substantially weatherproofed
- not be started until structural timber components are at a moisture content of 20% or less
- be programmed so that finishes are applied as soon as possible after completion
- provide performance in accordance with Building Regulations where it contributes to fire resistance
- ensure that gap sealing is specified where necessary to prevent draughts
- be appropriate for the application, eg be moisture resistant to walls and ceilings in bathrooms and ensuites.

Table 4: Standards relevant to dry lining

BS EN 520	'Gypsum plasterboards. Definitions, requirements and test methods'.
BS 8000-8	'Workmanship on construction sites. Design and installation of dry lining systems – Code of practice'.

Air and vapour control (AVCL)

Air and vapour control layers should be used to reduce the risk of interstitial condensation and enhance air tightness, and be installed in accordance with:

- Chapter 6.2 'External timber framed walls'
- Chapter 6.10 'Light steel framing'
- Chapter 7.1 'Flat roofs and balconies'
- Chapter 7.2 'Pitched roofs'.

Detailing and support

Support should be provided to plasterboard walls and ceilings in accordance with Tables 5 and 6. Where walls are to receive ceramic tiling, additional support may be required, see Table 10.

Table 5: Frequency of support for plasterboard to walls

Board thickness (mm)	Maximum timber support centres (mm) ⁽¹⁾
9.5	450
12.5, 15 & 19	600

Table 6: Frequency of support for plasterboard to ceilings

Board thickness (mm)	Maximum timber support centres (mm)	Intermediate noggings required ⁽¹⁾	Perimeter noggings required ⁽¹⁾
9.5	400	No	Yes
	450	Yes	Yes
12.5 & 15	400	No	Yes
	450	No	Yes
	600	Yes	Yes
19	600	No	No

Notes:

1. Alternatively, the spacing of studs and joists, the requirements for intermediate and perimeter noggings, and any additional support battens should be in accordance with the plasterboard or system manufacturer's installation instructions or fire test evidence, or applicable industry guidance documents.

When fixing boards:

- damaged boards should not be used
- they should be fixed face side out, appropriate for plastering or directly applied finishes
- cut edges should finish over a support or nogging (though are permitted, where necessary, at perimeters)
- there should be adequate support for light points, socket outlets and other service installations
- openings for services and electrical outlets should be accurately cut (gaps in the air and vapour control layers should be taped and sealed)
- ceiling boards should be staggered to minimise any risk of cracking
- where metal resilient bars are installed to ceilings, additional resilient bar perimeter noggings should be installed in accordance with the manufacturer's installation instructions and/or supporting fire test evidence.

Joints between boards should be neatly formed, flush, and suitably finished:

- with scrim tape or paper tape, where boards are to be plastered
- with tape, and filled, where boards are not to be plastered (tapered edge boards should be used for directly applied finishes), or
- as recommended by the manufacturer.

Where double layers of plasterboard are used, they should:

- be positioned so joints are staggered between layers
- have the first layer fully fixed and have all cut edges supported
- have the second layer supported on all edges with noggings provided to suit.

Figure 1: Nogging and board arrangements where two layers of plasterboard are installed to ceilings

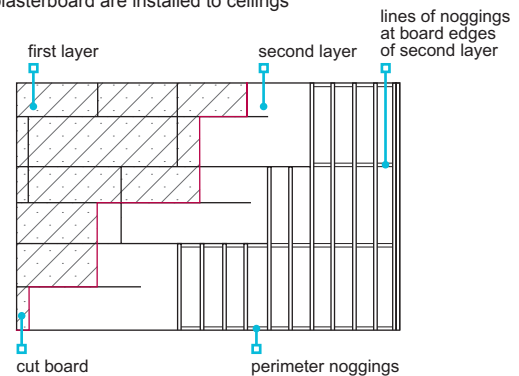

Dry lining should be:

- completely taped and filled at board joints and at the abutments to ceilings and internal walls
- finished to an appropriate standard and in accordance with Chapter 9.1 'A consistent approach to finishes'.

Fixing

Plasterboard should be fixed to:

- timber using dry wall screws
- metal using dry wall screws, or
- masonry using adhesive dabs.

Where insulated dry lining is used, nailable plugs should be specified in accordance with the manufacturer's recommendations, and at a minimum of two per board.

Screws should not project above the board surface and should be:

- 10mm minimum from paper-bound edges
- 13mm minimum from cut ends of boards
- 6mm minimum from edges of timber members.

Table 7: Acceptable fixing centres

Fixing	Location and spacing	Coating
Screw	Ceilings: approximately 230mm centres (eight per two linear metres) within the field of the plasterboard, and 150mm at plasterboard ends and ceiling perimeters. Walls: approximately 300mm centres (five per linear metre), and 200mm on external corners and around openings.	Zinc electroplated or black phosphate (or to the board manufacturer's recommendations).

Table 8: Acceptable fixing lengths

Board thickness (mm)	Screw length (mm) into timber	Screw length (mm) into steel
9.5	35	25
12.5	38	25
15	40	25
2 x 12.5	50	35
2 x 15	60	40
1 x 12.5 & 1 x 19	57	42

Where walls or ceilings require fire resistance, fixings should be installed in accordance with the plasterboard or system manufacturer's fire test evidence.

Where dry lining is fixed with adhesive dabs, it should be:

- securely fixed and filled at external and internal corners, including door and window openings
- filled with jointing compound where required, at gaps around service points, electric sockets, light switches, etc
- installed with a continuous ribbon of adhesive to the perimeter of external walls, and around openings and services, to prevent air infiltration.

Adhesive dabs should be at 300mm centres measured vertically, each dab should be 50 mm to 75 mm wide and approximately 250 mm long and in accordance with Table 9.

Table 9: Dabs according to board dimensions

Thickness of wall board (mm)	Width of wall board (mm)	Vertical rows of dabs per board
9.5	1200	4
12.5	1200	3
15.0	1200	3

Dry lining to receive ceramic wall tiling should be supported in accordance with Table 10 or the guidance given in BS 8000-8.

Table 10: Board fixing guidance for walls to receive ceramic tiles

Description	Board thickness (mm)	Support centres (mm)	Additional support	Maximum height (mm)	Comments
Timber frame (including stud walling)	12.5, 15	400-450	No	3 600	
		600	Timber noggings 600mm centres (measured vertically)	3 600	
Timber battens	12.5, 15	400	Battens at head, base and intermediate positions not exceeding 1200mm centres	3 600	
Direct bond	9.5	400 dabs of adhesive in rows	Horizontal dabs at 1/3 centers in height	3 600	Complete at least 10 days before tiling
Independent steel stud lining, 48mm or 60mm	2 x 12.5	400	Mid-point support	3 000	
48mm metal stud partitions	15 2 x 12.5 each side, or 2 x 15 each side	400		2 700	
		400		3 600	
70mm metal stud partitions	15 2 x 12.5 each side, or 2 x 15 each side	400		3 600	
		400		3 600	
146mm metal stud partitions	2 x 15 each side	600	Additional stud at 300mm up to tile height	3 600	

Also see: Clause 9.2.4, Tile Association Guides 'Internal Ceramic Tiling to Sheet and Board Substrates', 'Tiling in Wet Rooms and Showers', 'The fixing of ceramic wall tiles to gypsum plaster surfaces on masonry backgrounds'

9.2.5 Ceramic wall tiling

Ceramic wall tiling shall provide a surface adequate for its location and intended use (including appearance and durability).

Ceramic tiling and backing surfaces to walls should be in accordance with BS 5385.

Where a fixed shower or showerhead fixing is provided over a bath, at a height that will permit persons to stand under it:

- a screen or other suitable means of containing the water should be provided
- surfaces which will become regularly wetted should be tiled or have an appropriate alternative water-resistant finish.

Backing surfaces for tiling should:

- be in accordance with Table 10 & 11, BS 8000-8 and BS 5385
- be strong enough to support the weight of the adhesive and tiling (where separate coats are used, they should be well bonded)
- where dry lining is fixed with dabs of adhesive this should be completed at least 10 days before wall tiling takes place
- provide an adequate mechanical key
- be sufficiently even to achieve an even and plane tiled surface
- provide adequate and consistent suction
- be rigid and stable to avoid differential movement; where this may occur, precautions should be taken, eg metal lathing or wire netting fixed across junctions
- be dry, clean and free from laitance, grease, loose material or any substance likely to affect the bond or finish
- be reasonably even (ie, not have gaps greater than 3mm for thin bed adhesives or 6mm for thick bed adhesives, when using a 2m straight edge).

Guidance on suitable backing surfaces for tiling and the use of proprietary intermediate waterproofing layers (tanking systems) can be found in BS 5385 Parts 1 and 4, and Table 11 below.

Table 11: Suitable backing surfaces for tiling

Conditions	Example location	Acceptable backing surface	Intermediate waterproofing layer (tanking system) required	Additional requirements
Installations in normal internal conditions (BS 5385-1)	Rooms which do not contain a shower or bath, eg bedroom, living room etc	Cement rendering, masonry, gypsum plaster, plasterboard etc	No	None
Installations not immersed but subject to occasional wetting (BS 5385-4 Section 7.2.3)	Domestic (not power) showers, baths	Water-resistant materials (ie, sand and cement mortar or rendering, concrete etc)	No	Tiles solidly bedded on water-resistant adhesive Water-resistant grout if tanking is not used
		Proprietary tile backing boards (not gypsum-based)	Yes (Unless the board manufacturer can demonstrate the board is watertight)	
		Moisture-resistant plasterboard & gypsum-based tile backing boards	Yes	
Installations not immersed but subject to frequent wetting (BS 5385-4 Section 7.2.4)	Wet rooms, domestic power showers, communal showers, swimming pool halls	Water-resistant materials (ie, sand and cement mortar or rendering, concrete etc)	Yes	Tiles solidly bedded on water-resistant adhesive
		Proprietary tile backing boards (not gypsum-based)		
Installations in high humidity areas (BS 5385-4 Section 7.2.2)	Areas with constant high humidity (eg saunas and steam rooms)	Water-resistant materials (ie, cement mortar, screed or rendering)	No	Tiles solidly bedded on water-resistant adhesive Water-resistant grout
		Proprietary tile backing boards (not gypsum-based)	Yes (Unless the board manufacturer can demonstrate the board is watertight)	

Where the backing surface contains soluble salts, and where cement mortar is used as an adhesive, precautions should be taken, such as the use of mortar with cements which resist sulfates.

Gypsum-based materials should not be used where repeated or persistent heating occurs, eg on flues or near heat sources.

Backgrounds may be improved by:

- raking out masonry joints
- hacking and scratching
- applying a bonding agent (particularly on very smooth and dense surfaces).

Tiles should be appropriate for their location and intended use. When specifying tiles, consideration should be given to:

- surface finish
- size and thickness
- colour
- edge shape
- fittings (coves, skirtings, etc)
- accessories (soap tray, paper holder, hooks, etc).

Tiles should be:

- fixed in accordance with manufacturers' instructions
- suitable for the location, intended use and background; their weight on lightweight plaster should not exceed 20kg/m²
- fixed according to the background, using cement mortar or proprietary adhesive
- solidly bedded where their surface area is greater than 0.1m² or where their weight exceeds 70% of the background's capacity to carry the weight.

Table 12: Standards for tiling

BS EN 14411	'Ceramic tiles. Definition, classification, characteristics, assessment and verification of constancy of performance and marking'.
BS EN 12004	'Adhesives for ceramic tiles. Test methods'.
BS EN 13888	'Grouts for tiles. Requirements, evaluation of conformity, classification and labelling'.
BS 5385 - 1	'Wall and floor tiling. Design and installation of ceramic, natural stone and mosaic wall tiling in normal internal conditions. Code of practice'.
BS 5385 - 4	'Design and installation of ceramic and mosaic tiling in specific conditions – Code of practice'.

When tiling:

- courses should be straight and even to form a plane and regular surface, especially around fittings and fixtures
- there should be no cut or unfinished tiles at exposed edges or external corners
- joints should be even and cut neatly
- spacing should be sufficient to allow for expansion
- up to sanitary fittings and fixings, the sealing method should be in accordance with the design and account for movement
- proprietary water-resistant grouting should be used in accordance with the manufacturer's recommendations.

Appropriately designed movement joints should be:

- built into tiling at centres at a maximum of 4.5m, vertically and horizontally
- provided at vertical corners in large tiled areas
- located at junctions where there are variations in surfaces or backgrounds
- provided where the tiles abut other materials
- 1-2mm where tiles are without spacer lugs.

Grouting should be:

- as specified in the design, including mix and colour
- cement-based epoxy resin or a proprietary product.

Figure reference table

Figure reference table 9.2			
Fig No	Title/Description	Clause	Page
Figure 1	Nogging and board arrangements where two layers of plasterboard are installed to ceilings	9.2.4	4



Chapter 9.3



Floor finishes

This chapter gives guidance on meeting the Technical Requirements for floor finishes, including:

- integral insulation
- screeds
- ceramic, concrete and similar tiles
- flexible sheet and tiles
- woodblock
- asphalt.

9.3.1	Compliance	01
9.3.2	Provision of information	01
9.3.3	Insulation	01
9.3.4	Screed	01
9.3.5	Ceramic, concrete, terrazzo and similar tile finishes	03
9.3.6	Wood finishes	05
9.3.7	Flexible sheet and flexible tile finishes	07
9.3.8	Asphalt finishes	07
9.3.9	Staircase finishes	08

For figure reference tables in this chapter, please go to the end of the chapter



9.3.1 Compliance

Also see: Chapters 2.1, 5.1, 5.2, 6.4 and 8.1

Floor finishes shall comply with the Technical Requirements.

Floor finishes which comply with the guidance in this chapter will generally be acceptable (structural floors should be in accordance with the relevant Standards chapter).

9.3.2 Provision of information

Designs and specifications shall be produced in a clearly understandable format, include all relevant information and be distributed to the appropriate personnel.

Designs and specifications should be issued to site supervisors, relevant specialist subcontractors and suppliers, and include the following information:

- schedule of finishes
- screed thickness and mix
- details of sound insulating floors
- extent and detail of tiled surfaces
- location of services adjacent to tiled surfaces
- details of staircase finishes.

9.3.3 Insulation

Thermal and acoustic insulation shall provide appropriate performance, and be suitable for the intended location and use.

Materials and constructions which are in accordance with Building Regulations are generally acceptable.

Suitable sound insulation materials include:

- flexible material
- mineral fibre quilt insulation
- board material for use under screeds (eg EPS SD grade expanded polystyrene)
- proprietary products which have been assessed in accordance with Technical Requirement R3.

Table 1: Thermal insulation materials

Material	Standard	Grade or description
EPS (expanded polystyrene)	BS EN 13163	70
PUR (rigid polyurethane)	BS 4841	For use under screeds
PIR (rigid polyisocyanurate)		
Fibre building board	BS EN 622	Insulating board (softboard)
Proprietary material	Technical Requirement R3	

9.3.4 Screed

Also see: Chapters 3.2 and 8.1

Non-structural floor screeds shall be adequate for the location and intended use, and provide a suitable background for floor finishes. Issues to be taken into account include:

- a) installation
- b) non-structural screed thickness
- c) screed over insulation.

Installation

Before screeding, background surfaces should be:

- clean and free of debris (eg dust and gypsum removed); concrete should be wetted and brushed
- suitably prepared to provide an adequate mechanical key, where bonded screeds are required, cement grouting or a bonding agent should be specified to provide adequate adhesion.

Damp proofing should be completed before screeding starts.

Screeding should not take place in weather conditions which could adversely affect the finished construction, and:

- should be scheduled to allow suitable drying time before following trades
- in hot or dry weather, precautions should be taken to prevent the screed surface drying out too quickly
- in cold weather, screeds should not be installed (screed damaged by cold should be removed and replaced).

Non-structural screed should be:

- installed to the specified thickness and provide an even surface, suitable for the intended finish in accordance with the relevant British Standards and the floor finish manufacturer's recommendations
- of a suitable sand cement mix (generally between 1:3 and 1:4½ cement:sand). Where deeper than 40mm, concrete may be used
- (where the floor is to include a monolithic slab) installed within three hours of the concrete sub-floor being poured
- mixed using only proprietary additives that have been assessed in accordance with Technical Requirement R3
- thoroughly compacted, where required by the design, using either a heavy tamper, mechanical compactor or vibrator.

Proprietary non-structural screeds should be installed in accordance with the manufacturer's recommendations.

Surface sealers or hardeners should only be used in accordance with the manufacturer's instructions.

Where services are bedded in the screed:

- there should be a minimum 25mm of cover over the highest point of pipes and insulation
- provision should be made for the thermal movement of water pipes
- pipes should be protected against chemical attack (eg by using purpose-made sleeves or ducts).

Non-structural screed over underfloor heating should:

- be sub-divided into bays not exceeding 40m², with a maximum length of 8m, or installed per room
- have expansion joints which are consistent with those in the substructure
- have expansion joints between independently controlled heating zones.

Where proprietary non-structural screeds are used in conjunction with underfloor heating, manufacturer's recommendations should be followed in relation to installation and the provision of expansion joints.

Where tiles are applied to proprietary screeds, movement joints should be provided in accordance with Clause 9.3.5.

Where concrete floor slabs are to serve directly as a wearing surface without an additional topping, they should be in accordance with BS 8204-2 and power floated.

Completed floor finishes should be protected against damage from traffic.

Standards relevant to screeding include:

BS 8204 Parts 1 to 7	'Screeds, bases and in-situ floorings'
BS 8201	'Code of practice for installation of flooring of wood and wood-based panels'
BS 8203	'Installation of resilient floor coverings. Code of practice'
BS EN 1264 Parts 1 to 5	'Water based surface embedded heating and cooling systems'

Non-structural screed thickness

Thickness of cement and sand screeds should be in accordance with with Table 2.

Table 2: Thickness of non-structural screed

Method of laying	Minimum thickness at any point (mm)
Installed monolithically with base	12
Installed on, and bonded to, a set and hardened base	25
Installed on a separating membrane (eg 1000g polyethylene)	50
Installed on resilient slabs or quilts (screed reinforced with wire mesh)	65
Above services, reinforcement or insulation to services	25

For concrete ground-bearing floors, a maximum 20mm monolithic screed may be acceptable as part of the required thickness.

Screed over insulation

Where screed is to be installed over insulation, the screed should be reinforced, and the insulation should:

- provide adequate compressive strength to support wet construction screeds and floor loads
- be tightly butted and, where required, turned up at perimeters to prevent thermal bridging
- be separated from the screed by a membrane (the membrane should be compatible with the insulation, and have joints lapped and taped, and be turned up at the perimeter).

Sound insulating floating floors should be in accordance with building regulations.

Figure 1: Screed over insulation

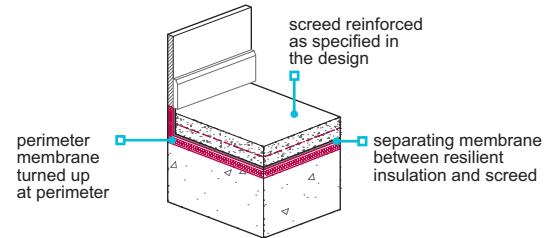

9.3.5 Ceramic, concrete, terrazzo and similar tile finishes

Tile flooring shall provide a suitable wearing surface for the location and intended use.

Before tiling is started:

- ensure that the substrate is sufficiently dry (generally, six weeks for concrete bases and three weeks for screed is adequate)
- ensure the substrate is reasonably true and flat ($\pm 3\text{mm}$ using a 2m straight edge)

Where a Calcium sulphate (Anhydrite) screed is used:

- ensure that the substrate is sufficiently dry. Calcium sulphate screeds generally should be allowed to dry at a rate of 1 day per mm of screed thickness for screeds up to 40mm thickness, and 2 days per mm for any additional thickness over 40mm, however it should be ensured that the moisture content does not exceed 75% RH before tiling begins
- the weak layer of laitance which forms on the surface of the screed should be removed

When installing tiles to floors:

- they should be bedded on a solid bed of mortar or proprietary adhesive, of a thickness appropriate for the material
- the manufacturer's recommendations should be followed where proprietary adhesives are used
- they should be arranged to minimise cutting and to provide joints which are straight, neat, and of even width

Where tiles are to be fixed to a wood-based substrate:

- the floor should be designed to take the additional loads of tiles, and any other materials (eg overlays)
- they should be suitable for laying over a timber base

- ensure that falls, where required, are in accordance with the design
- differences in level should be dubbed out
- the surface should be clean and free from laitance, dirt, dust, grease and materials incompatible with the adhesive.

- the screed should be sealed with an appropriate primer in accordance with the manufacturer's recommendations
- where it is likely to be exposed to occasional wetting (ie, where a bath or shower is present), it should be protected by the application of an additional intermediate waterproofing layer (tanking system) prior to the installation of tiling.

- accessories, such as covings and skirtings, should match the tile pattern, and be fixed so that joints are aligned with those in the floor
- they should be installed with minimum 3mm joints, unless otherwise specified by the manufacturer.

- they should be bedded with deformable (flexible) tile adhesive, eg C2S1, and grouted in accordance with the manufacturer's recommendations.

Guidance on suitable backing surfaces for tiling on wood-based floors can be found in Table 3 below. For further guidance see BS 5385 Parts 3 and 4.

Table 3: Suitable backing surfaces for tiling on wood-based floors

Conditions	Example location	Acceptable substructure	Intermediate waterproofing layer (tanking system) required	Additional requirements
Installations in normal internal conditions (BS 5385-1)	Rooms which do not contain a shower or bath (eg kitchen/utility room, cloakrooms/WC)	Moisture-resistant wood-based floor decking: Plywood ⁽¹⁾ to BS EN 636-3S or P5 Chipboard ⁽²⁾ overlaid with 10mm plywood to BS EN 636-3	No	Tiles solidly bedded on flexible tile adhesive (eg C2S1) Water-resistant grout
Installations not immersed but subject to occasional wetting (BS 5385-4 Section 7.2.3)	Domestic bathrooms	Moisture-resistant wood-based floor decking (ie, BS EN 636-3S plywood ⁽¹⁾ or P5 chipboard ⁽²⁾), overlaid with minimum 10mm thick proprietary tile backing board (not gypsum-based), or alternative wood-based board where approved for use as a tiling substrate by the manufacturer	No	Tiles solidly bedded on flexible tile adhesive (eg C2S1) Water-resistant grout
		Proprietary floor decking board (not wood or gypsum-based) of an appropriate type and thickness used as the floor decking ⁽³⁾		
Installations not immersed but subject to frequent wetting (BS 5385-4 Section 7.2.4)	Wet rooms & communal showers	Moisture-resistant wood-based floor decking (as above), overlaid with minimum 10mm thick proprietary tile backing board (not gypsum-based)	Yes	Tiles solidly bedded on flexible tile adhesive (eg C2S1) Water-resistant grout
		Proprietary tile backing board (not gypsum-based) of an appropriate thickness suitable for use as the floor decking ⁽³⁾		
Installations in high humidity areas (BS 5385-4 Section 7.2.2)	Areas with constant high humidity (eg saunas and steam rooms)	Moisture-resistant wood-based floor decking (as above), overlaid with minimum 10mm thick proprietary tile backing board (not gypsum-based)	No	Tiles solidly bedded on flexible tile adhesive (eg C2S1) Water-resistant grout
		Proprietary tile backing board (not gypsum-based) of an appropriate type and thickness suitable for use as the floor decking ⁽³⁾		

Notes

- (1) Plywood to BS EN 636-3S (minimum 15mm for joists at 400/450mm centres and minimum 18mm for joists at 600mm centres) screwed to the joists at 300mm centres with all square edges supported on joists or noggings (plywood should be installed with a 1.5-2mm movement gap between boards and at abutments, and be acclimatised to the room conditions and sealed on the underside and square edges, before laying, with a suitable sealer such as polyurethane varnish.
- (2) Moisture-resistant chipboard P5 grade overlaid with minimum 10mm plywood to BS EN 636-3, acclimatised, sealed and fixed as previously indicated, or proprietary separating/decoupling layers, tile backer boards or tile bedding reinforcement sheets used in accordance with the manufacturer's recommendations.
- (3) Proprietary tile backing boards should be assessed in accordance with NHBC Technical Requirement R3.

Movement joints should be:

- provided around the floor perimeter and at rigid upstands, where tiled areas are wider than 2m
- used to separate bays at 8-10m centers. Where underfloor heating is proposed the floor area should be divided up by intermediate movement joints into bays of size not greater than 40m² with an edge length not greater than 8m
- a minimum of 3mm wide unless otherwise specified by the manufacturer
- provided on suspended floors where tiles continue over changes in the sub floor construction and flexing is likely to occur eg over a supporting wall where end bearings of beam and block joists may be found.

Grout should be:

- cement-based epoxy resin or a proprietary product
- water resistant, where tiles may become saturated.

Standards relevant to floor finishes include:

BS 8204-3	'Screeds, bases and in-situ floorings. Polymer modified cementitious levelling screeds and wearing screeds. Code of practice'
BS EN 13748-1	'Terrazzo tiles for internal use'
BS EN 14411	'Ceramic tiles. Definition, classification, characteristics, assessment and verification of constancy of performance and marking'
BS 5385-3	'Wall and floor tiling. Design and installation of internal and external ceramic and mosaic floor tiling in normal conditions. Code of practice'
BS 5385-4	'Wall and floor tiling. Design and installation of ceramic and mosaic tiling in specific conditions. Code of practice'
BS EN 13888:2009	'Grout for tiles. Requirements, evaluation of conformity, classification and designation'

9.3.6 Wood finishes

Also see: BS 5250 and BRE Report 'Thermal insulation: avoiding risks'

Wood and wood-based flooring shall provide a suitable wearing surface for the location and intended use. Issues to be taken into account include:

- | | |
|--------------------------------|---------------------------------|
| a) thermal insulation and DPMs | d) directly applied finishes |
| b) sound insulation | e) indirectly applied finishes. |
| c) condition of the substrate | |

Wood and wood-based flooring should be installed ensuring that:

- services beneath the floor finish are tested before the floor is installed
- underfloor heating is kept on before and during the floor laying
- wood finishes are conditioned to the appropriate moisture content
- where required, DPMs are incorporated in accordance with manufacturer's recommendations and the design.

Standards relevant to wood floor finishes include:

BS 8201	'Code of practice for installation of flooring of wood and wood-based panels'
BS 1187	'Specification for wood blocks for floors'
BS 4050 Parts 1 and 2	'Specification for mosaic parquet panels'
BS 1202 Parts 1 to 3	'Specification for nails'
BS 1297	'Specification for tongued and grooved softwood flooring'

Thermal insulation and DPMs

Methods of providing insulation include:

- insulation positioned above in-situ concrete slab (DPM required)
- insulation positioned above dry, precast system (In certain circumstances a DPM may be omitted see Chapter 5.2 'Suspended ground floors' for further information).

Figure 2: Location of DPM and insulation on ground-bearing slab

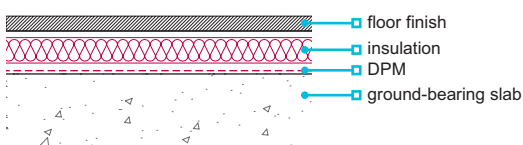
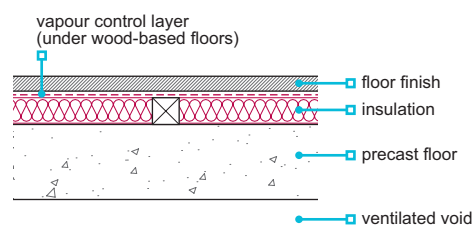

Figure 3: Location of DPM, VCL and insulation on precast floor



Proprietary insulated flooring should be in accordance with:

- Technical Requirement R3
- manufacturer's recommendations on vapour control layers and DPMs.

Sound insulation

Floating floor finishes should be designed and constructed to:

- isolate the floor finish from the supporting floor and walls
- avoid excessive movement or squeaking
- avoid the use of fixings which penetrate the insulation layer
- ensure there are no airpaths, especially at the perimeter.

Where flooring is to be installed on a resilient material on a separating floor, edges should be isolated from walls and skirtings by a resilient layer.

Where a floor relies on a soft floor covering to provide the minimum standard of sound insulation, the covering should be fixed permanently in position.

Condition of the substrate

Screeds or concrete to receive wood flooring should be dry. The floor should:

- be tested and the moisture content suitable, in accordance with BS 8201
- be allowed to cure for a sufficient period of time (generally two months for 50mm screed, and six months for concrete slabs), or
- have a DPM and/or air and vapour control layer incorporated in the floor construction to protect the wood finishes (moisture should not be trapped between the layers).

Screeds or concrete to receive wood flooring should:

- be free from high spots, nibs and major irregularities
- have differences in level dubbed out.

Directly applied finishes (wood blocks, parquet, wood mosaic, etc)

Directly applied finishes should be installed:

- in accordance with the manufacturer's recommendations
- using the correct adhesives, eg bitumen rubber emulsion in accordance with BS 8201 or proprietary adhesives assessed in accordance with Technical Requirement R3
- using evenly spread adhesives
- according to the specified pattern, and leaving gaps around the perimeter for movement.

Screeds or concrete surfaces should be treated with a suitable primer in accordance with the adhesive manufacturer's recommendations.

Indirectly applied finishes (softwood boarding, wood-based panel products)

Indirectly applied finishes should be installed with:

- air and vapour control layers where required
- preservative treated battens, in accordance with Chapter 3.3 'Timber preservation (natural solid timber)'
- provision made to support heavy items, such as storage heaters and boilers
- battens fixed to prevent excessive movement
- battens spaced in accordance with Table 4.

Table 4: Spacing of battens for indirectly applied floor finishes

	Thickness of finish (mm)	Maximum batten centres (mm)
Chipboard (type P5)	18	450
	22	600
Plywood	15	450
	18/19	600
Oriented strand board (type OSB3)	15	450
	18/19	600
Other types of floor	In accordance with the manufacturer's instructions	

Chipboard and oriented strand board should be fixed to battens:

- with flat-head ring shank nails or screws
- with fixings 2.5 x the thickness of the board
- at 200mm-300mm centres at perimeters
- at 400mm centres on intermediate supports.

Plywood should be fixed to battens:

- with 10 gauge nails or screws
- a minimum of 10mm from the edges of boards
- at 150mm centres at perimeters
- at 300mm centres on intermediate supports.

9.3.7 Flexible sheet and flexible tile finishes

Also see: BS 5250 and BRE Report
'Thermal insulation: avoiding risks'

Flexible sheet and flexible tile finishes shall provide a suitable wearing surface for the location and intended use.

Flexible sheet and flexible tile finishes should be:

- installed in accordance with the manufacturer's recommendations, and generally be fully bonded
- installed on a backing surface which is even and without high spots or cracks; where necessary, using a fabricated underlay of a type and thickness recommended by the flooring manufacturer or in accordance with Table 5
- reasonably level and smooth, particularly at doorways and junctions
- fitted with skirtings, coves, coverstrips and other preformed components, where required, and in accordance with the manufacturer's recommendations.

Table 5: Acceptable types of fabricated underlay for boarded surfaces

Type of underlay	Minimum thickness (mm)
Hardboard	4.8
Plywood	5.5

Plywood or hardboard fabricated underlays should be fixed:

- with ring shank nails or screws finished flush with surface
- with fixings 2.5x the thickness of the underlay (but no longer than the combined thickness of the underlay and deck)
- with nails/screws at least 10mm from the edge of the panel
- around perimeters, at 100mm centres
- across the sheets, at 150mm centres.

Flexible sheet flooring materials should:

- be stored in a clean and ventilated place
- not be stored in cold conditions, unless permitted by the manufacturer
- not be exposed to temperatures less than 18°C for a period of 24 hours before, or during, laying.

The substrate should be sufficiently dry to prevent adverse effects on the flooring, and where:

- there is a risk of trapping moisture or interstitial condensation, permeable finishes should be used
- flexible sheet or tile flooring is installed on ground bearing concrete floors, a DPM should be incorporated to prevent rising moisture adversely affecting floor finishes.

When installing flexible sheet or tile flooring:

- ensure underfloor services are not damaged
- it should be cut so that it fits neatly around fittings, pipes, etc
- adhesives should be spread evenly and left for the correct period of time to ensure full bonding
- the surface should be pressed down firmly, loaded or rolled as necessary to prevent curling, lifting or bubbling
- surplus adhesive should be removed
- welded joints should be provided in accordance with the manufacturer's recommendations
- adjustment after initial contraction or expansion should be made where necessary.

Standards relevant to flexible sheet and tile finishes include:

BS EN ISO 10581	'Resilient floor coverings. Homogeneous poly(vinyl chloride) floor covering. Specifications'
BS EN ISO 10595	'Resilient floor coverings. Semi-flexible/vinyl composition (VCT) poly(vinyl chloride) floor tiles. Specification'
BS EN 650	'Resilient floor coverings. Polyvinyl chloride floor coverings on jute backing or on polyester felt backing or on a polyester felt with a polyvinyl chloride backing. Specification'
BS EN 651	'Resilient floor coverings. Polyvinyl chloride floor coverings with foam layer. Specification'
BS EN 12104	'Resilient floor coverings. Cork floor tiles. Specification'
BS 8203	'Installation of resilient floor coverings. Code of practice'

9.3.8 Asphalt finishes

Asphalt finishes shall be suitable for the location and intended use.

Mastic Asphalt floor finishes should be:

- designed and constructed in accordance with BS 8204-5
- grade I or II and 15-20mm thick (which applies to the floor finishes and underlay)
- applied as one coat when used as underlay for other finishes
- in accordance with the floor manufacturer's recommendations when used with a suspended floor system.

9.3.9 Staircase finishes

Also see: Chapter 6.6

Staircase finishes shall permit safe usage and be suitable for their intended use.

The rise and going should remain uniform after application of the staircase finish, including at the top and bottom of the flight, see Clause 6.6.8.

For communal stairs (eg in escape routes in blocks of flats), non-slip nosings or inserts should be:

- provided where specified
- fixed in accordance with the manufacturer's recommendations.

Figure reference table

Figure reference table 9.3

Fig No	Title/Description	Clause	Page
Figure 1	Screed over insulation	9.3.4	3
Figure 2	Location of DPM and insulation on ground-bearing slab	9.3.6	5
Figure 3	Location of DPM, VCL and insulation on precast floor	9.3.6	5



Chapter 9.4



Finishings and fitments

This chapter gives guidance on meeting the Technical Requirements for finishings and fitments (including cupboards and internal trim).

9.4.1	Compliance	01
9.4.2	Provision of information	01
9.4.3	General provisions – cupboards and fitments	01
9.4.4	Finishings and internal trim	01
9.4.5	Joinery	02
9.4.6	Airing cupboards, cupboards, worktops and fitments	02
9.4.7	Ironmongery, prefabricated items and other materials	02
9.4.8	Protection and handover	03

For figure reference tables in this chapter, please go to the end of the chapter



9.4.1 Compliance

Also see: Chapter 2.1

Finishings and fitments shall comply with the Technical Requirements.

Finishings and fitments which comply with the guidance in this chapter will generally be acceptable.

9.4.2 Provision of information

Designs and specifications shall be produced in a clearly understandable format, include all relevant information and be distributed to the appropriate personnel.

Designs and specifications should be issued to site supervisors, relevant specialist subcontractors and suppliers.

9.4.3 General provisions – cupboards and fitments

The builder shall provide fixed and built-in fitments in accordance with the specification.

In kitchens, the specification should allow for:

- preparation and cooking of food
- washing up, drying and storage of dishes and utensils
- storage of dry foods
- storage of perishable foods
- laundering
- storage of domestic cleaning appliances (part of which should be suitable for brooms, upright cleaners and similar equipment)
- 1m circulation space in front of all work surfaces, cupboards and appliances.

A depth of 600mm can be assumed for appliances (where intended but not provided).

Space or facilities for laundering and cleaning items may be provided outside the kitchen area.

Space should be provided for general storage, clothes, linen and bedding. Airing cupboards are required in homes which do not have central or whole home heating.

Kitchen units should be installed in accordance with the manufacturer's instructions, ensuring that they are adequately fixed to a suitable substrate.

Shelving supports should be fixed securely and so that shelves are level.

9.4.4 Finishings and internal trim

Also see: Chapter 6.8

Finishings and internal trim shall be suitable for their location and intended use, securely fixed, and finished to established standards of workmanship.

When fixing trim and components:

- they should be in accordance with the specification
- fireplace surrounds, panelling and features should be complete and suitably joined to the adjacent surfaces
- nails should be punched below the surface of timber, and holes filled
- damage should be avoided (where damage does occur, it should be made good).

Trim and finishings should be:

- sufficiently wide to mask joints around built in fitments, etc allowing for movement and shrinkage
- fixed in accordance with Building Regulations (eg with minimum separation distances where near heat sources)
- selected and installed to give a neat appearance
- installed in accordance with the manufacturer's recommendations.

Architraves should be:

- parallel to frames and linings
- accurately mitred, or scribed, to fit tightly and neatly
- fixed with an equal margin to each frame member
- securely fixed to prevent curling.

Skirting should:

- be mitred and scribed at external and internal angles, as appropriate
- tightly abut architraves
- run level and scribed to floors.

Proprietary trim, skirting and architraves should be fixed in accordance with the manufacturer's recommendations.

9.4.5 Joinery

Wood and wood-based materials shall be of the quality and dimensions required by the design.

Joinery and the materials used should be installed to established standards of workmanship, and have no visible defects after the finish has been applied. Issues that should be taken into account include:

- fit and construction of joints (including finger joints)
- gluing and laminating
- construction of moving parts
- surface finishes.

Relevant standards include:

BS EN 942	'Timber in joinery. General requirements'
BS EN 312	'Particleboards. Specifications'
BS 1186	'Timber for and workmanship in joinery'

9.4.6 Airing cupboards, cupboards, worktops and fitments

Airing cupboards, cupboards, worktops and fitments shall be installed to provide satisfactory appearance and performance. The builder shall provide fixed and built-in fitments in accordance with the design.

Cupboards, worktops and fitments should be:

- checked to ensure they are undamaged before they are installed
- installed as shown in the design (worktops spanning between units may require additional support)
- plumb, level and scribed to wall faces, where necessary.

Cupboards should be installed ensuring that:

- doors operate freely and fit openings closely and evenly
- drawers run smoothly, and locks and catches properly engage.

Cupboards (including wall-hung units) should be securely fixed, using:

- fixings of an appropriate size, and in accordance with the manufacturer's instructions (generally, plugs and screws to masonry and screws to timber)
- the predrilled holes in units and brackets provided by the manufacturer.

Where worktops or unit panels are cut, edges should be sealed using a metal or plastic strip glued to the edge with waterproof adhesive. Alternatively, an appropriate waterproof joint may be used. Sinks and hob units which are inset in worktops, and vanity units, should be sealed with a waterproof joint.

Where appropriate, gaps between fitments and wall tiling should be sealed with a waterproof joint and brought to a smooth finish.

Wardrobes should be fitted with hanging rails, and intermediate supports used where necessary to avoid bending.

Internal doors (including airing cupboard doors) should be fitted in accordance with Chapter 6.7 'Doors, windows and glazing'.

Airing cupboards should:

- be separated from other storage
- have a minimum 0.5m² of easily reached shelving suitable for the airing of clothes
- have a 300mm minimum spacing between shelves
- have a suitable heat source, such as a hot water cylinder
- not have shelving higher than 1.5m.

Figure 1: Airing cupboard requirements

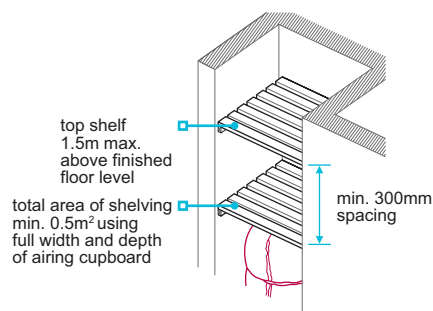

9.4.7 Ironmongery, prefabricated items and other materials

Ironmongery, prefabricated items and other similar materials shall be suitable for the intended use.

Relevant standards include:

- BS EN 1935 'Building hardware. Single-axis hinges. Requirements and test methods'.

9.4.8 Protection and handover

Finishings and fitments shall be suitably protected during construction, and be undamaged at handover.

Appropriate protection should be provided to finishings and fitments (including to doors, trim, balustrades, fireplace surrounds, panelling and other special features) to ensure they are not damaged. Kitchens, including cupboards, doors, fittings and worktops, should be suitably protected.

Prior to completion and handover:

- work should be left in a clean state
- decorating should be completed in accordance with Chapter 9.5 'Painting and decorating'
- temporary coverings and protection should be removed, and the fitments and finishings cleaned and dusted.

Figure reference table

Figure reference table 9.4

Fig No	Title/Description	Clause	Page
Figure 1	Airing cupboard requirements	9.4.6	2



Chapter 9.5



Painting and decorating

This chapter provides guidance on meeting the Technical Requirements for painting and decorating.

9.5.1	Compliance	01
9.5.2	Provision of information	01
9.5.3	Storage	01
9.5.4	Conditions for painting and decorating	01
9.5.5	Timber	01
9.5.6	Steel	02
9.5.7	Walls	02
9.5.8	Wallpapering	03
9.5.9	Other surfaces	03
9.5.10	Completed painting and decorating	03

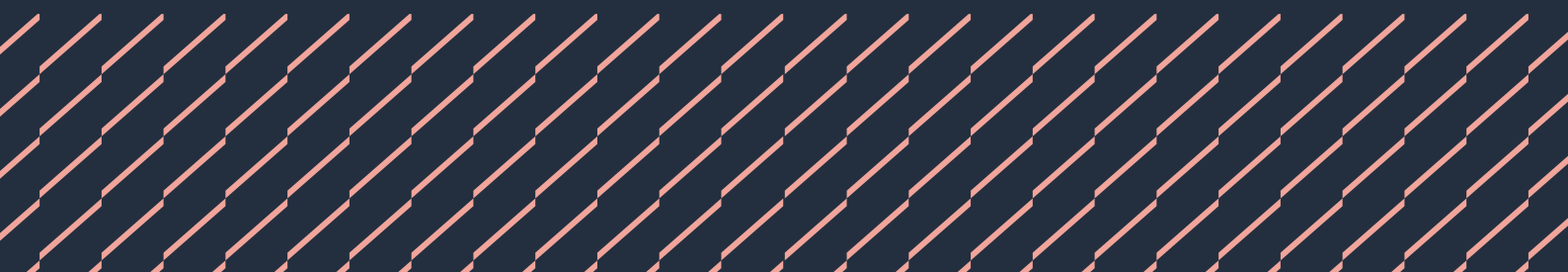

9.5.1 Compliance

Also see: Chapter 2.1

Painting and decorating shall comply with the Technical Requirements.

Painting and decorating that complies with the guidance in this chapter will generally be acceptable.

Paint finishes should be selected and applied in accordance with BS 6150 'Painting of buildings. Code of practice'.

Chapter 9.1 'A consistent approach to finishes' provides further guidance on the quality of painting and decorating finishes.

9.5.2 Provision of information

Designs and specifications shall be produced in a clearly understandable format, include all relevant information and be distributed to the appropriate personnel.

Designs and specifications should be issued to site supervisors, relevant specialist subcontractors and suppliers, and include:

- specification of preparatory work
- schedule of finishes
- details of specialist finishes.

9.5.3 Storage

Materials for painting and decorating shall be adequately protected from the weather.

Painting and decorating materials should:

- be protected against frost before use
- be stored in dry conditions
- not be used where they have been damaged by frost.

9.5.4 Conditions for painting and decorating

Painting and decorating shall take account of the climatic and building conditions to ensure a suitable finish.

The painting and decoration of external surfaces should not be undertaken where:

- weather conditions may adversely affect the completed work
- frost occurs, or is due to occur, before the paint has been applied or has dried
- surfaces are moist
- rain is expected before the paint dries.

When decorating internal walls:

- cold surfaces may cause problems with water-borne paints, even though the air temperature may be above freezing
- paintwork should not be adversely affected by dust
- surfaces should be free from condensation before applying paint and coatings; they should not be applied until the moisture has evaporated from the surface.

9.5.5 Timber

Also see: Chapter 3.3

The painting and decorating of timber and timber-based materials shall be compatible with the species of timber, provide adequate protection and be suitable for the intended use and location. Prefabricated components and joinery shall be finished to a suitable quality, and protected.

When painting or decorating timber, the moisture content should be a maximum of 18%.

Paint and paint systems should be used in accordance with the manufacturer's recommendations, and be compatible with the surface to be decorated.

Decorative finishes applied to timber treated with a fire-retardant must be compatible with the treatment used. Guidance on painting fire-retardant treated timber should be sought from the treatment manufacturer.

Preparation should ensure:

- door and window furniture is removed
- unsound wood, loose or highly resinous knots, etc are cut out, replaced and made good
- raised grains, tool and machine marks are removed
- surfaces are refinished with fillers and glasspaper as appropriate
- nail holes, splits and other imperfections are stopped
- sharp arrises are rubbed down (to enable an even coating)
- surfaces are free from dirt, dust and moisture
- where there is deterioration of the primer or seal coat, surfaces are rubbed down and a second coat applied
- where joinery is delivered preprimed, priming meets the requirements in this chapter
- where joinery is prefabricated, the first coat of paint or stain is applied before fixing.

Knotting should:

- comply with BS 1336 'Specification for Knotting' (this may not be effective against heavy exudation of resin)
- be applied using a brush, or as part of the priming process for joinery.

One full round coat of primer should be applied to all surfaces to be painted, including:

- hidden surfaces of external woodwork
- rebates for glazing and backs of glazing beads.
- cut ends of external woodwork

Primers should be in accordance with BS 7956 'Specification for primers for woodwork'.

Where specified, paint or stain should be applied to external timber to provide protection from moisture. Primer, paint and stain finishes should be compatible with any preservative treatment which may have been used.

Undercoat and gloss should be applied ensuring that it provides a satisfactory finish, and:

- it is not thinned (unless recommended by the manufacturer)
- a minimum of one priming coat, one undercoat and one finishing coat are used (unless an alternative recommendation is made by the manufacturer)
- each application is a full round coat and surfaces are lightly rubbed down with glasspaper between coats
- each coat is applied within one month of the previous.

Stain and varnishes should be:

- applied as recommended by the manufacturer to provide appropriate cover
- applied when the substrate is dry
- applied to surfaces which have been suitably prepared to provide adequate adhesion and an acceptable appearance
- suitable for the species of timber.

Varnish should be applied with a minimum of three coats on interior surfaces. On exterior surfaces, clear varnishes will have a short service life and require regular maintenance to avoid premature failure; as a result the use of clear varnishes should be avoided.

Stain should:

- be a two-coat system or be in accordance with the manufacturer's recommendations
- not be applied to door or window rebates which are to be glazed with linseed-oil putty.

BS EN 927-1 provides guidance on exterior wood coating systems.

Prefabricated joinery and components should be:

- protected from damage
- stored under cover and primed, where supplied untreated, as soon as possible after delivery
- supplied with, or given, a coat of primer to all surfaces before fixing
- reprimed where primer is damaged.

9.5.6 Steel

Also see: Chapter 6.5

Decorative finishes to steelwork shall provide adequate protection and be suitable for the intended use and location.

Decorative finishes may be applied to galvanised steel following suitable preparation with a mordant wash.

Decorative finishes applied to steelwork that has been protected by coatings (including intumescent paint for fire resistance) in accordance with Chapter 6.5 'Steelwork', must be compatible with the protective coating. The manufacturer's recommendations should be followed. Any damage to the protective coatings should be made good prior to decorative finishes being applied.

9.5.7 Walls

Walls shall be finished to provide an even and consistent appearance, to established levels of workmanship. Issues to be taken into account include:

- a) external masonry and rendering
- b) plaster and plasterboard surfaces.

External masonry and rendering

Paint or decorative finishes to external masonry and rendering should:

- be appropriate for the substrate, and be in accordance with the manufacturer's recommendations
- not be applied to external brickwork or render where they could trap moisture in the construction and cause frost damage, sulfate attack or other detrimental effects.
- be applied to surfaces which are clean, free from dust and loose deposits

Where bricks have no upper limit on their soluble salt content, the brick manufacturer's written agreement to the application of a finish should be obtained.

Where the decorative system is part of the weather resistance of the rendering, it should be assessed in accordance with Technical Requirement R3.

Where surfaces have varying suction, they should be stabilised with a treatment recommended by the manufacturer.

Plaster and plasterboard surfaces

A sealing coat should be applied to dry lining, and surfaces prepared for decoration, in accordance with the manufacturer's recommendations.

Plaster and plasterboard surfaces should be prepared in accordance with the manufacturer's recommendations and the design. Where plaster and skim coat is applied to plasterboard:

- surfaces should be visibly sound, without signs of powdering or crumbling
- joints should be completed and cracks, nail holes and surface imperfections filled
- the surface should be rubbed down with glasspaper and dusted, where necessary
- dirt and loose surface deposits, especially dust from sanding of filled joints, should be removed
- surfaces should be stabilised, either with a coat of thinned paint or with a sealant as recommended by the manufacturer
- a minimum of two coats of paint should be applied
- plaster should have adequate time to dry before decorating begins.

Where building boards are used, coatings should be in accordance with the board manufacturer's recommendations.

9.5.8 Wallpapering

Wallpapering shall be finished to provide an even and consistent appearance, to established levels of workmanship.

Where wallpaper or coverings are used:

- surfaces should be dry, even and smooth before wallpaper is applied
- surfaces should be sized or sealed as necessary
- adhesives should be in accordance with the wallpaper manufacturer's recommendations
- they should be properly aligned and neatly fixed
- electrical switch plates should be temporarily removed and the papering accurately trimmed so that it will tuck behind the fitting upon completion.

9.5.9 Other surfaces

Surfaces shall be finished to provide an even and consistent appearance, to established levels of workmanship.

For glazing rebates in windows and doors treated with stains:

- linseed-oil putty should not be specified
- appropriate sealants should be used in accordance with the manufacturer's recommendations.

The insides of metal gutters (other than aluminium) should be painted with a suitable protective paint.

Non-ferrous pipework (eg copper pipes) should be painted with the normal decorative finishes.

9.5.10 Completed painting and decorating

Completed paintwork shall be to established levels of workmanship and suitably protected.

Painting and decorating should be complete, and:

- surfaces that are not intended to be painted should be free of paintmarks
- evenly applied, free from conspicuous runs or prominent brush marks, and the background or undercoat should not be visible
- where ironmongery has been removed, it should be correctly replaced
- removed and reapplied where spilt, splashed or badly applied
- protected against dirt and damage until handover.



Technical Disclaimer

The NHBC Standards are produced by NHBC as guidance solely for our builder customers as to how to interpret the technical requirements in relation to the warranty cover provided by NHBC under its Buildmark, Buildmark Choice, Buildmark Link, Buildmark Solo, Buildmark Connect or any similar product from time to time. It has not been created or intended for distribution or use outside of that purpose. The information contained in the NHBC Standards do not constitute advice and is not to be relied upon by any third party. Nothing in the NHBC Standards is intended to, nor should it be taken to, create any legal or contractual relationship. Any third party who chooses to rely upon the information contained in the NHBC Standards shall do so entirely at their own risk and NHBC accepts no duty of care or liability, however caused, in connection with its use or reliance by any third party.



Standards

2024

NHBC, NHBC House, Davy Avenue, Knowlhill, Milton Keynes, Bucks MK5 8FP

National House-Building Council (NHBC) is authorised by the Prudential Regulation Authority and regulated by the Financial Conduct Authority and the Prudential Regulation Authority in respect of carrying on its insurance business and its insurance distribution activities.

NHBC is registered in England and Wales under company number 00320784. NHBC's registered address is NHBC House, Davy Avenue, Knowlhill, Milton Keynes, Bucks, MK5 8FP. Note that only certain parts of NHBC's products and services are within the scope of UK financial services regulation. For more information on our products and services, please see our website nhbc.co.uk or your NHBC product documentation.