

Internal services

This chapter gives guidance on meeting the Technical Requirements for internal services, including:

- the supply of hot and cold water services
- vented and unvented hot water storage systems
- plumbing
- gas services
- electrical installations

8.1.1	Compliance	01
8.1.2	Provision of information	01
8.1.3	Water services and supply	01
8.1.4	Cold water storage	04
8.1.5	Gas services	05
8.1.6	Electrical services	06
8.1.7	Meter boxes	11
8.1.8	Hot water services	11
8.1.9	Unvented storage systems	13
8.1.10	Soil and waste systems internal	15

For figure reference tables, please go to the end of each chapter.



Definitions for this chapter

Mixing (table 8)	Relates to the cooling effect when incoming cold water mixes with the hot water storage volume cooling the tank contents reducing performance and wasting energy
Stratification (table 8)	Relates to the tank volume not being cooled by the introduction of cold water when running the hot volume off
Thermostatic mixing valve (TMV)	A valve that allows the 60C water leaving the storage cylinder to be blended with cold mains water to achieve the designed temperature
Wholesome water	Wholesome' water is fit to use for drinking, cooking, food preparation or washing without any potential danger to human health

8.1.1 Compliance*Also see: Chapter 2.1***Incoming utilities shall comply with the Technical Requirements and take account of service entries, ground hazards and chemical attack.**

Internal services which comply with the guidance in this chapter will generally be acceptable.

Adequate precautions against ground hazards and the entry of gas ie, radon or gas, from landfill sites, should be provided as necessary. Further guidance can be found in BRE Report 211 'Radon: Guidance on protective measures for new dwellings (including supplementary advice for extensions, conversions and refurbishment projects)' and BRE Report BR212 'Construction of new buildings on gas-contaminated land'. Also see chapter 4.1.

8.1.2 Provision of information**Designs and specifications shall be produced in a clearly understandable format, include all relevant information and be distributed to the appropriate personnel.**

Provision of information is important as it allows for energy efficient use of the building and common methods adopted to prevent overheating.

Clear and fully detailed drawings should be available on site to enable work to be carried out in accordance with the design. Designs should be issued to site supervisors, relevant specialist subcontractors and suppliers, and where used include the following information:

Common information required all parts:

- fixing schedule
- a full set of current drawings
- indication of which manufacturer and/or installer is responsible for each system and interface
- commissioning schedule
- manufacturers' specifications
- interface details
- on-site testing requirements
- type and spacing of clips and fixings
- type and location of ancillary components, including those used for fire safety and acoustic purposes
- commissioning certificates
- cold water pipe runs
- water efficiency calculations.

8.1.3 Water services and supply*Also see: water regulations and guides***Water services shall be based on the pressures and flow rates supplied from the incoming main. Components shall be selected and installed to ensure satisfactory service for the life of the system, with suitable precautions taken against corrosion and damage. Issues to be taken into account include:**

- 1) suitability of materials and components
- 2) adequate supply
- 3) durability
- 4) protection from the cold
- 5) wholesome water
- 6) water efficiency.

8.1.3.1 Suitability of materials and components

Relevant standards for materials and components used in domestic water systems include:

BS EN 806	'Specifications for installations inside buildings conveying water for human consumption'
BS EN 12897	'Water supply. Specification for indirectly heated unvented (closed) storage water heaters'
BS EN 1057	'Copper and copper alloys. Seamless, round copper tubes for water and gas in sanitary and heating applications'
BS 1566	'Copper indirect cylinders for domestic purposes'
BS 3198	'Specification for copper hot water storage combination units for domestic purpose'
BS 7291	'Thermoplastics pipe and fitting systems for hot and cold water for domestic purposes and heating installations in buildings'
BS 8558	'Guide to the design, installation, testing and maintenance of services supplying water for domestic use within buildings and their curtilages. Complementary guidance to BS EN 806'

8.1.3.2 Adequate supply

The design and installation of the water services supply should:

- be in accordance with Building Regulations, statutory requirements and the recommendations of the water supplier
- ensure drinking water is provided at the kitchen sink direct from the supply pipe or, where this is impracticable, from a storage cistern containing an adequate supply of drinking water
- be based on a minimum 1.5 bar dynamic pressure at the stop valve inside the home
- ensure a minimum 20L/min flow rate is available at the stop valve inside the home
- account for pressure and flow rate reductions (a wider supply pipe may be required inside the home)
- account for pressure fluctuations and surges, which may occur within the system and potentially damage fittings (surge arresters may be required)
- ensure that stop valves within the curtilage and outside the home are protected by a shaft or box
- ensure service pipes are a minimum of 750mm below the ground surface – where this is not possible, adequate precautions should be taken against frost and mechanical damage
- ensure that underground ducts are sealed at both ends to prevent the entry of fluids, vermin and insects
- be of materials which are safe and minimise the risk of corrosion
- be in accordance with the recommendations of the water supplier, including compatibility of the supply with the materials and fittings
- the water system should be capable of being drained (hot and cold services separately).

8.1.3.3 Durability

The hot and cold-water service should be installed using corrosion resistant pipes and fittings.

In areas where pitting corrosion of copper cylinders occurs, it may be necessary to fit aluminium protector rods. These should be fitted during manufacture in accordance with the relevant British Standard. Sacrificial anodes should be installed where required by the water supplier.

8.1.3.4 Protection from the cold

Also see: Clause 7.2.15

To reduce the risk of freezing, or condensation forming on the pipework, water services should be located in the warm envelope of the home. Where possible, water pipes should be below the main roof insulation.

Particular care is needed with cisterns, vent pipes, bends and junctions, especially near openings to the outside air, such as eaves.

Where they are located in unheated spaces, they should be insulated and not affected by cold. Insulation should be provided:

- around water services, including pipework (in accordance with Tables 1 and 2)
- as specified in the design (but not beneath a cold-water tank)
- on each side of raised tanks in unheated roof spaces
- even where it is below the main roof insulation. See figure 1, 2 & 3
- in accordance with BS EN 806 and BS 8558.

Figure 1: Protection from the cold - loft space

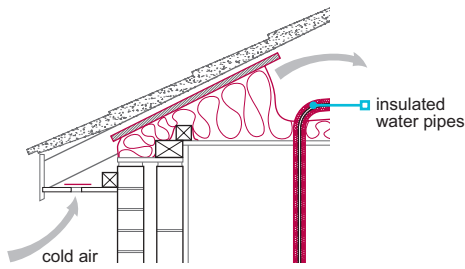

Figure 2: Protection from the cold - header tanks

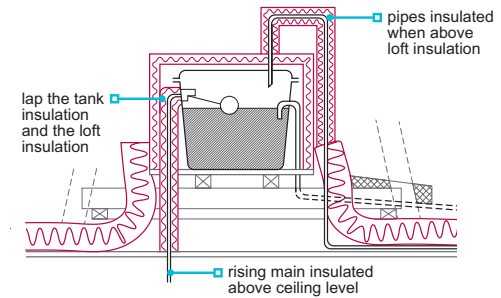

Figure 3: Pipe insulation thickness

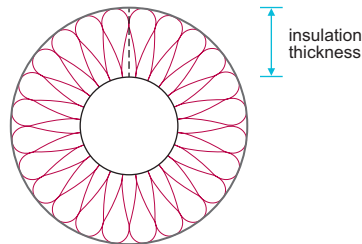

Table 1: Minimum insulation thickness to delay freezing inside domestic premises for cold water systems taken from BS 5422:2009 table 30. See figure 3

Outside diameter (mm)	Thermal conductivity at 0°C W/(m.K)			
	0.025	0.035	0.045	0.055
	Thickness of thermal insulation (mm)			
15	30	62	124	241
22	12	20	30	43
28	8	12	17	23

The conditions assumed for the table are:

- air temperature -6°C
- water temperature +7°C
- permitted ice formation 50%
- evaluation period 12 hours
- installation inside the building
- for practical reasons if the pipe and insulation diameter are too large to be applied in practice then insulation with a lower thermal conductivity should be used.

Table 2: Examples of insulating materials:

Thermal conductivity W/(m.K)	Material
Less than 0.020	Rigid phenolic foam
0.021 to 0.035	Polyurethane foam
0.040 to 0.055	Corkboard
0.055 to 0.07	Exfoliated vermiculite (loose fill)

Where the floor is of suspended construction, the underfloor water service should be insulated as it passes through the ground and the ventilated space. See figure 4

Figure 4: Underfloor soil pipe insulation

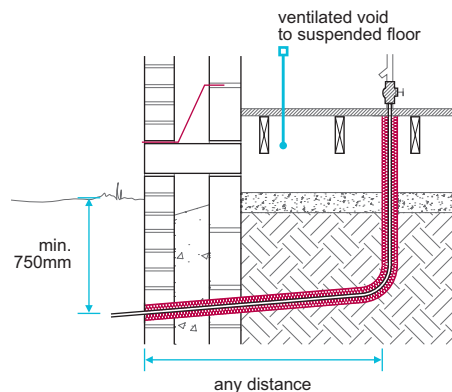

8.1.3.5 Wholesome water

There must be suitable installation for the provision of wholesome water to any place where drinking water is drawn off.

8.1.3.6 Water efficiency

Water efficiency should be accounted for in any design to prevent waste and undue consumption.

Water efficiency can either be by a fittings approach or a water efficiency calculator or other approved method acceptable to NHBC.

8.1.4 Cold water storage

Cold water service shall be provided in accordance with statutory requirements and be adequate. Issues to be taken into account include:

- 1) cold water storage
- 2) cisterns
- 3) cisterns support
- 4) warning and overflow pipes
- 5) access.

8.1.4.1 Cold water storage

Cold water storage should be provided with suitable capacity and include primary feed cisterns where indirect water heating systems are installed. Cold water storage should be provided:

- to supply an open vented hot water storage system (where required by the water supplier)
- to supply cold water outlets (where not connected to the mains supply)
- designs should prevent undue consumption, contamination and water wastage.

8.1.4.2 Cisterns

Cisterns should:

- be accessible for inspection and maintenance
- be protected by a rigid close-fitting cover (non-airtight) that also excludes light and insects
- have holes neatly formed with a cutter in the positions shown in the design
- be suitably supported.

8.1.4.3 Cistern support

The cistern bottom should be continuously supported by materials such as:

- softwood boarding
- plywood to BS EN 636-2s
- chipboard type P5 to BS EN 312
- oriented strand board type OSB3 to BS EN 300, laid with the stronger axis (as marked on board) at right angles to the bearers.

8.1.4.4 Warning and overflow pipes

Warning and overflow pipes should:

- be provided at each cold-water cistern, to a suitable external discharge, unless permitted by water regulations where it may be internal if it is conspicuous
- be adequately sized (19mm internal diameter (ID) minimum)
- be situated 25mm above the shut-off water level in the cistern
- be in accordance with water regulations, terminate vertically downwards or be fitted with a horizontal tee where it discharges. And may dip below the water level where permitted by the water regulations.

8.1.4.5 Access

Access for cold water storage should be:

- provided to the main roof space and voids that contain cisterns and tanks, etc (not required to roof spaces containing only water pipes)
- be via an opening (access hatch) with a minimum width of 520mm in each direction
- not be located directly over stairs or in other hazardous locations
- include a minimum 1m² platform located for maintenance purposes
- have securely fixed boarded walkways between the opening and the cistern or other permanent equipment (boarding should be securely fixed without compressing the insulation).

8.1.5 Gas services

Also see: Chapters 6.2, 6.8, 8.6 and BS 6400 and BS 6891

Gas service installations shall be adequate and comply with the gas safety regulations and be in accordance with relevant standards and codes to ensure safe and satisfactory operation. Gas service installations should take into account:

1) gas service installation

2) corrugated stainless steel tube

8.1.5.1 Gas service installations

Gas service installations should ensure:

- service pipework up to and including the emergency control valve and meter is in accordance with the requirements of the gas transporter, gas supplier and primary meter owner
- installation of pipework and appliances complies with relevant standards and codes including those published by the Institution of Gas Engineers and Managers (IGEM), British Standards Institute (BSI) or Gas Safe Register (GSR)
- where there is a gas supply to the home, a gas point at the cooker space should be provided. This is not required where an electric hob is provided
- where gas pipework is to be installed in timber frame, allowance is made for differential movement
- installation of gas pipes will not impair the structural stability, fire/smoke resistance, damp proof course, radon barrier, hazardous ground membrane, thermal or sound insulation of the building
- gas installation pipes are not over bent, stressed, or installed where subject to mechanical damage. See figure 5-9.

Figure 5: Masonry brick and block plastered

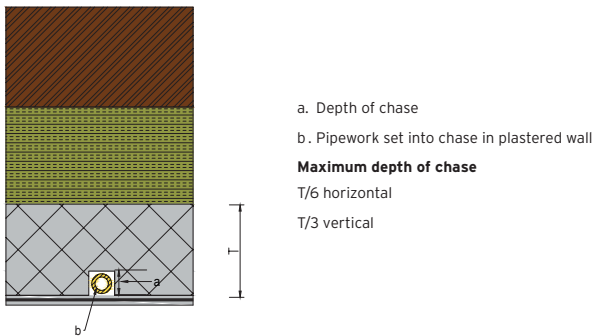

Figure 6: Dry lined walls on batons

CSST pipes installed behind dry lining shall be encased by building material

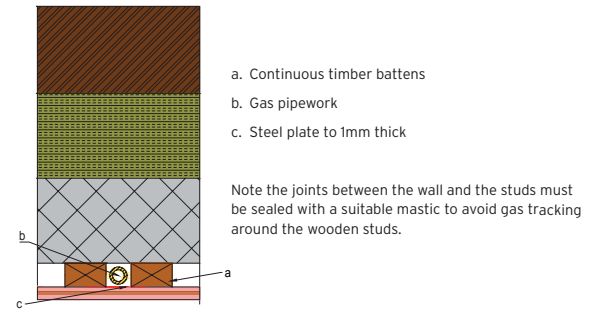

Figure 7: Dry lined walls on dabs

CSST pipes installed behind dry lining shall be encased by building material

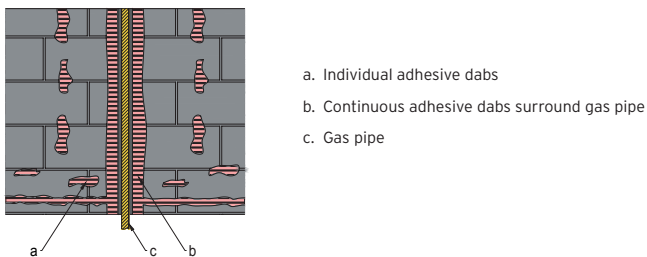

Figure 8: Timber-frame or light steel construction wall

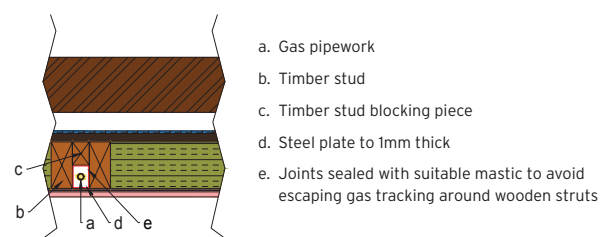
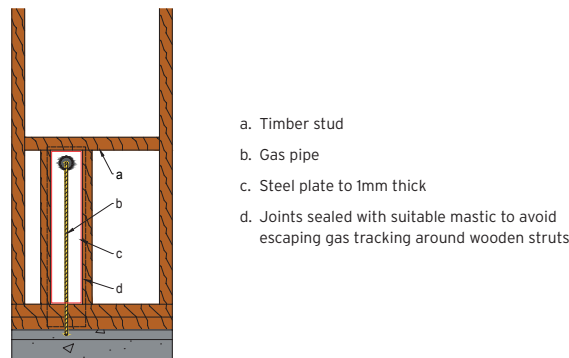

Figure 9: Installed in a timber frame or light steel construction wall



8.1.5.2 Gas pipe installations incorporating Corrugated Stainless Steel Tube (CSST)

Gas pipe installations Incorporating Corrugated Stainless Steel Tube (CSST):

- conform to the corrugated stainless steel tube benchmark scheme with secondary cover for use as a secondary containment or BSI PP1644 flexible ventilated ducting for corrugated stainless steel tubing
- be certified by a UKAS accredited test body and tested in accordance with BS EN ISO 13823 and BS EN ISO 11925-2 and classified in accordance with BS EN 13501-1 and achieve B-s1, d0 or better
- be adequately supported in line with manufacturer's recommendations
- not be mixed with other proprietary brands of CSST or fittings
- not be buried in concrete floors, unless it is appropriate for the application, and confirmation from the manufacturer confirms it is suitable for this purpose.

CSST tubing without ducting shall meet the "tightness in case of fire requirements" of BS EN 15266, test method BS EN 1775 Annex A procedure A.

Where any pipe ducting used that is intended to be fire resistant it should be at least the same level as fire resistance as the protected area it is installed in. The fire resistance of the ducting shall be tested, evaluated and fire rated to the relevant parts of BS 476-24.

8.1.6 Electrical services

Also see: Chapter 8.6

Electrical installations shall be provided in accordance with relevant regulations, codes and standards. The installation shall ensure safe and satisfactory operation and be protected from chemical attack.

Items to be taken into account include:

- 1) installation
- 2) provision of sockets
- 3) cable positions
- 4) consumer units
- 5) fire rated partitions
- 6) lighting outlets
- 7) cooking spaces
- 8) built-in appliances
- 9) metal splashbacks
- 10) electrical supply to gas appliances
- 11) TV
- 12) smoke alarms
- 13) electric vehicle charging points
- 14) electronic communications
- 15) lightning protection.

8.1.6.1 Installation

Electrical services and installations should:

- comply with BS 7671 'Requirements for electrical installations'
- comply with BS 6004 'Electric cables. PVC insulated and PVC sheathed cables for voltages up to and including 300/500 V, for electric power and lighting'
- have fittings and components located in accordance with relevant Building Regulations
- be installed in accordance with the manufacturer's recommendations
- ensure cables are not placed under, against or within thermal insulation, unless they have been appropriately sized and derated
- ensure PVC covered cables are not in contact with polystyrene insulation
- be provided with a completion certificate by the electrical contractor to the builder. This certificate to cover all aspects of the installation, including earth bonding
- incorporate appropriate automatic devices for protection against overcurrent or leakage. Where electrical items contain electronic components or create a Direct Current (DC) waveform in an Alternating Current (AC) supply then the RCD should be a suitable type to prevent nuisance tripping eg heat pumps, solar photo voltaic, micro wind, electric vehicle charging points, circulating pumps or induction hobs, USB charging sockets
- be supported such that they will not be liable to premature collapse in the event of a fire. This can be achieved by using steel containment systems (either in or on) and precludes the use of non-metallic cable clips or ties as the sole means of support where cables are clipped direct to exposed surfaces. Suitably placed steel or copper clips, saddles would be acceptable. (Plastic rawlplugs with a steel clip will be acceptable if suitably sized for the screw and load)

- be earthed, where electrical sockets, fused spurs or light switches use metal back boxes that are fully recessed and covered by the faceplate. The earth terminal on the sockets should be used to connect the earth wire to. If no earth terminal is provided as in the case of a light switch the metal back box requires earthing
- not leave exposed wiring for homeowners to connect their own electrical fittings after occupation. All cables should terminate in a suitable proprietary electrical enclosure complying with the appropriate British Standard such as a recessed back box with cover or a temporary light fitting eg, batten lamp holder as appropriate
- be sited to provide reasonable access to homeowners as shown in table 5.

Table 3: Minimum height of switches/sockets and controls

Region	Height of switches/sockets & controls above floor level
England Approved Document M1	450mm - 1200mm
Wales Approved Document M1	450mm - 1200mm
Scotland Technical Handbook 4.8.5	400mm - 1100mm
Northern Ireland Technical Booklet R	400mm - 1200mm

8.1.6.2 Provision of sockets

Rooms should be provided with the minimum number of 13A outlets listed in Table 4 (dual outlets count as two).

Table 4: Minimum number of outlets

Room	Outlets	Notes
Kitchen/utility	8	Where homes have separate areas, the kitchen should have a minimum of four outlets and the utility room four. Where appliances are provided, a minimum of three outlets should be free for general use. Located above the worktop level
Living or family room	8	A minimum of two outlets near the TV aerial outlet
Bedrooms	6 (4)	A minimum of six outlets for the main bedroom and a minimum of four outlets for other bedrooms
Dining room	4	
Landing	2	
Hall	2	

8.1.6.3 Cables positions

Cables without special protection, such as an earthed metal conduit, should be positioned:

- vertically or horizontally from the outlet or switch being served
- within the shaded zone in the diagram. See figure 10 or
- a minimum of 50mm from the surface of a wall, or a minimum of 50mm from the top or bottom of a timber joist or batten in a floor or ceiling.

Where the position of switches or sockets can be determined from the reverse side of the wall or partition, the zone on one side of the wall or partition applies to the reverse side.

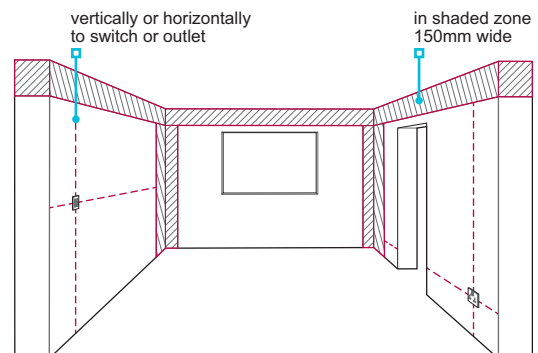
Figure 10: Safe location of cables

8.1.6.4 Consumer units

Consumer units should:

- have their enclosure manufactured from non-combustible material or be enclosed in a cabinet or enclosure constructed of non-combustible material (ferrous metal eg steel, is deemed to be an example of non-combustible material)
- be compliant with BS EN IEC 61439-3 and where installed for use by ordinary persons have an IP 2XC rating
- not have any gaps between blanking pieces and circuit breakers larger than IPX2C requirement (hazardous parts within the enclosure cannot be contacted by a wire probe 2.5mm diameter and 100mm long)
- provide space for the installation and subsequent repair or replacement in line with manufacturer’s recommendations
- be sited to provide reasonable access to homeowners as shown in table 5.

Table 5: Minimum height of consumer units

Region	Minimum height of consumer units above floor level
England Approved Document M4(2)	1350mm - 1450mm
Wales Approved Document M1	1200mm - 1400mm
Scotland Technical Handbook 4.8.5	900mm - 1200mm
Northern Ireland Technical Booklet R	Based on controls 1200mm - 1400mm

- where multiple rows of consumer units are utilised BEAMA recommend the bottom row of switches located 1350mm – 1450mm
- be sited to provide reasonable access for consumers, a minimum of 300mm to an internal corner (measured to the centre line of the socket or switch)
- be labelled such that each circuit protected by a fuse or circuit breaker can easily be identified
- where labels/notices are not provided the Electrical Installation Certificate, complete with guidance for recipients as detailed in appendix 6 of the IET wiring regulations should be made available for inspection on site
- where labels/notices are fitted they should be fixed in a permanent position at or near the origin of every installation. The most convenient location for these notices is usually on the consumer unit. Any notice should be of a durable material and indelibly marked. See figure 11.

Figure 11: Notice examples

For periodic Inspection and Testing the label shall read as follows:

Important

This installation should be periodically inspected and tested and a report on its condition obtained, as prescribed in BS 7671 Requirements for Electrical Installations

Date of last inspection.....

Recommended date of next inspection.....

Where RCDs are provided, a notice saying:

Important

This installation, or part of it, is protected by a device which automatically switches off the supply if a fault develops. Test six-monthly by pressing the relevant test button(s) which should operate the device. Afterwards, manually switch on the device. If the device does not operate, or indicates a fault, seek expert advice

- Have a minimum of 300mm measured horizontally to the edge of any bowl of a sink or wash basin opening to avoid splashing from the sink or basin. General guidance is to avoid positioning a consumer unit immediately above or alongside a sink and where space exists an accessory should be located beyond the drainer. See figure 12.

Figure 12: Horizontal distance of electrical items to sinks

Diagram 1 - wash basin

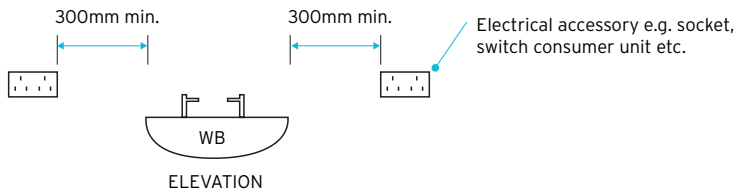
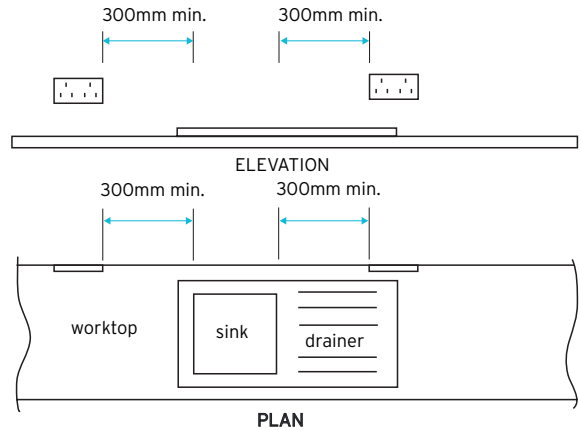

Diagram 2 - sink



8.1.6.5 Fire rated partitions

Electrical installations installed in fire rated partitions should:

- comply with the requirements for cable, conduits, sockets and provision as specified in BS 7671
- not impair the fire resistance of the structure to any means of escape. The provision of any electrical item must maintain the integrity of the compartmentation of the original building design
- where intumescent pads (putty pads) or lined backing boxes are used, they should hold satisfactory assessment, in accordance with R3a ii, have an appropriate period of fire resistance, be suitable for the intended application and be used in accordance with the manufacturer's recommendations.

8.1.6.6 Lighting outlets

Lighting outlets should be provided:

- in each room, hall, landing and staircases
- with two-way switching at each floor level in a staircase
- in the common areas of homes and controlled by either manual switching or automatic light-sensitive controls.

8.1.6.7 Cooking spaces

Cooking spaces should:

- have a minimum 30A supply which is suitably switched and terminated
- have a 13A socket outlet where there is a gas supply
- where provided, have cooker panels located to the side of the cooker space
- have a minimum of 100mm measured horizontally from an electrical accessory to the edge of a freestanding cooker or individual hob. See figure 13.

Figure 13: Built-in appliances. Horizontal distance of electrical items to hobs

Diagram 3 - Hob

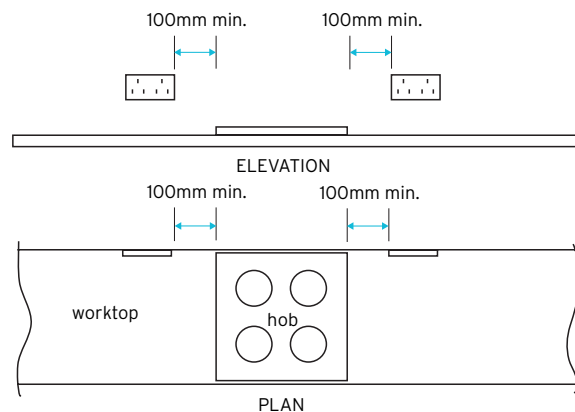

8.1.6.8 Built-in appliances

Where appliances are built in:

- isolation should be reasonably accessible and in compliance with the manufacturer's recommendations
- disconnection points should always be local to the appliance to enable isolation without affecting the use of other electrical appliances or equipment in the same circuit
- disconnection should not require the removal of the appliance from its housing to access and operate.

8.1.6.9 Metal splashbacks

The Institute of Electrical Engineers have confirmed that earth bonding is not required to metal splashbacks in kitchens including those splashbacks containing electrical accessories such as socket outlets.

8.1.6.10 Electrical supply to gas appliances

Also see: Clause: 8.3.2.7

Where a gas appliance requires an electrical supply, a suitable fixed spur or socket outlet should be provided.

8.1.6.11 TV

Aerials are not required; however, one of the following should be provided:

- a concealed, coaxial cable from the roof void to a terminal outlet in the main living room
- a conduit and draw wire or suitable alternative.

8.1.6.12 Smoke alarms

Smoke alarms should be installed within loft spaces where electrical equipment is present ie, solar PV, inverters, batteries or boilers. Where smoke alarms are required they should comply with BS 5839-6 and have a mains power supply from either:

- an independent circuit with no other electrical equipment connected other than a dedicated social alarm control unit or a mains powered carbon monoxide alarm (CO) interlinked if the manufacturer's instructions allow this
- a separately electrically protected regularly used lighting circuit in which case there should be a means of isolating the smoke alarm from the lighting circuit for maintenance.

If more than one smoke alarm is interconnected, then they should all be isolated by one single circuit (unless the interconnection is via remote communication).

Where used smoke alarms should be labelled appropriately to prevent the device being inadvertently disconnected. Labels should be:

- provided to any isolator stating, "smoke alarm is fitted do not switch off"
- provided to any lighting circuit isolator stating, "caution smoke alarms connected to this circuit do not switch off".

8.1.6.13 Electric vehicle charging points

Where electric vehicle charging points are installed considerations should be given to:

- technical requirements
- product certification
- operative competency
- manufacturer's instructions
- location to not cause hazard or nuisance
- serviceability.

8.1.6.14 Electronic communications

Where electronic communications are installed considerations should be given to:

- technical requirements
- distribution point
- common access point
- public electronic communications networks.

8.1.6.15 Lightning Protection

Lightning protection where used should comply with the relevant standards and be appropriate for the location installed:

BS EN 62305-1-5	Protection against lightning
PD 62305-2: 2014	Flash density map 2014. Supplement to BS EN 62305-2
BS EN IEC 62561-1	Lightning protection system components
BS EN IEC 62561-2	Lightning protection system components
IEC 60068-2-52	Environmental testing: salt mist, cyclic (sodium chloride solution)
IECISO 6957	Copper alloys: ammonia tests for stress corrosion resistance
ISO 22479	Corrosion of metals and alloys – sulfur dioxide test in a humid atmosphere

8.1.7 Meter boxes

Also see: Clause: 6.1.17

Openings in walls for meter cabinets shall be structurally adequate and prevent dampness entering the home.

Meter boxes and associated equipment should be located to be reasonably accessible and not subject to damage, guidance should be sought from the appropriate Gas Distribution Operator and/or Distribution Network Operator for electrical installations. Issues to take into account include:

- 1) domestic meter boxes
- 2) openings.

8.1.7.1 Domestic meter boxes

Domestic meter boxes may be of the following type:

- built-in (to the outer leaf of the wall)
- surface-mounted (on an external wall)
- incoming supply to the meter box should be in accordance with the service providers requirements.

8.1.7.2 Openings

Openings set into external walls should be:

- provided with DPCs and cavity trays (refer to Section 6.1.7 for further guidance). See figure 14
- provided with lintels (except for purpose-designed built-in meter boxes)
- provided with insulation carried past meter box to avoid cold bridging. Any reduction in thickness to be accounted for in the thermal assessment of dwelling
- have weephole positions/openings a minimum 180mm from edges of the inbuilt gas meter box and located in a perp joint. See figure 15.

Figure 14: Cavity tray with inset meter box

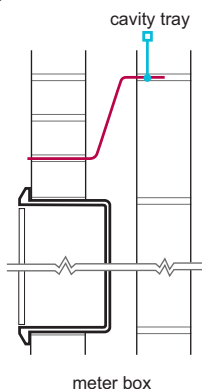
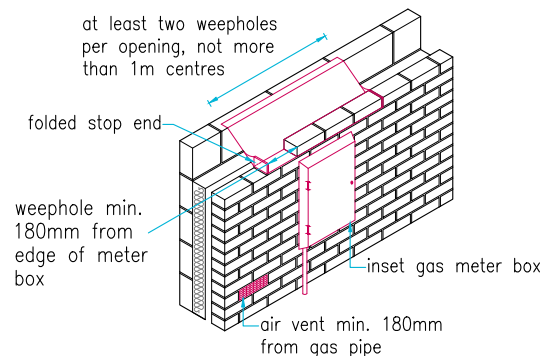

Figure 15: Weephole position with inset meter box



8.1.8 Hot water services

Also see: Chapter 8.6 and BS 8558

Hot water services shall be provided in accordance with statutory requirements and be adequate for the demand and consumption. Issues to be taken into account include:

- 1) design
- 2) location
- 3) immersion heaters
- 4) vented storage cylinders.

8.1.8.1 Design

Hot water services should be designed in accordance with Tables 6, 7 and 8, and

- the minimum flow rate should be in accordance with the statutory requirements and generally be available; it may be less where the pressure and flow rate of the incoming supply falls below 1.5 bar
- have the design flow rate available at each outlet when the total demand does not exceed 0.3L/s (where simultaneous discharge occurs, the flow rate at individual outlets should not be less than the minimum rate).

Table 6: Flow rate and temperature requirements

Outlet	Design flow rate ⁽¹⁾		Minimum flow rate ⁽²⁾		Supply temperature °C ⁽³⁾
	L/sec	(L/min)	L/sec	(L/min)	
Bath (from storage)	0.30	(18)	0.15	(9)	48
Bath (from combi)	0.20	(12)	0.15	(9)	40
Shower (non-electric)	0.20	(12)	0.10	(6)	40
Wash basin	0.15	(9)	0.10	(6)	40
Sink	0.20	(12)	0.10	(6)	50

Notes

- 1 The design flow rate should be used to establish the hot and cold pipe sizes to provide the flow rate quoted at each outlet when that outlet is used on its own.
- 2 The minimum flow rate should be available at each fitting when that fitting is used simultaneously with one or more other fitting(s) as shown in Table 4.
- 3 The supply temperature is the temperature at the outlet. In accordance with BS 8558 the water temperature at an outlet or thermostatic mixing valve should be at least 50°C within 1 minute of running the water.

Table 7: Hot water demand and simultaneous use

Bathroom		Shower room		Hot water demand ⁽⁵⁾	
Bath only	Bath + Shower ⁽¹⁾	1st Shower room	2nd Shower room	L/sec	(L/min)
✓ ⁽²⁾				0.20	(12)
		✓ ⁽³⁾		0.15	(9)
✓		✓		0.25	(15)
✓		✓	✓	0.35	(21)
	✓ ⁽²⁾			0.20	(12)
	✓ ⁽⁴⁾	✓		0.20	(12)
	✓ ⁽⁴⁾	✓	✓	0.30	(18)
		✓	✓	0.20	(12)

Notes

- 1 Shower may be over the bath or in a separate enclosure within the bathroom.
- 2 Demand based on 'Design' flow rate of bath.
- 3 Demand based on minimum acceptable boiler output.
- 4 Demand based on use of the shower in preference to the bath.
- 5 The hot water system should supply at least the hot water demand stated and take account of distribution heat losses through the pipework. The suitability of instantaneous systems (combination boilers) will be limited by their performance as quoted by the boiler manufacturer.

Hot water storage should comply with the minimum capacity in Table 8 (based on a draw-off temperature of 60°C), and where appliances require greater volumes, the capacity should be increased accordingly.

The volumes shown in table 8 are calculated using Annex B BS8558. Volumes have been rounded to common cylinder volumes available.

Table 8: Minimum storage requirements

Usage Example	Heat input to water at 60°C					Cylinder Type
	3kW	6kW	10kW	15kW	20kW	
One Shower (Smaller dwelling)	60L	60L	60L	60L	60L	With stratification
One Shower (Smaller dwelling)	90L	90L	90L	90L	90L	With mixing
One Bath (Small dwelling)	120L	100L	90L	90L	90L	With stratification
One Bath (Small dwelling)	150L	100L	90L	90L	90L	With mixing
One Bath + Separate Shower (Larger dwelling)	165L	140L	130L	120L	120L	With stratification
One Bath + Separate Shower (Larger dwelling)	260L	210L	130L	130L	130L	With mixing
Two Baths (Larger dwelling)	165L	140L	130L	120L	120L	With stratification
Two Baths (Larger dwelling)	260L	210L	130L	130L	130L	With mixing

Where systems are heated by off-peak electricity, the storage capacity should be in accordance with the recommendations of the electricity supplier.

Where homes have one bathroom or shower room, the system should be able to provide adequate hot water:

- immediately after the bath has been filled, for tasks such as washing
- for a second bath after 30 minutes.

Where homes have two or more bathrooms, the system should be able to provide adequate hot water immediately after each of the baths have been filled, for tasks such as washing.

Where a shower is installed, adequate provision should be made to ensure that the outlet temperature of the water is not significantly affected by the use of other hot or cold outlets in the home. This may be achieved by the provision of a thermostatic shower mixing valve, the appropriate design of pipe sizes or dedicated supplies.

Instantaneous systems (using combination boilers) produce hot water on demand (generally at lower flow rates than storage systems), and should only be used where:

- simultaneous demand for hot water is limited. Where there are three or more outlets, the design for simultaneous discharge can omit the outlet at the kitchen sink
- storage combination boilers have the capacity as required in Table 8. Where boilers can control and prioritise hot water outputs the storage capacities can be less than the figures in Table 8 subject to manufacturer's recommendations on meeting the demand.

8.1.8.2 Locations

Storage systems weight will vary by size of storage demand designed; the installation should take into account:

- a suitable space for the siting of the storage vessel to allow for installation
- supported in accordance with manufacturer's recommendations
- installed vertically, unless designed otherwise
- accessible for maintenance, service, repair and replacement
- insulated as specified in the design.

8.1.8.3 Immersion heaters

Where an immersion heater is fitted, it should be:

- appropriate for the type of water supplied to the home
- controlled by a thermostat
- located to facilitate replacement
- supplied with an energy cut out device to prevent overheating
- suitable for the water quality being installed in
- fitted with an on/off switch.

8.1.8.4 Vented Storage systems

Vented storage system should be provided with a correctly sized expansion pipe that terminates into a correctly designed, supported and insulated supply tank.

8.1.9 Unvented storage systems

Unvented storage systems and discharge pipework shall be in accordance with relevant regulations. Be securely fixed and any discharge pipes terminate in a safe visible position. Issues to be taken into account include:

- 1) product certification
- 2) discharge pipework
- 3) low level discharge
- 4) high level discharge
- 5) discharge pipe material.

8.1.9.1 Product certification

Unvented hot water storage systems should be:

- assessed in accordance with Technical Requirement R3, or meet the requirements of BS EN 12897 and be the subject of third-party certification, (applies to both the assembled system and components)
- installed by competent installers.

8.1.9.2 Unvented storage system discharge pipework

Unvented storage discharge pipe work should:

- terminate in a safe and visible position
- have the tundish as close to the storage system as possible in a visible position
- not be connected to other waste connections
- not terminate inside garages
- be sized appropriately in line with national standards
- be adequately supported
- be installed with a fall to outside in line with the manufacturer's recommendations.

8.1.9.3 Low level discharge

Low level discharge should be:

- into a gully below the grating but above the water level. See figure 16
- onto the ground (drive, path or garden area) the pipe should discharge downwards and be no more than 100mm above ground level. The discharge should be protected against the discharge pipe being touched with fingers or hand before it has hit the ground. This is normally achieved by installing a cage over the discharge pipe. See figure 17.

Figure 16: Low level unvented discharge – trapped gully

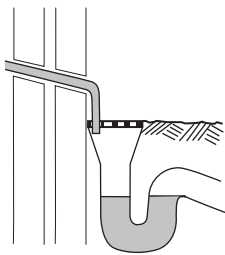
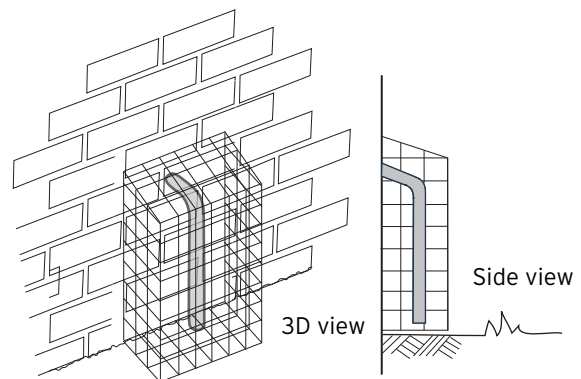

Figure 17: Low level unvented discharge – path or garden area



8.1.9.4 High level discharge

High level discharge is only acceptable when:

- it terminates onto a flat or pitched roof capable of withstanding water at high temperature
- the termination is 3m away from plastic guttering
- terminating into a metal hopper head and downpipe which in turn terminates safely at low level. Also see 8.1.9.3.

8.1.9.5 Discharge pipework material

The normal material for discharge pipework is metal.

When thermoplastic pipes or fittings or similar equipment is used compliance with R3 is required. They should have a satisfactory assessment by an appropriate independent technical approvals' authority accepted by NHBC.

Waterless traps and waste pipes should comply with the marking requirements of BS 7291-1 "Thermoplastic pipes and fittings for hot and cold water for domestic purposes".

See figure 18.

Figure 18: Unvented discharge – soil stack

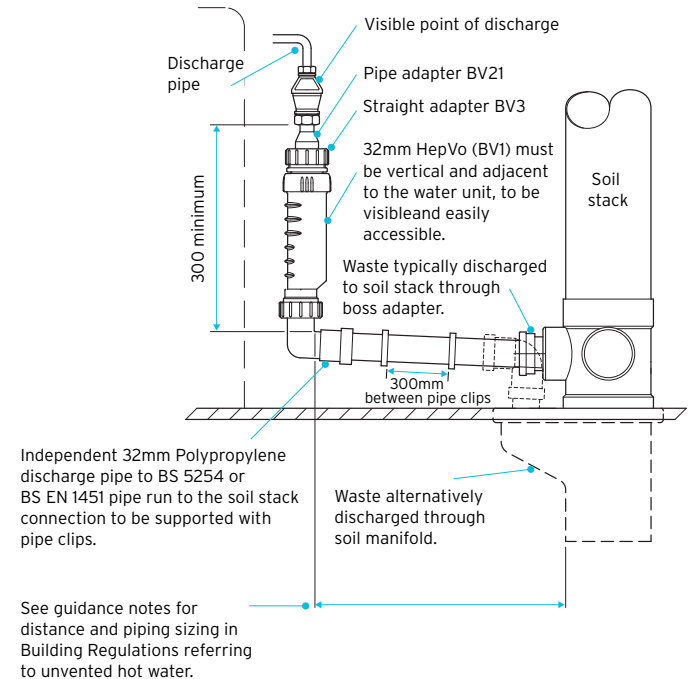

8.1.10 Soil and waste systems internal

Also see: Chapter 6.3.7

Soil and waste systems shall be in accordance with relevant Building Regulations and installed to ensure that effluent is removed without affecting health or creating unnecessary noise and smell. Items to be taken into account include:

- 1) relevant standards
- 2) air admittance valves
- 3) sound insulation to soil and vent pipe (SVP)
- 4) sanitary fittings
- 5) waste disposal
- 6) junctions.

Soil and waste systems should be:

- in accordance with the requirements of the water supplier
- adequately ventilated at the head of underground drains (this may be by a soil pipe or separate ventilation pipe)
- adequately ventilated at each branch
- arranged to ensure foul air from the drainage system cannot enter homes (eg, ventilated to 900mm above openings when within 3m)
- fixed neatly and securely to provide the correct falls
- fitted to prevent the entry of vermin.

8.1.10.1 Relevant standards

Relevant standards for domestic soil and waste systems include:

BS EN 752	Drain and sewer systems outside buildings
BS EN 12056-1	Gravity drainage systems inside buildings. General and performance requirements
BS EN 12056-2	Gravity drainage systems inside buildings. Sanitary pipework, layout and calculation
BS EN 12056-3	Gravity drainage systems inside buildings. Roof drainage, layout and calculation
BS EN 12056-4	Gravity drainage systems inside buildings. Wastewater lifting plants, layout and calculation
BS EN 12056-5	Gravity drainage systems inside buildings. Installation and testing, instructions for operation, maintenance and use

8.1.10.2 Air admittance valves should

Air admittance valves should:

- be used to allow air to enter the drainage system (but do not avoid the need to ventilate it adequately)
- comply with BS EN 12380 or be assessed in accordance with Technical Requirement R3. See figure 19
- not be positioned in areas which are liable to freezing
- have free movement of air around them which can be achieved by ventilation grilles, discreet gaps around the boxing or ventilation of the boxing into a ventilated roof void (the ventilation area should be 2500mm² minimum unless otherwise specified by the manufacturer). See figure 20
- where positioned within the home, be accessible for maintenance.

Figure 19: Air admittance valves

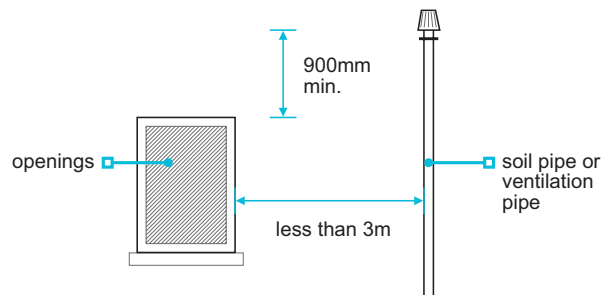

8.1.10.3 Sound insulation to soil and vent pipes

All sections of soil and vent pipe including those in bathrooms or ground floor stub stacks, should be soundproofed to limit the transmission of noise. See figure 19:

Where soil and vent pipes run horizontally through a floor void above or below a habitable room they should be:

- wrapped in at least 25mm of mineral wool (10kg/m³ min)
- adequately supported to avoid contact with the floor decking or ceiling.

Sound insulation should be provided to soil pipes passing through homes by:

- an encased boxing, using material (15kg/m²) and
- wrapping the pipe with a minimum 25mm of unfaced mineral wool (10kg/m³ min). The insulation should be continued through the thickness of each sound-insulating floor).

Soil and vent pipes which hold a satisfactory assessment by an appropriate independent technical approvals' authority acceptable to NHBC, maybe acceptable where the requirements of the Building Regulations are achieved.

Figure 20: Sound insulation to SVP

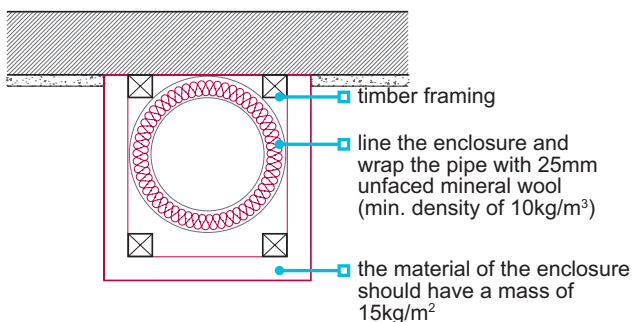

8.1.10.4 Sanitary fittings

Sanitary fittings should be:

- installed with accessories, such as chains and plugs
- secured using non-ferrous or stainless steel screws or fixings appropriate to the weight of item being secured
- fitted without using excessive packing
- fitted to ensure WC lids and seats are stable when open.

8.1.10.5 Waste disposal

Waste disposal units should be:

- provided with adequate support
- fitted with a tubular trap (not bottle or resealing)
- connected to the drainage system in accordance with the manufacturer's recommendations.

8.1.10.6 Junctions

The junctions of wall tiling with baths and showers should be made watertight using a flexible sealant to accommodate movement. The manufacturer's instructions should be followed.

Figure reference table

Figure reference table 8.1

Fig No	Title/Description	Clause	Page
Figure 1	Protection from the cold - loft space	8.1.3.4	3
Figure 2	Protection from the cold - header tanks	8.1.3.4	3
Figure 3	Pipe insulation thickness	8.1.3.4	3
Figure 4	Underfloor soil pipe insulation	8.1.3.4	3
Figure 5	Masonry brick and block plastered	8.1.5.1	5
Figure 6	Dry lined walls on batons	8.1.5.1	5
Figure 7	Dry lined walls on dabs	8.1.5.1	5
Figure 8	Timber-frame on light steel construction wall	8.1.5.1	5
Figure 9	Installed in a timber frame or light steel construction wall	8.1.5.1	5
Figure 10	Safe location of cables	8.1.6.3	7
Figure 11	Notice examples	8.1.6.4	8
Figure 12	Horizontal distance of electrical items to sinks	8.1.6.4	9
Figure 13	Horizontal distance of electrical items to hobs	8.1.6.7	9
Figure 14	Cavity tray with inset meter box	8.1.7.2	11
Figure 15	Weephole position with inset meter box	8.1.7.2	11
Figure 16	Low level unvented discharge - trapped gully	8.1.9.3	14
Figure 17	Low level unvented discharge - path or garden area	8.1.9.3	14
Figure 18	Unvented discharge - soil stack	8.1.9.5	15
Figure 19	Air admittance valves	8.1.10.2	16
Figure 20	Sound insulation to SvP	8.1.10.3	16



Chapter 8.2



Electrical generating technologies

This chapter provides guidance for outgoing utilities that generate electricity from low or zero carbon sources (LZC) for home use, storage or export, other (LZC) systems that follow the general principles of this chapter may also be acceptable, subject to specific agreement with NHBC.

This chapter contains the following sections:

- 8.2.1 solar photovoltaics (PV)
- 8.2.2 wind turbines

For figure reference tables, please go to the end of each chapter.





Chapter

8.2.1



Solar photovoltaics (PV)

Systems which convert solar radiation into electricity.

8.2.1.1	Compliance	01
8.2.1.2	Provision of information	02
8.2.1.3	System design	02
8.2.1.4	Building integration	04
8.2.1.5	Fixing	05
8.2.1.6	Access	05
8.2.1.7	Electrical installation requirements	05
8.2.1.8	Handling and storage	06
8.2.1.9	Sequence of work	06

For figure reference tables, please go to the end of each chapter.



Figure 1: Solar PV schematic

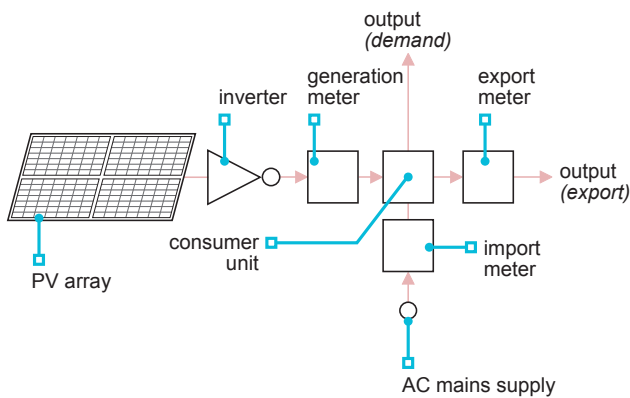
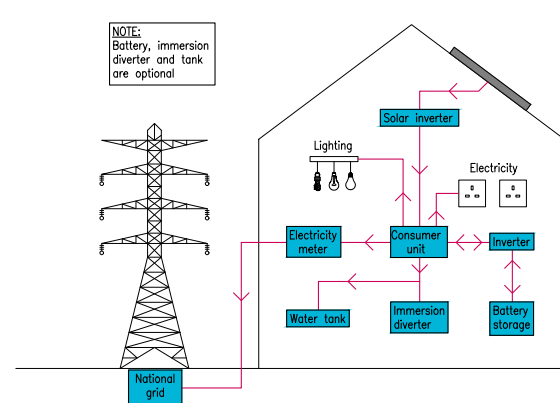

Figure 2: Solar PV schematic with battery



Definitions for solar photovoltaics (PV)

Coastal locations	A site within a distance of 500m from the general coastline of the United Kingdom
Controls	Controls are used to operate and/or regulate the system and may be electrical or mechanical
Exclusion zone	An area where entry is restricted during periods when maintenance is in progress, to prevent risk of injury or loss of life
Inverter	A device that converts direct current into alternating current
Islanding (island mode operation)	Where an LZC technology feeds the network or local distribution system during a planned or unscheduled loss of mains supply
Low or zero carbon (LZC) technologies	A term applied to renewable sources of energy, and also to technologies which are significantly more efficient than traditional solutions, or which emit less carbon in providing heating, cooling or power
Parallel electrical generation	A system in which building loads can be fed simultaneously from the national grid or electricity supply grid and on-site sources such as wind turbines and photovoltaic panels
Performance	The manner or quality of functioning for a material, product or system
Renewable energy	Energy from naturally available sources that can be replenished, including energy from the sun, the wind and tides, and from replaceable matter such as wood or other plant material
Switchgear	The combination of electrical switches, fuses and/or circuit breakers used to isolate electrical equipment

8.2.1.1 Compliance

Also see: Chapter 2.1

Solar photovoltaics (PV) shall comply with the Technical Requirements. Issues to be taken into account include:

- 1) relevant standards
- 2) product certification
- 3) operative competency.

8.2.1.1.1 Relevant standards

Solar PV should comply with relevant standards including where applicable:

BS EN 61215-1	'Terrestrial photovoltaic (PV) modules - Design qualification and type approval'
BS EN 61215-2	'Terrestrial photovoltaic (PV) modules – Test requirements'
BS EN 60068	Environmental testing of electrical equipment
BS EN IEC 61730	Requirements for testing and construction of PV
BS EN IEC 62108	Requirements for assessing the products capacity for long term operation in general open-air climates
MCS 005	On roof and integrated solar PV systems
MCS 012	The solar roof fixing standard
MCS 3002	The solar PV standard installation
MIS 3012	The MCS battery standard (Installation)

8.2.1.1.2 Product certification

Solar PV technologies should have current certification confirming satisfactory assessment by an appropriate independent authority acceptable to NHBC.

Systems, products and installations that are assessed through the Microgeneration Certification Scheme (MCS) will generally be acceptable to NHBC. Certification and test documentation should be made available to NHBC upon request.

Other certification bodies or test documentation may be acceptable where they are considered by NHBC to be a suitable alternative.

8.2.1.1.3 Operative competency

Solar PV systems should be installed by operatives:

- competent and familiar with the system being installed, and
- certified to a standard acceptable to NHBC.
- MCS Certified or

8.2.1.2 Provision of information

Designs and specifications shall be produced in a clearly understandable format, include all relevant information and be distributed to the appropriate personnel.

Provision of information is important as it allows for energy efficient use of the building and common methods adopted to prevent overheating.

Clear and fully detailed drawings should be available on site to enable work to be carried out in accordance with the design. Designs should be issued to site supervisors, relevant specialist subcontractors and suppliers, and where used include the following information:

- fixing schedule
- a full set of current drawings
- indication of which manufacturer and/or installer is responsible for each system and interface
- commissioning schedule
- manufacturers' specifications
- interface details
- on-site testing requirements
- type and spacing of clips and fixings
- type and location of ancillary components, including those used for fire safety and acoustic purposes
- commissioning certificates
- wind load calculations
- snow load calculations.

8.2.1.3 System Design

Solar PV technologies shall be designed to ensure satisfactory performance. Issues to be taken into account include:

- | | |
|------------------|-------------------------|
| 1) location | 4) performance |
| 2) system | 5) diverters |
| 3) compatibility | 6) battery and storage. |

8.2.1.3.1 Location

Solar PV systems should be correctly located, including ancillary components, and should be located and identified in accordance with the manufacturer's recommendations.

The design and location of solar PV technologies should take account of factors such as:

- orientation
- roof pitch
- coastal location
- snow loading
- shading.

When installed in a coastal location fixings and bracketry should be appropriate for the area, stainless steel grade 316 should be used where appropriate.

8.2.1.3.2 System

Solar PV technologies should be designed in accordance with the manufacturer's recommendations, certification scheme requirements and appropriate standards.

Each system should generally be supplied from one manufacturer as a package and not as individual components or materials. However, where components from more than one manufacturer are used, they should be compatible to ensure satisfactory performance.

Mixing of electrical MC4 type connections (male and female) is not acceptable unless specifically allowed by the manufacturer.

8.2.1.3.3 Compatibility

Solar PV technologies should be installed so as not to adversely affect the performance of the building to which they are fixed, and in accordance with the manufacturer's recommendations.

Multiple systems should be compatible with each other.

The temperature rating of any roof underlay should be suitable for use with Solar PV system and accessories used.

When using roof integrated solar panels ventilation must be maintained in accordance with BS 5250. Also see 7.2.15.

8.2.1.3.4 Performance

Solar PV systems designed to contribute towards space and water heating should be designed in accordance with the performance requirements in Chapter 8.1.8 and 8.3.2.

8.2.1.3.5 Diverters

The provision of Immersion diverters is discretionary, where used they should be designed by a competent person to prevent any adverse operation to the installed electrical installation either upstream or downstream including RCD and islanding protection.

8.2.1.3.6 Batteries and storage

Also see: Chapter: 8.1.6

The provision of battery storage is discretionary, where used they should be designed by a competent person and in conjunction with IET Code of Practice for Electrical Energy Storage Systems and BS 7671 18th Edition wiring regulations and:

- the installation should be in line with MIS 3012 and manufacturer's installation instructions
- the inverters must be fully type tested to the standards required by the Energy Networks Association recommendations
- the batteries and storage equipment should not be located where they are at risk of accidental damage or that their enclosures are not designed for
- batteries intended for use in dwellings should be housed in a suitable enclosure meeting the relevant IPX rating
- batteries/storage should not be placed so that escape routes are impeded, and that any fire in the battery does not compromise protected escape routes
- where batteries are located have sufficient ventilation to prevent overheating and prevent explosive conditions of evolved gasses
- should not be designed and installed where foreseeable flood or water inundation conditions may occur.

8.2.1.4 Building integration

Also see: Chapters: 7.2.15, 7.2.17 and 8.6

Solar PV technologies shall be securely fixed and not adversely affect the weather resistance of the building.

Foundations and anchor points for stand-alone LZC technologies should be designed by an engineer in accordance with Technical Requirement R5 to withstand the structural forces acting upon them.

The structure to which the LZC technology is attached should be assessed according to its ability to accept the loadings and prevent detrimental effects arising from movement or vibration.

The design of the structure should take account of:

- the self-weight of the LZC components
- imposed loads
- wind loads
- snow loads
- dynamic loading (where relevant)
- the atmospheric conditions ie, coastal locations.

Notching, drilling or chasing of structural components to accommodate service pipes or cables should either comply with Chapter 8.6 'Installation and commissioning ' or be designed by an engineer in accordance with Technical Requirement R5.

Fixings, supports, bracketry and mounting frames should:

- accommodate all static and dynamic loads in accordance with the manufacturer's recommendations
- have adequate protection against corrosion (grade 316 stainless steel is recommended for coastal locations)
- be compatible or isolated where two metals are to be joined to prevent bimetallic corrosion.

All interfaces between the LZC technology and the building should ensure adequate weather resistance (see figure 4), sealed to limit air leakage and prevent moisture from reaching the interior or any part of the structure that could be adversely affected by its presence. The envelope should be weatherproofed using appropriate flashings and fixings. Weatherproofing details that rely solely on sealant are not acceptable. Flashings should be formed from the materials listed in Table 1.

Figure 3: Solar PV types

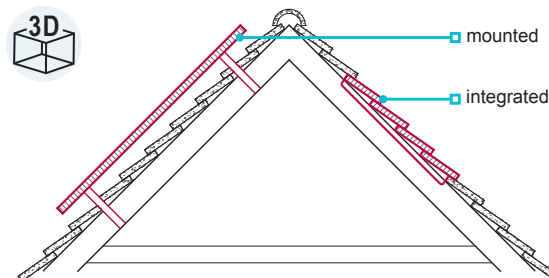

Figure 4: Solar PV fixing

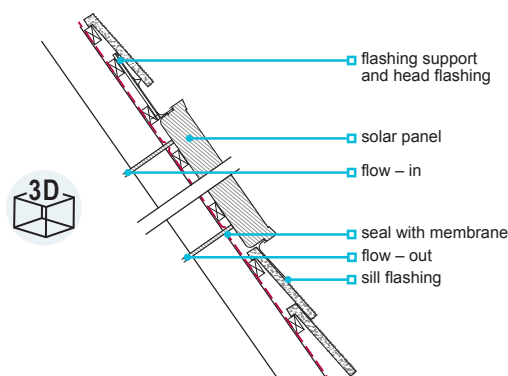

Table 1: Materials for flashings

Flashing material	Guidance
Rolled lead sheet	Minimum code 4. BS EN 12588
Aluminium and aluminium alloys	BS EN 485 and BS EN 573, 0.6-0.9mm thick and protected from contact with mortar by a coating of bituminous paint
Zinc alloys	BS EN 988 and 0.6mm thick
Copper	BS EN 1172 0.55mm thick and fully annealed. Where two metals are to be joined, they should be compatible and not cause bimetallic corrosion in that environment. Alternatively, they should be isolated from each other
Proprietary flashing, including plastic and composite.	Assessed in accordance with Technical Requirement R3

To avoid potential surface or interstitial condensation, the design should take account of thermal bridging, particularly where any part of the system, including fixings, penetrates the thermal envelope.

All installations should take into consideration rodent/bird damage, connector corrosion and potential damage caused by follow on trades.

8.2.1.5 Fixing*Also see: Chapter 2.1***Solar PV technologies shall be fixed using durable materials.**

Fixings should comply with the types listed in Table 2.

Table 2: Materials suitable for fixings

Fixing material	Guidance
Phosphor bronze	NA
Silicon bronze	NA
Stainless steel	BS EN ISO 3506
Mild steel	Coatings to BS EN ISO 2081, BS EN ISO 2082, BS EN 1461, or other appropriate treatment in accordance with BS EN ISO 12944 or BS EN ISO 14713
Aluminium alloy	BS EN 573 and BS EN 755
Stainless steel	BS EN 10088
Mild steel	BS EN 10346
Other materials	Assessed in accordance with Technical Requirement R3

Materials that comply with recognised standards, which provide equal or better performance to those above, are also acceptable.

The type, size, number, position and fitting tolerance of fixings should be in accordance with the manufacturer's recommendations.

Issues that should be taken into account include:

- the provision of suitable locking nuts and washers
- the isolation of aluminium from cementitious material.
- the isolation of dissimilar metals

All components including integrated roof trays, panels, flashings, electrical connectors and wiring that penetrate the roof structure to the space below should be appropriately flashed and comply with the requirements of R3.

8.2.1.6 Access**Appropriate arrangements shall be provided for the purposes of cleaning, inspection, maintenance and repair or replacement of solar PV technologies.**

Safe access should be provided to solar PV technologies, including switchgear, inverters, meters and controls. This is to enable the cleaning, inspection, maintenance and repair of systems. Access should be provided in accordance with the manufacturer's recommendations.

Where plant is to be installed in a loft or roof void guidance is provided in chapter 7.2.12.

8.2.1.7 Electrical installation requirements*Also see: Chapter 8.1.6***The electrical installation shall be in accordance with relevant regulations.**

Electrical installations should comply with BS 7671 'Requirements for Electrical Installations'.

Where parallel electrical generation occurs, inverters should have a relevant Engineering Recommendation G83/2 type test certificate and comply with all other parts of ER G83/2 for standard installations. Larger installations should comply with ER G59/3-2.

The electrical installation should be capable of being isolated from all other electrical sources when required, for maintenance or testing.

LZC technologies which generate electricity and are connected to the mains should automatically disconnect when there is a mains power failure. This is to prevent them from feeding the network or local distribution system during a planned or unscheduled loss of mains supply. This is known as 'islanding'.

The inclusion of any lightning protection should be installed in line with the following standards listed in Table 3.

Table 3: Lightning protection standards

BS EN 62305-1-5	Protection against lightning
PD 62305-2: 2014	Flash density map 2014. Supplement to BS EN 62305-2
BS EN IEC 62561-1	Lightning protection system components
BS EN IEC 62561-2	Lightning protection system components
IEC 60068-2-52	Environmental testing: Salt mist, cyclic (sodium chloride solution)
IECISO 6957	Copper alloys: ammonia tests for stress corrosion resistance
ISO 22479	Corrosion of metals and alloys – sulfur dioxide test in a humid atmosphere

8.2.1.8 Handling and storage

Materials, products and systems shall be handled, stored and protected in a satisfactory manner to prevent damage, distortion, weathering and degradation.

Solar PV systems should be:

- transported, lifted, handled and stored in accordance with the manufacturer’s recommendations
- delivered in sequence to avoid storage
- protected to avoid the risk of damage.

8.2.1.9 Sequence of work

Solar PV systems shall be installed in accordance with a suitable schedule.

To ensure performance, Solar PV systems and ancillary components should be installed in a logical and timely sequence in accordance with the manufacturer’s recommendations.

Figure reference table

Fig No	Title/Description	Clause	Page
Figure 1	Solar PV schematic	8.2.1	1
Figure 2	Solar PV schematic with battery	8.2.1	1
Figure 3	Solar PV types	8.2.1.4	4
Figure 4	Solar PV fixing	8.2.1.4	4



Chapter

8.2.2



Wind turbines

Systems which convert wind into electricity.

8.2.2.1	Compliance	09
8.2.2.2	Provision of information	10
8.2.2.3	System design	10
8.2.2.4	Building integration	12
8.2.2.5	Fixing	12
8.2.2.6	Access	13
8.2.2.7	Electrical installation requirements	13
8.2.2.8	Handling and storage	13
8.2.2.9	Sequence of work	13

For figure reference tables, please go to the end of each chapter.



Figure 1: Wind turbine schematic

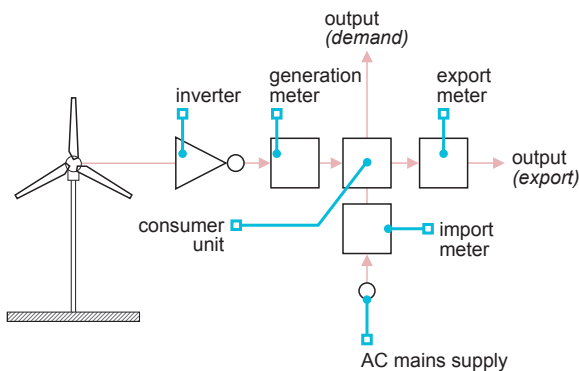
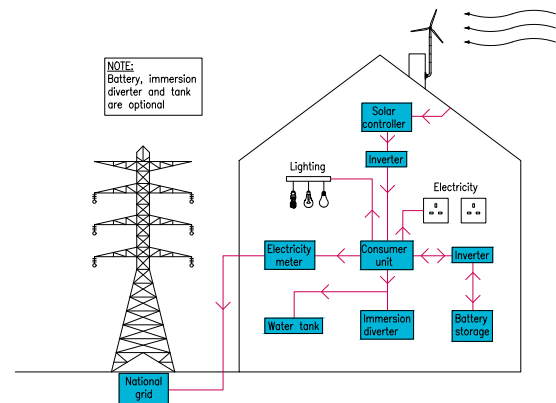

Figure 2: Wind turbine schematic with battery



Definitions for wind turbines

Coastal locations	A site within a distance of 500m from the general coastline of the United Kingdom
Controls	Controls are used to operate and/or regulate the system and may be electrical or mechanical
Exclusion zone	An area where entry is restricted during periods when maintenance is in progress, to prevent risk of injury or loss of life
Inverter	A device that converts direct current into alternating current
Islanding (island mode operation)	Where an LZC technology feeds the network or local distribution system during a planned or unscheduled loss of mains supply
Low or zero carbon (LZC) technologies	A term applied to renewable sources of energy, and also to technologies which are significantly more efficient than traditional solutions, or which emit less carbon in providing heating, cooling or power
Parallel electrical generation	A system in which building loads can be fed simultaneously from the national grid or electricity supply grid and on-site sources such as wind turbines and photovoltaic panels
Performance	The manner or quality of functioning for a material, product or system
Renewable energy	Energy from naturally available sources that can be replenished, including energy from the sun, the wind and tides, and from replaceable matter such as wood or other plant material
Switchgear	The combination of electrical switches, fuses and/or circuit breakers used to isolate electrical equipment

8.2.2.1 Compliance

Also see: Chapter 2.1

Wind turbines shall comply with the Technical Requirements. And shall be securely fixed and not adversely affect the weather resistance of the building.

- 1) relevant standards
- 2) product certification
- 3) operative competency.

8.2.2.1.1 Relevant standards

Wind turbines should comply with relevant standards including where applicable:

BS EN 61400-1	'Wind turbines'
BS EN 61400-2	'Wind turbines. Small wind turbines'
BS EN 61400-11	"Wind turbines acoustic noise measurement techniques"
BS EN 61400-12	"Power performance measurements of electricity producing wind turbines"
BS EN 60068	Environmental testing of electrical equipment
BS EN IEC 62108	Requirements for assessing the products capacity for long term operation in general open-air climates
MIS 3003	MCS requirements for the supply, design and installation of micro and small wind turbine systems
MCS 006	Micro and small wind turbines

8.2.2.1.2 Product certification

Wind turbine technologies should have current certification confirming satisfactory assessment by an appropriate independent authority acceptable to NHBC.

Systems, products and installations that are assessed through the Microgeneration Certification Scheme (MCS) will generally be acceptable to NHBC. Certification and test documentation should be made available to NHBC upon request.

Other certification bodies or test documentation may be acceptable where they are considered by NHBC to be a suitable alternative.

8.2.2.1.3 Operative competency

Wind turbine systems should be installed by operatives:

- competent and familiar with the system being installed, and
- certified to a standard acceptable to NHBC.
- MCS Certified or

8.2.2.2 Provision of information

Designs and specifications shall be produced in a clearly understandable format, include all relevant information and be distributed to the appropriate personnel.

Provision of information is important as it allows for energy efficient use of the building and common methods adopted to prevent overheating.

Clear and fully detailed drawings should be available on site to enable work to be carried out in accordance with the design. Designs should be issued to site supervisors, relevant specialist subcontractors and suppliers, and where used include the following information:

- fixing schedule
- a full set of current drawings
- indication of which manufacturer and/or installer is responsible for each system and interface
- commissioning schedule
- manufacturers' specifications
- interface details
- on-site testing requirements
- type and spacing of clips and fixings
- type and location of ancillary components, including those used for fire safety and acoustic purposes
- commissioning certificates
- wind load calculations
- snow load calculations.

8.2.2.3 System design

Wind turbine systems shall be designed to ensure satisfactory performance. Issues to be taken into account include:

- 1) location
- 2) system
- 3) compatibility
- 4) performance
- 5) inverters
- 6) battery and storage
- 7) acoustics.

8.2.2.3.1 Location

Wind turbine systems including ancillary equipment should be correctly located and:

- installed in accordance with the manufacturer's instructions and MIS 3003
- not be obstructed to prevent incorrect and efficient operation
- for stand-alone wind turbine systems, suitable exclusion zones should be provided in accordance with the manufacturer's recommendations and geographical location.

The design and location of wind turbine technologies should take account of factors such as:

- coastal location.

When installed in a coastal location fixings and bracketry should be appropriate for the area, stainless steel grade 316 should be used where appropriate.

8.2.2.3.2 System

Wind turbine systems should be designed in accordance with the manufacturer's recommendations, certification scheme requirements and appropriate standards.

Each system should generally be supplied from one manufacturer as a package and not as individual components or materials. However, where components from more than one manufacturer are used, they should be compatible to ensure satisfactory performance.

8.2.2.3.3 Compatibility

Wind turbine systems should be installed so as not to adversely affect the performance of the building to which they are fixed, and accordance with the manufacturer's recommendations.

Multiple systems should be compatible with each other.

8.2.2.3.4 Performance

Wind turbine systems designed to contribute towards water heating should be designed in accordance with the performance requirements in Chapter 8.1.8.

8.2.2.3.5 Diverters

The provision of Immersion diverters is discretionary, where used they should be designed by a competent person to prevent any adverse operation to the installed electrical installation either upstream or downstream including RCD and islanding protection.

8.2.2.3.6 Batteries and storage

Also see: Chapter: 8.1.6

The provision of battery storage is discretionary, where used they should be designed by a competent person and in conjunction with IET Code of Practice for Electrical Energy Storage Systems and BS 7671 18th Edition wiring regulations and:

- the installation should be in line with MIS 3012 and manufacturer's installation instructions
- the inverters must be fully type tested to the standards required by the Energy Networks Association recommendations
- the batteries and storage equipment should not be located where they are at risk of accidental damage or that their enclosures are not designed for
- batteries intended for use in dwellings should be housed in a suitable enclosure meeting the relevant IPX rating
- batteries/storage should not be placed so that escape routes are impeded, and that any fire in the battery does not compromise protected escape routes
- where batteries are located have sufficient ventilation to prevent overheating and prevent explosive conditions of evolved gasses
- should not be designed and installed where foreseeable flood or water inundation conditions may occur.

8.2.2.3.7 Acoustics

Design and location should take account of:

- internal and external noise
- vibration
- the effect on neighbouring properties, particularly the positioning of the wind turbine system in relation to openings.

8.2.2.4 Building integration

Also see: Chapter 8.6

Wind turbine systems shall be securely fixed and not adversely affect the weather resistance of the building.

Foundations and anchor points for stand-alone LZC technologies should be designed by an engineer in accordance with Technical Requirement R5 to withstand the structural forces acting upon them.

The structure to which the LZC technology is attached should be assessed according to its ability to accept the loadings and prevent detrimental effects arising from movement or vibration.

The design of the structure should take account of:

- the self-weight of the LZC components
- imposed loads
- wind loads
- snow loads
- dynamic loading (where relevant).

Notching, drilling or chasing of structural components to accommodate service pipes or cables should either comply with Chapter 8.6 or be designed by an engineer in accordance with Technical Requirement R5.

Fixings, supports, bracketry and mounting frames should:

- accommodate all static and dynamic loads in accordance with the manufacturer's recommendations
- have adequate protection against corrosion (grade 316 stainless steel is recommended for coastal locations)
- be compatible or isolated where two metals are to be joined to prevent bimetallic corrosion.

Aluminium and aluminium alloys should not come into contact with cementitious material.

All interfaces between the LZC technology and the building should ensure adequate weather resistance, sealed to limit air leakage and prevent moisture from reaching the interior or any part of the structure that could be adversely affected by its presence. The envelope should be weatherproofed using appropriate flashings and fixings. Weatherproofing details that rely solely on sealant are not acceptable.

8.2.2.5 Fixing

Also see: Chapter 2.1

Wind turbine systems shall be fixed using durable materials.

Fixings should comply with the types listed in Table 1.

Table 1: Materials suitable for fixings

Fixing material	Guidance
Phosphor bronze	NA
Silicon bronze	NA
Stainless steel	BS EN ISO 3506
Mild steel	Coatings to BS EN ISO 2081, BS EN ISO 2082, BS EN 1461, or other appropriate treatment in accordance with BS EN ISO 12944 or BS EN ISO 14713
Aluminum alloy	BS EN 573 and BS EN 755
Stainless steel	BS EN 10088
Mild steel	BS EN 10346
Other materials	Assessed in accordance with Technical Requirement R3

Materials that comply with recognised standards, which provide equal or better performance to those above, are also acceptable.

The type, size, number, position and fitting tolerance of fixings should be in accordance with the manufacturer's recommendations.

Issues that should be taken into account include:

- the provision of suitable locking nuts and washers
- the isolation of aluminium from cementitious material.
- the isolation of dissimilar metals

8.2.2.6 Access

Appropriate arrangements shall be provided for the purposes of cleaning, inspection, maintenance, and repair or replacement of wind turbine systems.

Safe access should be provided to the wind turbine systems, including switchgear, inverters, meters and controls. This is to enable the cleaning, inspection, maintenance and repair of systems. Access should be provided in accordance with the manufacturer's recommendations.

8.2.2.7 Electrical installation requirements

Also see: Chapter: 8.1.6

The electrical installation shall be in accordance with relevant regulations.

Electrical installations should comply with BS 7671 'Requirements for Electrical Installations'.

Where parallel electrical generation occurs, inverters should have a relevant Engineering Recommendation G83/2 type test certificate and comply with all other parts of ER G83/2 for standard installations. Larger installations should comply with ER G59/3-2.

The electrical installation should be capable of being isolated from all other electrical sources when required, for maintenance or testing.

Wind turbine systems which generate electricity and are connected to the mains should automatically disconnect when there is a mains power failure. This is to prevent them from feeding the network or local distribution system during a planned or unscheduled loss of mains supply. This is known as 'islanding'.

The inclusion of any lightning protection must be installed as directed by the equipment manufacturer.

8.2.2.8 Handling and storage

Materials, products, and systems shall be handled, stored and protected in a satisfactory manner to prevent damage, distortion, weathering and degradation.

Wind turbine systems should be:

- transported, lifted, handled and stored in accordance with the manufacturer's recommendations
- delivered in sequence to avoid storage
- protected to avoid the risk of damage.

8.2.2.9 Sequence of work

Wind turbine systems shall be installed in accordance with a suitable schedule.

To ensure performance, wind turbine systems and ancillary components should be installed in a logical and timely sequence in accordance with the manufacturer's recommendations.

Figure reference table

Figure reference table 8.2.2

Fig No	Title/Description	Clause	Page
Figure 1	Wind turbine schematic	8.2.2	9
Figure 2	Wind turbine schematic with battery	8.2.2	9



Chapter 8.3



Space heating systems

This chapter provides guidance for space heating design and equipment that provide heating solutions including low or zero carbon sources (LZC), other (LZC) systems that follow the general principles of this chapter may also be acceptable, subject to specific agreement with NHBC.

This chapter contains the following sections:

- space heating
- gas heating
- heat pumps
- biomass

For figure reference tables, please go to the end of each chapter.





Chapter

8.3.1



NHBC

Space heating

Space heating relates to the design of home heating to achieve comfort conditions.

8.3.1.1 Requirements

01



8.3.1.1 Requirements

Also see: Chapter 2.1

When space heating is provided, it shall comply with the Technical Requirements and ensure safe operation. Issues to be taken into account include:

1) relevant standards

2) provision of heating

8.3.1.1.1 Relevant standards

Relevant standards for space heating design used in domestic hydronic systems include:

BS 5410	'Code of practice for oil firing'
BS EN 14336	Heating systems in buildings. Installation and commissioning of water based heating systems
BS 8303	'Installation of domestic heating and cooking appliances burning solid mineral fuels'
BS EN 12828	'Heating systems in buildings. Design for water-based heating systems'
BSRIA guide BG 4/2011	'Underfloor heating and cooling'
CIBSE guide A	Environmental design
CIBSE	Domestic heating design guide

Space heating and cooling appliances, including all components and controls, should be of a type approved by the relevant authority, including:

- gas appliances – Assessment by an appropriate independent technical approvals' authority accepted by NHBC confirming compliance with UK CA, UK NI or CE marking
- solid fuel – Solid Fuel Association, Heating Equipment Testing & Approval Scheme
- electricity – British Electrotechnical Approvals Board
- oil – OFTEC
- LZC technologies – should have a current certificate confirming satisfactory assessment by an appropriate independent authority acceptable to NHBC. Systems, products and installations assessed through Microgeneration Certification Scheme (MCS) will generally be acceptable to NHBC
- certification and test documentation should be made available to NHBC upon request
- other certification bodies or test documentation may be acceptable where they are considered by NHBC to be a suitable alternative.

8.3.1.1.2 Space heating provision

The provision of whole home or central heating is discretionary. Where provided by Infrared radiant panels the system should be designed by a specialist and recognised standards, where provided by hydronic systems or convector panel heaters, it should be designed in accordance with Tables 1,2 and 3, recognised standards, and:

- the number of air changes per hour from kitchens and bathrooms should account for any mechanical ventilation
- where rooms contain open flued appliances, the rate of air change used for the design should be increased in accordance with BS EN 12831
- room ventilation rates should be in accordance with recognised standards and guidance eg, CIBSE domestic heating design guide or other approved by NHBC see table 1
- design temperatures should be verified by calculations and not by performance tests
- the main living room should have a heating appliance or a heat output as part of a whole home heating system
- heat loss calculations should be based on external temperature in line with tables 2 and 3
- the heating designs must include allowances where applicable for thermal bridging
- the design may need to use elevated temperatures to take into account frail, elderly or the infirm.

Table 1: Ventilation rates per hour (CIBSE Domestic heating design guide)

Room	ACH	Room	ACH	Room	ACH
Lounge/sitting room	0.5	Cloakroom/WC	1.5*	Internal room or corridor	0.0
Living room	0.5	Toilet	1.5*	Bedroom/study	0.5
Breakfast room	0.5	Utility room	0.5*	Landing	0.5
Dining room	0.5	Study	0.5	Bathroom	0.5*
Kitchen	0.5*	Games room	0.5	Shower room	0.5*
Family/breakfast room	0.5*	Bedroom	0.5	Dressing room	0.5
Hall	0.5	Bedroom with ensuite	1.0	Storeroom	0.5

* where mechanical extract ventilation is to be installed and the value exceeds the natural infiltration then due allowance must be made for the air extracted from any connecting room or corridor as detailed in Approved Document F.

Table 2: Room temperatures, new build insulated to current standards

Room	Temp °C	Room	Temp °C	Room	Temp °C
Lounge/sitting room	21	Cloakroom/WC	21	Internal room or corridor	21
Living room	21	Toilet	21	Bedroom/study	21
Breakfast room	21	Utility room	21	Landing	21
Dining room	21	Study	21	Bathroom	22
Kitchen	21	Games room	21	Shower room	22
Family/breakfast room	21	Bedroom	21	Dressing room	21
Hall	21	Bedroom with en suite	21	Storeroom	21

Table 3: Outdoor design temperatures

Region	Latitude	Outdoor design temperature °C	Ground reference temperature (winter mean °C)
Scotland & Isles	56-60°N	-5	+5.5
Northern England & Northern Ireland	54-56°N	-4	+6.0
Midlands, Wales and ROI	52-54°N	-3	+6.5
London, SW England	51-52°N	-2	+7.0
Southern England	50-51°N	-1	+7.5



Chapter

8.3.2



Gas heating appliances

Also see: Chapter 6.8

Appliances using natural gas or LPG to provide space heating and water to a dwelling.

8.3.2.1	Compliance	05
8.3.2.2	Provision of information	05
8.3.2.3	System design	06
8.3.2.4	Building integration	06
8.3.2.5	Fixing	07
8.3.2.6	Access	07
8.3.2.7	Electrical installation requirements	07
8.3.2.8	Handling and storage	07
8.3.2.9	Sequence of work	07



8.3.2.1 Compliance

Also see: Chapter 2.1

Gas heating appliances shall comply with the Technical Requirements. Issues to be taken into account include:

- 1) relevant standards
- 2) product certification
- 3) operative competency.

8.3.2.1.1 Relevant standards

Gas heating appliances should comply with relevant standards including where applicable:

BS 6798	Specification for selection, installation, inspection, commissioning, servicing and maintenance of gas-fired boilers of rated input not exceeding 70 kW net
BS 5440 Part 1	Flueing and ventilation for gas appliances of rated input not exceeding 70kW - flueing
BS 5440 Part 2	Flueing and ventilation for gas appliances of rated input not exceeding 70kW - ventilation

8.3.2.1.2 Product certification

Gas heating appliances should hold a current assessment by an appropriate independent technical approvals' authority accepted by NHBC confirming compliance with UK CA, UK NI or CE marking:

- declaration of Conformity detailing the standards the product complies with
- documents to be available on request.

8.3.2.1.3 Operative competency

Gas heating appliances and associated equipment shall be installed by competent operatives:

- competent and familiar with the system being installed, and
- member of a class of persons approved by the HSE (Gas Safe Registered).

8.3.3.2 Provision of information

Designs and specifications shall be produced in a clearly understandable format, include all relevant information and be distributed to the appropriate personnel.

Provision of information is important as it allows for energy efficient use of the building and common methods adopted to prevent overheating.

Clear and fully detailed drawings should be available on site to enable work to be carried out in accordance with the design. Designs should be issued to site supervisors, relevant specialist subcontractors and suppliers, and where used include the following information:

- fixing schedule
- a full set of current drawings
- indication of which manufacturer and/or installer is responsible for each system and interface
- commissioning schedule
- manufacturers' specifications
- interface details
- on-site testing requirements
- type and spacing of clips and fixings
- type and location of ancillary components, including those used for fire safety and acoustic purposes
- commissioning certificates
- central heating pipe runs
- underfloor heating pipe runs
- specification for controls.

8.3.2.3 System design

Gas heating systems shall be designed to ensure satisfactory performance. Issues to be taken into account include:

- | | |
|------------------|----------------|
| 1) location | 4) performance |
| 2) system | 5) acoustics. |
| 3) compatibility | |

8.3.2.3.1 Location

Gas heating appliances, including ancillary components should be located and identified in accordance with the manufacturer's recommendations. Consideration should be given to :

- coastal locations (see 8.2.1 definitions)
- height of building and flue materials.

8.3.2.3.2 System

Gas heating systems should be designed in accordance with the manufacturer's recommendations and appropriate standards.

Each system incorporating a flue should generally be supplied from one manufacturer as a package and not as individual components or materials. However, where components from more than one manufacturer are used, they should be compatible to ensure satisfactory performance.

8.3.2.3.3 Compatibility

Gas heating systems should be installed so as not to adversely affect the performance of the building to which they are fixed, and accordance with the manufacturer's recommendations.

8.3.2.3.4 Performance

Gas heating systems designed to contribute towards space and water heating should be designed in accordance with the performance requirements in Chapter 8.4 and 8.6.

8.3.2.3.5 Acoustics

Design and location should take account of:

- internal and external noise
- vibration.

8.3.2.4 Building integration

Also see: Chapter 8.6

Gas heating appliance systems installation shall be securely fixed and not adversely affect the weather resistance of the building.

Notching, drilling or chasing of structural components to accommodate service pipes or cables should either comply with Chapter 8.7.1 or be designed by an engineer in accordance with Technical Requirement R5.

Fixings, supports, bracketry and mounting frames should:

- accommodate all static and dynamic loads in accordance with the manufacturer's recommendations
- have adequate protection against corrosion (grade 316 stainless steel is recommended for coastal locations)
- be compatible or isolated where two metals are to be joined to prevent bimetallic corrosion.

Aluminium and aluminium alloys should not come into contact with cementitious material.

All interfaces between the building and equipment should ensure adequate weather resistance, sealed to limit air leakage and prevent moisture from reaching the interior or any part of the structure that could be adversely affected by its presence. The envelope should be weatherproofed using appropriate flashings and fixings. Weatherproofing details that rely solely on sealant are not acceptable.

8.3.2.5 Fixing

Also see: Chapter 2.1

Gas heating systems shall be securely fixed using durable materials.

Fixings should comply with the types listed in Table 1.

Table 1: Materials suitable for fixings

Fixing material	Guidance
Phosphor bronze	NA
Silicon bronze	NA
Stainless steel	BS EN ISO 3506
Mild steel	Coatings to BS EN ISO 2081, BS EN ISO 2082, BS EN 1461, or other appropriate treatment in accordance with BS EN ISO 12944 or BS EN ISO 14713
Aluminum alloy	BS EN 573 and BS EN 755
Stainless steel	BS EN 10088
Mild steel	BS EN 10346
Other materials	Assessed in accordance with Technical Requirement R3

Materials that comply with recognised standards, which provide equal or better performance to those above, are also acceptable.

The type, size, number, position and fitting tolerance of fixings should be in accordance with the manufacturer's recommendations.

Issues that should be taken into account include:

- the provision of suitable locking nuts and washers
- the isolation of aluminium from cementitious material.
- the isolation of dissimilar metals

8.3.2.6 Access

Appropriate arrangements shall be provided for the purposes of cleaning, inspection, maintenance, and repair or replacement of gas heating systems.

Safe access should be provided to systems, to enable the cleaning, inspection, maintenance, and repair or replacement. Access should be provided in accordance with the manufacturer's recommendations.

When installed in a loft or roof void guidance is provided in chapter 7.2.12.

8.3.2.7 Electrical installation requirements

Also see: Chapter: 8.1.6

The electrical installation shall be in accordance with relevant regulations.

Electrical installations should comply with BS 7671 'Requirements for Electrical Installations'.

The electrical installation should be capable of being isolated from all other electrical sources when required, for maintenance or testing. An unswitched shuttered socket or double pole fused spur with 3.5mm separation will generally be acceptable.

8.3.2.8 Handling and storage

Materials, products, and systems shall be handled, stored and protected in a satisfactory manner to prevent damage, distortion, weathering and degradation.

Gas heating systems should be:

- transported, lifted, handled and stored in accordance with the manufacturer's recommendations
- delivered in sequence to avoid storage
- protected to avoid the risk of damage.

8.3.2.9 Sequence of work

Gas heating systems shall be installed in accordance with a suitable schedule.

To ensure performance, gas heating systems and ancillary components should be installed in a logical and timely sequence in accordance with the manufacturer's recommendations.



Chapter

8.3.3



Heat pumps

Systems which transfer heat from low energy sources.

8.3.3.1	Compliance	10
8.3.3.2	Provision of information	11
8.3.3.3	System design	11
8.3.3.4	Pipes insulation and protection from cold	12
8.3.3.5	Ground collectors	13
8.3.3.6	Building integration	13
8.3.3.7	Fixing	13
8.3.3.8	Access	14
8.3.3.9	Electrical installation requirements	14
8.3.3.10	Handling and storage	14
8.3.3.11	Sequence of work	14

For figure reference tables, please go to the end of each chapter.



The most common sources are ground, outdoor air, and exhaust air. See figure 1 to 4.

Figure 1: Heat pump schematic

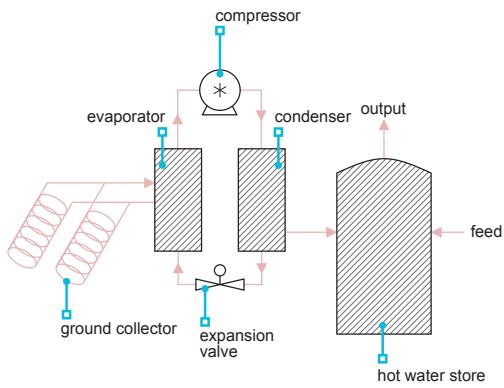

Figure 2: Air source heat pump

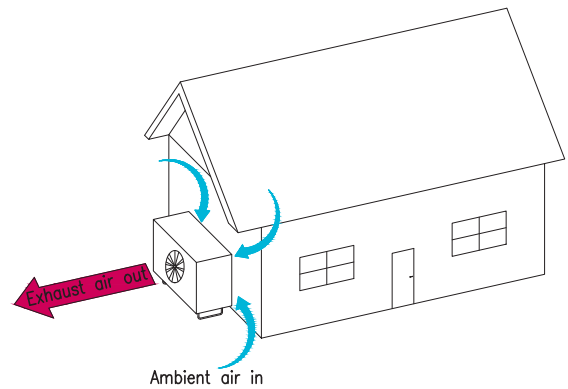

Figure 3: Ground source heat pump

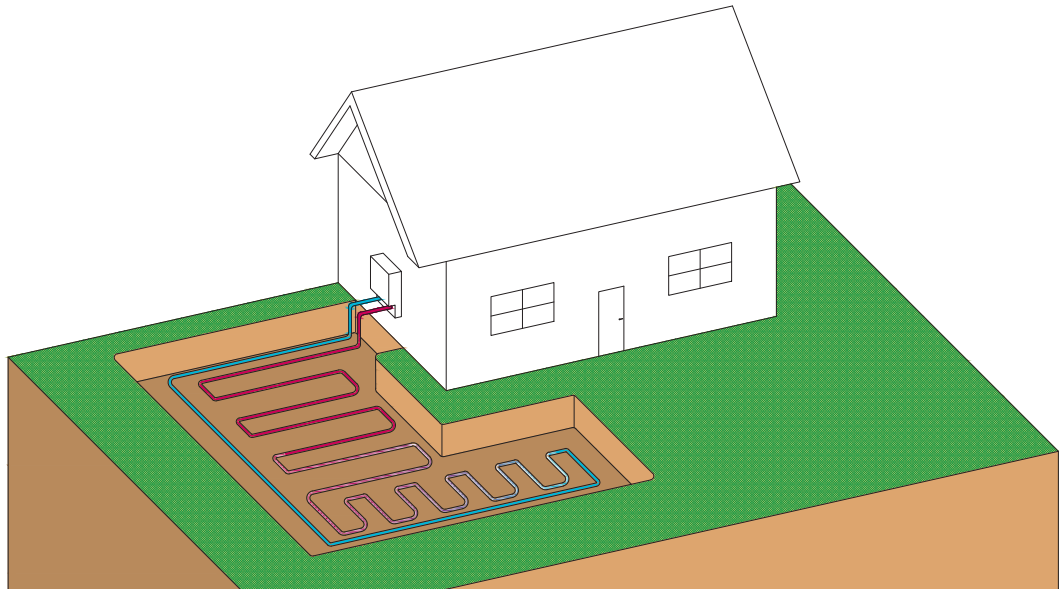
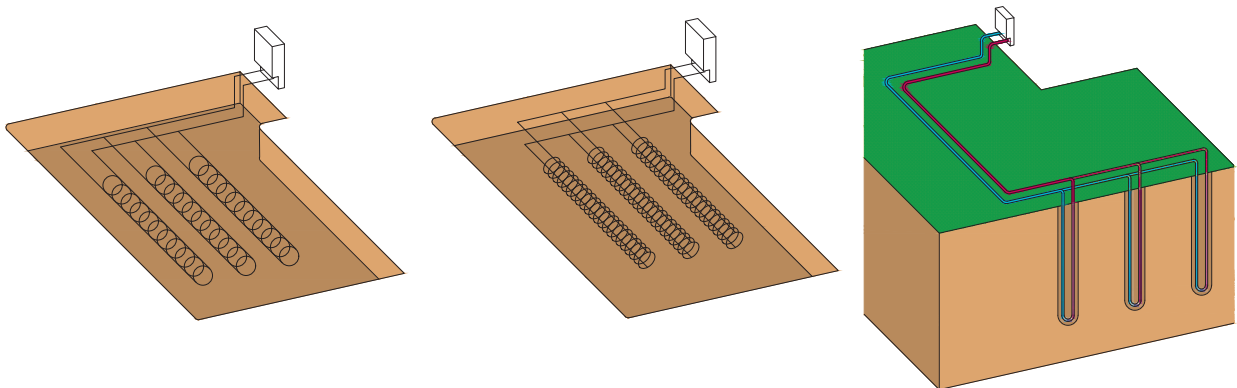

Figure 4: Alternative heat sources (boreholes and slinkys)



Definitions for heat pumps

Coastal locations	A site within a distance of 500m from the general coastline of the United Kingdom
Controls	Controls are used to operate and/or regulate the system and may be electrical or mechanical
Exclusion zone	An area where entry is restricted during periods when maintenance is in progress, to prevent risk of injury or loss of life
Exhaust air heat pump	A subset of air-source heat pumps, exhaust-air heat pumps are typically combined with mechanical ventilation to extract and reuse heat from the exhaust air
Ground collectors	The component of a ground source heat pump system which absorbs heat from the ground. Collectors can be installed either horizontally or vertically in the ground. They may also be incorporated into proprietary foundation systems
Low or zero carbon (LZC) technologies	A term applied to renewable sources of energy, and also to technologies which are significantly more efficient than traditional solutions, or which emit less carbon in providing heating, cooling or power
Monobloc heat pump	A type of heat pump in which all of its components are in one unit; in the case of air-source heat pumps, this will usually be located outside the dwelling
Open loop system	A heat pump system that extracts water from an underground source, pumps it through a heat exchanger and returns it underground
Performance	The manner or quality of functioning for a material, product or system
Refrigerant pipework	Carries refrigerant between the indoor and outdoor unit of a split system. Normally made of copper and must be insulated and protected from damage
Renewable energy	Energy from naturally available sources that can be replenished, including energy from the sun, the wind and tides, and from replaceable matter such as wood or other plant material
Split system heat pump	A type of heat pump in which the condenser is located indoors, the evaporator is located outdoors, and the two are linked by refrigerant pipework
Switchgear	The combination of electrical switches, fuses and/or circuit breakers used to isolate electrical equipment

8.3.3.1 Compliance

Also see: Chapter 2.1

Heat pumps shall comply with the Technical Requirements. Issues to be taken into account include:

- 1) relevant standards
- 2) product certification
- 3) operative competency.

8.3.3.1.1 Relevant standards

Heat pumps should comply with relevant standards including where applicable:

BS EN 14511-1	'Air conditioners, liquid chilling packages and heat pumps for space heating and cooling with electrically driven compressors for space heating and cooling'. Terms and definitions
BS EN 14511-2	'Air conditioners, liquid chilling packages and heat pumps for space heating and cooling with electrically driven compressors for space heating and cooling'. Test conditions
BS EN 14511-3	'Air conditioners, liquid chilling packages and heat pumps for space heating and cooling with electrically driven compressors for space heating and cooling'. Test methods
BS EN 14511-4	'Air conditioners, liquid chilling packages and heat pumps for space heating and cooling with electrically driven compressors for space heating and cooling'. Requirements
BS EN 16147	Heat pumps with electrically driven compressors requirements for domestic hot water
BS EN 12102-1	Determining the sound power level of compressors
BS EN 14825	Calculation of seasonal performance
BS EN IEC 62108	Requirements for assessing the products capacity for long term operation in general open-air climates
MIS 3005- d	Microgeneration Certification Scheme requirements for the supply, design of heat pump systems
MIS 3005 - i	Microgeneration Installation Standard for heat pumps installation
Fluorinated gas (F) Gas	Guidance for users, producers and traders of HFCs, PFCs and SF6
CC 002	Micro generation heat pump compliance certificate (commissioning standard)
MCS 007	Heat pump standard

8.3.3.1.2 Product certification

Heat pump technologies should have current certification confirming satisfactory assessment by an appropriate independent authority acceptable to NHBC.

Systems, products and installations that are assessed through the Microgeneration Certification Scheme (MCS) will generally be acceptable to NHBC. Certification and test documentation should be made available to NHBC upon request.

Other certification bodies or test documentation may be acceptable where they are considered by NHBC to be a suitable alternative.

8.3.3.1.3 Operative competency

Heat pump systems should be installed by operatives:

- competent and familiar with the system being installed, and
- certified to a standard acceptable to NHBC.
- MCS certified or

Where installers are not MCS accredited they should still hold the relevant qualifications:

- completed an approved British Plumbing Employers Council (BPEC) training course for Heat Pump Systems and Low temperature hot water heating systems
- electrically qualified
- F Gas registered
- registered to install unvented cylinders.

8.3.3.2 Provision of information

Designs and specifications shall be produced in a clearly understandable format, include all relevant information and be distributed to the appropriate personnel.

Provision of information is important as it allows for energy efficient use of the building and common methods adopted to prevent overheating.

Clear and fully detailed drawings should be available on site to enable work to be carried out in accordance with the design. Designs should be issued to site supervisors, relevant specialist subcontractors and suppliers, and where used include the following information:

- fixing schedule
- a full set of current drawings
- indication of which manufacturer and/or installer is responsible for each system and interface.
- commissioning schedule
- manufacturers' specifications
- interface details
- on-site testing requirements
- type and spacing of clips and fixings
- type and location of ancillary components, including those used for fire safety and acoustic purposes
- commissioning certificates
- central heating pipe runs
- underfloor heating pipe runs
- specification for controls.

8.3.3.3 System design

Also see: Chapter 8.3.1

Heat pumps systems shall be designed to ensure satisfactory performance. Issues to be taken into account include:

- 1) location
- 2) system design
- 3) compatibility
- 4) performance
- 5) acoustics.

8.3.3.3.1 Location

Heat pumps, including ancillary components should be located and identified in accordance with the manufacturer's recommendations.

Heat pumps when sited in coastal locations should be suitable for the environment. Manufacturers recommendations should be followed detailing maintenance requirements, or any ancillary coatings that are acceptable if not factory treated, to prolong the life of the heat pump.

8.3.3.3.2 System design

Heat pump systems should be designed in accordance with the manufacturer's recommendations, certification scheme requirements and appropriate standards.

Each system should generally be supplied from one manufacturer as a package and not as individual components or materials. However, where components from more than one manufacturer are used, they should be compatible to ensure satisfactory performance.

The heat pump selected should provide not less than 100% of the calculated design space heating power requirement at the winter design condition and include any energy required for defrost cycles. Any supplementary electric heating shall only operate when the conditions are outside of the standards.

- all heat loss calculations should be in accordance with recognised standards and guidance, eg CIBSE Domestic Heating Design Guide or other approved by NHBC
- fabric heat loss calculations to be based on the building design and thermal conductivity of the materials from which the element is constructed
- the heating designs must include allowances where applicable for thermal bridging
- design mean water temperature (MWT) of 42.5°C, the design can utilise a (MWT) lower than this
- the number and sizing of heat emitters eg radiators or size of underfloor system must be sized to the design mean water temperature (MWT)
- the system pipework or underfloor heating must be sized to the design mean water temperature (MWT)
- the heat pump must have a minimum coefficient of performance of 3.0 for space heating
- the heat pump must have a minimum Seasonal Coefficient of Performance of 2.7
- the heat pump must control the pump operation
- the heat pump must control any outdoor fan operation
- the heat pump must control the defrost cycle for the external air side
- weather compensation or internal temperature control must be adopted with all heat pumps
- where the dwelling contains other heat sources all control should be done from a singular control unit.

8.3.3.3.3 Compatibility

Heat pump systems should be installed so as not to adversely affect the performance of the building to which they are fixed, and in accordance with the manufacturer's recommendations.

Multiple systems should be compatible with each other.

8.3.3.3.4 Performance

Heat pump systems designed to contribute towards space and water heating should be designed in accordance with the performance requirements in Chapter 8.1 and 8.3.

8.3.3.3.5 Acoustics

Design and location should take account of:

- internal and external noise
- vibration
- the effect on neighbouring properties, particularly the positioning of the heat pump in relation to openings.

8.3.3.4 Pipes, insulation and protection from cold

Also see: Chapter 8.6

All pipework and insulation, including refrigerant pipework, shall ensure adequate performance and be designed to prevent freezing.

Materials used for pipes and insulation should be suitable for the intended purpose and provide satisfactory performance for the life of the system. Pipes should comply with relevant codes and standards or be independently assessed for their intended use in accordance with Technical Requirement R3. Insulation materials should be inert, and durable, and should not be adversely affected by moisture or vapour. They should also comply with relevant codes and standards or be independently assessed for their intended use in accordance with Technical Requirement R3.

Where there is a risk of pipes freezing, they should be insulated, particularly when at, or close to, ground level.

Refrigerant pipework connecting split systems should be of refrigerant quality copper pipe or other material as recommended by the manufacturer. The pipe should be insulated, and the insulation should incorporate a vapour control layer to prevent ice build-up.

Air source systems should incorporate an automatic defrost cycle and suitable condensate drainage.

8.3.3.5 Ground collectors

The installation of ground collectors shall take structural and environmental factors into account.

The depth and layout of ground collectors should be specified to avoid freezing of adjacent ground. Where open loop systems are proposed, consultation with the appropriate environment agency should be made and may require one or more of the following:

- a licence to investigate groundwater
- an abstraction licence
- a discharge consent.

Excavations for the installation of ground collectors should not adversely affect aquifers, foundations, drainage, water supply pipes and other services. Design should take account of local planning authority guidance, including excavations that are close to trees and hedgerows.

Ground collectors should be protected and tested prior to backfilling.

8.3.3.6 Building integration

Also see: Chapter 8.6

Heat pump system installation shall be securely fixed and not adversely affect the weather resistance of the building.

Foundations and anchor points for stand-alone heat pump technologies should be designed by an engineer in accordance with Technical Requirement R5 to withstand the structural forces acting upon them.

The structure to which the heat pump technology is attached should be assessed according to its ability to accept the loadings and prevent detrimental effects arising from movement or vibration.

The design of the structure should take account of:

- the self-weight of the heat pump components
- imposed loads
- wind loads
- dynamic loading (where relevant).

Notching, drilling or chasing of structural components to accommodate service pipes or cables should either comply with Part 8.7.1 or be designed by an engineer in accordance with Technical Requirement R5.

Fixings, supports, bracketry and mounting frames should:

- accommodate all static and dynamic loads in accordance with the manufacturer's recommendations
- have adequate protection against corrosion (grade 316 stainless steel is recommended for coastal locations)
- be compatible or isolated where two metals are to be joined to prevent bimetallic corrosion.

Aluminium and aluminium alloys should not come into contact with cementitious material.

All interfaces between the heat pump and the building should ensure adequate weather resistance, sealed to limit air leakage and prevent moisture from reaching the interior or any part of the structure that could be adversely affected by its presence. The envelope should be weatherproofed using appropriate flashings and fixings. Weatherproofing details that rely solely on sealant are not acceptable.

8.3.3.7 Fixing

Heat pump systems shall be securely fixed using durable materials.

Fixings should comply with the types listed in Table 14.

Table 14: Materials suitable for fixings

Fixing material	Guidance
Phosphor bronze	NA
Silicon bronze	NA
Stainless steel	BS EN ISO 3506
Mild steel	Coatings to BS EN ISO 2081, BS EN ISO 2082, BS EN 1461, or other appropriate treatment in accordance with BS EN ISO 12944 or BS EN ISO 14713
Aluminum alloy	BS EN 573 and BS EN 755
Stainless steel	BS EN 10088
Mild steel	BS EN 10346
Other materials	Assessed in accordance with Technical Requirement R3

Materials that comply with recognised standards, which provide equal or better performance to those above, are also acceptable. The type, size, number, position and fitting tolerance of fixings should be in accordance with the manufacturer's recommendations.

Issues that should be taken into account include:

- the provision of suitable locking nuts and washers
- the isolation of aluminium from cementitious material.
- the isolation of dissimilar metals

8.3.3.8 Access

Also see: Chapter 8

Appropriate arrangements shall be provided for the purposes of cleaning, inspection, maintenance, and repair or replacement of heat pump systems.

Safe access should be provided to the heat pump systems, including switchgear and controls. This is to enable the cleaning, inspection, maintenance, and repair of systems. Access should be provided in accordance with the manufacturer's recommendations.

8.3.3.9 Electrical installation requirements

Also see: Chapter: 8.1.6

The electrical installation shall be in accordance with relevant regulations.

Electrical installations should comply with BS 7671 'Requirements for Electrical Installations'.

The electrical installation should be capable of being isolated from all other electrical sources when required, for maintenance or testing.

The inclusion of any lightning protection must be installed as directed by the equipment manufacturer. Also see 8.1.6.15.

8.3.3.10 Handling and storage

Materials, products, and systems shall be handled, stored and protected in a satisfactory manner to prevent damage, distortion, weathering and degradation.

Heat pump systems should be:

- transported, lifted, handled and stored in accordance with the manufacturer's recommendations
- delivered in sequence to avoid storage
- protected to avoid the risk of damage.

8.3.3.11 Sequence of work

Heat pump systems shall be installed in accordance with a suitable schedule.

To ensure performance, heat pump systems and ancillary components should be installed in a logical and timely sequence in accordance with the manufacturer's recommendations.

Figure reference table

Figure reference table 8.3.3

Fig No	Title/Description	Clause	Page
Figure 1	Heat pump schematic	8.3.3	9
Figure 2	Air source heat pump	8.3.3	9
Figure 3	Ground source heat pump	8.3.3	9
Figure 4	Alternative heat sources (boreholes and slinkys)	8.3.3	9



Chapter

8.3.4



Biomass

Systems which burn wood pellets or chips for space and/or water heating.

8.3.4.1	Compliance	17
8.3.4.2	Clean air act	18
8.3.4.3	Fuel storage	18

For figure reference tables, please go to the end of each chapter.



Figure 1: Biomass schematic

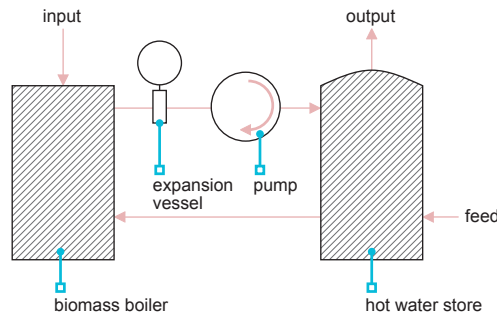

8.3.4.1 Compliance

Also see: Chapter 2.1

Biomass systems shall comply with the Technical Requirements. Issues to be taken into account include:

- 1) relevant standards
- 2) product certification
- 3) operative competency.

8.3.4.1.1 Relevant standards

Biomass systems should comply with relevant standards including where applicable:

BS EN 303-5	'Heating boilers for solid fuels, hand and automatically fired, nominal heat output of up to 300kW. Terminology, requirements, testing and marking'
BS EN 12809	Residential independent boilers fired by solid fuel
BS EN 13240	Room heaters fired by solid fuel, requirements, and test methods
BS EN 14785	'Residential space heating appliances fired by wood pellets
BS EN 14961-2	Condensing heating boilers installed and operated according to the product instructions up to nominal input 45kW
MCS 008	Product certification scheme requirements Biomass
MGD 006	Percussive events guidance
MIS 3004	Requirements for MCS contractors undertaking the supply, design, installation commissioning and handover of solid biofuel heating systems
MCS CC001	Biomass compliance certificate

8.3.4.1.2 Product certification

Biomass technologies should have current certification confirming satisfactory assessment by an appropriate independent authority acceptable to NHBC.

Systems, products and installations that are assessed through the Microgeneration Certification Scheme (MCS) will generally be acceptable to NHBC. Certification and test documentation should be made available to NHBC upon request.

Other certification bodies or test documentation may be acceptable where they are considered by NHBC to be a suitable alternative.

8.3.4.1.3 Operative competency

Biomass systems should be installed by operatives:

- competent and familiar with the system being installed, and
- certified to a standard acceptable to NHBC.
- MCS certified or

Where installers are not MCS accredited they should still hold the relevant qualifications:

- HETAS qualified
- electrically qualified.

8.3.4.2 Clean air act

Biomass boilers installed in smoke controlled areas shall comply with relevant legislation.

Biomass boilers to be installed within a smoke controlled area should comply with the Clean Air Act 1993 or Clean Air (Northern Ireland) Order 1981. Installations also need to consider any local air quality management plans that are in effect and comply with the requirements.

8.3.4.3 Fuel storage

Also see: The HVCA Guide to Good Practice Installation of Biofuel Heating (TR/38)

Fuel storage for biomass boilers shall be suitable for the installation.

Fuel stores should have appropriate access for delivery:

- fire detection and extinguishing equipment where elevated dust levels are expected
- fire resistance and separation to prevent fire and gases entering other parts of the building.
- volume to take account of peak load and period of demand

Figure reference table

Figure reference table 8.3.4			
Fig No	Title/Description	Clause	Page
Figure 1	Biomass schematic	8.3.4	17



Chapter

8.4



Ventilation

This chapter provides guidance for ventilation equipment including low or zero carbon sources (LZC), other (LZC) systems that follow the general principles of this chapter may also be acceptable, subject to specific agreement with NHBC.

This chapter contains the following sections:

- 8.4.1 Mechanical Ventilation and Heat Recovery system (MVHR)
- 8.4.2 Mechanical Extract Ventilation system (MEV)

For figure reference tables, please go to the end of each chapter.



Mechanical ventilation and heat recovery (MVHR)

MVHR (Mechanical Ventilation with Heat Recovery) systems provides fresh filtered air into a building whilst retaining most of the energy that has already been used in heating the air within the building see figure 1 & 2.

8.4.1.1	Compliance	01
8.4.1.2	Provision of information	02
8.4.1.3	System design	02
8.4.1.4	Acoustics	04
8.4.1.5	Building integration	04
8.4.1.6	Ductwork	05
8.4.1.7	Fixing and jointing of ductwork	05
8.4.1.8	Access and operation	06
8.4.1.9	Electrical installation requirements	06
8.4.1.10	Handling and storage	06
8.4.1.11	Commissioning and balancing	07
8.4.1.12	Sequence of work	07

For figure reference tables, please go to the end of each chapter.



Figure 1: MVHR schematic

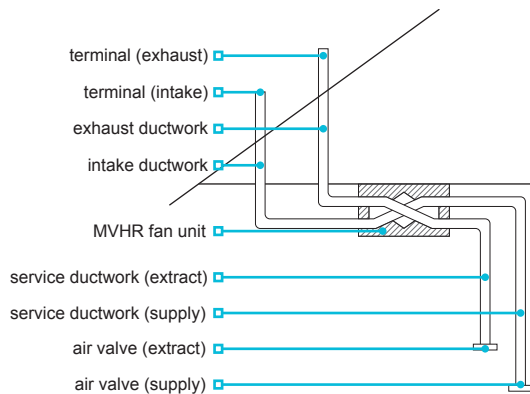
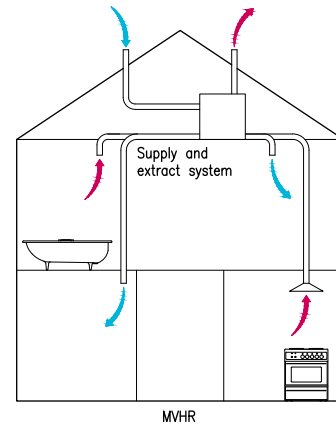

Figure 2: MVHR schematic layout



Definitions for MVHR

Air valve (extract and supply)	Wall or ceiling mounted fittings used to balance the flow rate of air between rooms; may be referred to as grilles or diffusers
Exhaust ductwork	Carries air from the fan unit and exhausts it to the external atmosphere
Intake ductwork	Carries air from the external atmosphere to the MVHR fan unit
MVHR fan unit	Unit that contains the fan(s), heat exchanger and filter(s)
Service ductwork extract and supply	Carries air between the air valves and the MVHR fan unit
Terminal fittings	Located on the outside of the building to finish the intake and exhaust ductwork

8.4.1.1 Compliance

Also see: Chapter 2.1

MVHR systems shall comply with the Technical Requirements. Issues to be taken into account include:

- 1) relevant standards
- 2) product certification
- 3) operative competency.

8.4.1.1.1 Relevant standards

Relevant standards include:

BS 476	'Fire tests on building materials and structures'
BS EN 1365-2	'Fire resistance tests for loadbearing elements. Floors and roofs'
BS EN 1366-3	'Fire resistance tests for service installations. Penetration seals'
BS EN 848-1, 2 & 5	Fans for general purposes, testing, noise and electrical safety
BS EN ISO 12001	Noise emitted by machinery and equipment
Approved Document F England	Ventilation
Technical handbook Scotland	Section 3 Ventilation
Technical Booklet NI	Part K Ventilation

8.4.1.1.2 Product certification

MVHR appliances should hold a current assessment by an appropriate independent technical approval's authority accepted by NHBC confirming compliance with UK CA, UK NI or CE marking:

- declaration of conformity detailing the standards the product complies with
- documents to be available on request.

8.4.1.1.3 Operative competency

MVHR systems should be installed by competent operatives:

- competent and familiar with the system being installed, installers who have been trained in accordance with the BPEC installers scheme would generally be acceptable to NHBC
- certified to a standard acceptable to NHBC.

8.4.1.2 Provision of information

Designs and specifications shall be produced in a clearly understandable format, include all relevant information and be distributed to the appropriate personnel.

Provision of information is important as it allows for energy efficient use of the building and common methods adopted to prevent overheating.

Clear and fully detailed drawings should be available on site to enable work to be carried out in accordance with the design. Designs should be issued to site supervisors, relevant specialist subcontractors and suppliers, and where used include the following information:

- fixing schedule
- a full set of current drawings
- indication of which manufacturer and/or installer is responsible for each system and interface
- commissioning schedule
- manufacturers' specifications
- interface details
- on-site testing requirements
- type and spacing of clips and fixings
- type and location of ancillary components, including those used for fire safety and acoustic purposes
- commissioning certificates
- location of all ductwork runs, the fan unit and controls
- type, size and position of ducts and terminals
- direction of fall for 'horizontal' ductwork
- designed airflow-balancing figures for the system
- thermal modelling.

8.4.1.3 System Design

MVHR systems shall be in accordance with relevant Building Regulations and designed to minimise disturbance caused by noise. Issues to be taken into account include:

- 1) location
- 2) system
- 3) compatibility
- 4) performance
- 5) air valve and terminals
- 6) control of condensation
- 7) protection from the cold.

8.4.1.3.1 Location

MVHR systems should be correctly located, including ancillary components, and should be located and identified in accordance with the manufacturer's recommendations.

8.4.1.3.2 System

MVHR systems should be in accordance with relevant Building Regulations and installed to ensure that effective ventilation is provided without affecting health or creating unnecessary noise.

8.4.1.3.3 Compatibility

The MVHR system should be designed as a complete package, taking into account the performance of all components and materials, to ensure compatibility and the performance requirements of the system.

Particular consideration should be given where components from different manufacturers are specified on the same system.

8.4.1.3.4 Performance

The MVHR system should be designed to provide satisfactory performance and be installed according to the design and manufacturer's recommendations. Variations from the design should maintain the satisfactory performance of the system and be approved by the designer.

Issues that should be taken into account include:

- ventilation rates as set out in appropriate Building Regulations and standards
- fan capacity, accounting for airflow resistance of the system
- ensuring the even distribution of airflow, taking into account regulations and standards airflow resistance, including from bends and fittings.

Airflow resistance should be calculated using figures for air valves and terminals determined in accordance with BS EN 13141-2 and data supplied by the duct manufacturer. Ductwork should be as direct as possible to reduce the number of bends.

Allowance should be made for air transfer within the home. Where gaps between the underside of internal doors and the floor finish are used for air transfer, the guidance in Chapter 9.1 'A consistent approach to finishes' should be considered.

8.4.1.3.5 Air valves and terminals

Air valves should be selected according to location and function, ensuring appropriate specification for:

- wall or ceiling location
- supply or extract function
- the velocity of the system.

To create cross-ventilation within a room and to ensure satisfactory operation, air valves on low velocity systems should be:

- positioned on the opposite side of the room from internal door openings
- a minimum of 200mm from walls, where located on a ceiling
- a maximum of 400mm from the ceiling, located on a wall
- a minimum of 600mm (on plan) from hobs in kitchens
- positioned to account for the likely location of tall furniture and to avoid draughts over beds and seating areas
- lockable, where adjustable.

To prevent cross-contamination, intake terminals should generally be separated from exhaust terminals and other potential sources of pollution by a minimum of 1m measured on plan. Increased separation distances may be required between the intake and any:

- soil and vent pipe terminal
- boiler flue outlet
- biomass or solid fuel chimney terminal.

Terminals should prevent the entry of birds and animals.

8.4.1.3.6 Control of condensation

Ductwork should be insulated to prevent condensation formation where:

- it passes through spaces outside the insulated parts of the home, such as a roof void
- carrying cold air through spaces that are within the insulated parts of the home.

This can be achieved by using suitable pre-insulated ductwork, or a proprietary insulation system with a thermal resistance equivalent to a minimum of 25mm of insulating material, with a thermal conductivity of 0.04W/Mk.

Ductwork insulation, including that used for proprietary duct insulation systems and pre-insulated ducts should be:

- inert, durable, and suitable for use with the ductwork system
- continuous and vapour resistant
- not adversely affected by moisture vapour
- installed in a neat and workmanlike manner to ensure that there are no gaps
- installed in accordance with the manufacturer's recommendations.

Where a vapour control layer is incorporated, the joints should be sealed using appropriate tapes or sealants as recommended by the manufacturer.

Table 1: Ductwork insulation

Type of duct	Ductwork continuously insulated	
	Ductwork located inside the insulated part of the home	Ductwork located outside the insulated part of the home
Intake	Yes	Yes
Exhaust	Yes	Yes
Service (supply and extract)	No	Yes ⁽¹⁾

Notes

¹ Additional insulation should be provided to protect the system from the cold.

Any condensate that forms within the fan unit or ductwork should be able to drain to a suitable outfall. Fan units should be located to enable connection of the condensate drain to the soil and waste system via a dry trap.

8.4.1.3.7 Protection from the cold

MVHR systems should be protected from the effects of cold. Issues to be taken into account include:

- performance in relation to indoor air quality
- the manufacturer’s recommendations where any parts are located outside the insulated part of the home
- insulation of ductwork and other system components.

Figure 3: Protection from the cold

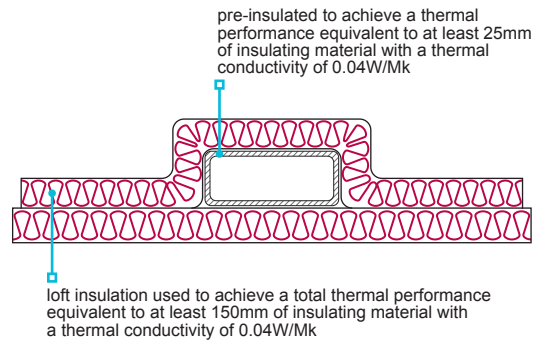

To prevent damage to the components and ensure satisfactory operation, MVHR systems should be fitted with automatic frost protection.

Horizontal sections of service ductwork, outside the insulated parts of the home, should be insulated to achieve a thermal resistance equivalent to at least 150mm of insulating material with a thermal conductivity of 0.04W/Mk. This may be achieved by installing the ductwork between the layers of horizontal insulation. See figure 3.

Condensate drains located outside the insulated part of the home should be insulated to prevent freezing.

8.4.1.4 Acoustics

MVHR systems shall be designed to minimise disturbance caused by noise.

MVHR fan units should be sized to run at their optimum speed and to provide suitable performance whilst taking the resulting noise and vibration into account. Specifying MVHR fan units that can provide the required airflow rates when running at less than full speed can reduce unnecessary noise.

Ductwork should be sized to allow air to pass freely without causing excessive noise disturbance. To reduce noise transfer along ductwork, a short length of flexible duct can be installed adjacent to air valves and fan units. Other issues to be taken into account include:

- noise between habitable rooms
- external noise
- location of the MVHR fan unit
- the type of mountings used to secure the MVHR fan unit.

8.4.1.5 Building integration

Also see: Chapter 7.1, 7.2 and 8.6

MVHR systems shall be securely fixed and not adversely affect the weather resistance of the building.

Issues to be taken into account include:

- 1) weather tightness
- 2) fixing of fan units
- 3) fire-stopping.

8.4.1.5.1 Weather tightness

Proprietary roof terminals should be used to ensure the weathertightness of the roof covering.

8.4.1.5.2 Fixing of fan units

MVHR fan units should only be fixed to parts of the building capable of taking the load. Where MVHR fan units are supported by framed structures, additional components such as noggins may be required to provide a secure fixing point.

Fan units should be located, orientated, and fixed in accordance with the design, using the clips, brackets and fixings recommended by the manufacturer.

8.4.1.5.3 Fire-stopping

The MVHR system should not adversely affect the fire performance of the building. Issues to be taken into account include:

- ensuring that the fire requirements of the building are in accordance with relevant Building Regulations
- suitable detailing of components passing through other elements of the building
- location and type of firestops to be used
- integrity of protected stairs and halls
- integrity of walls and floors.

Proprietary passive fire protection components should be suitably tested and specified to take account of the test conditions.

8.4.1.6 Ductwork

Also see: Chapter 8.4.2.7

Ductwork design and the materials used should be suitable for the intended purpose and not adversely affect the performance of the building. MVHR ductwork and insulation should be installed to a satisfactory standard.

Where ductwork routes require alterations to structural elements, these should be in accordance with the manufacturer's recommendations or in accordance with Technical Requirement R5.

Ductwork should:

- provide satisfactory performance for the life of the system
- be routed as directly as practicable
- be of a rigid or semi-rigid material suitable for use in MVHR systems see figure 4
- be fixed in accordance with the manufacturer's recommendations.

Bends, connections and junctions should be formed using proprietary components that are part of the ductwork system.

Flexible ducting should:

- only be located adjacent to fan units or air valves
- not be more than 300mm in length
- not be used to form bends.

Figure 4: Air valve and ductwork

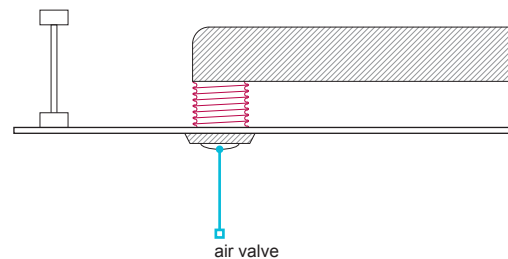

8.4.1.7 Fixing and jointing of ductwork

MVHR ductwork and insulation shall be installed to a satisfactory standard. Issues to be taken into account include:

- 1) fixing
- 2) jointing.

Ductwork should be installed in a neat and workmanlike manner.

8.4.1.7.1 Fixing

To prevent condensate collecting, horizontal ductwork should be to a suitable outfall in accordance with the design and installed to a true line to avoid localised dips. Where parallel ductwork is run it should be positioned to maintain an even gap.

Where ductwork passes through an external wall, it should be positioned to slope slightly downwards to prevent water entering the building.

Ductwork should be securely held in position by evenly spaced clips no more than 750mm apart, or in accordance with the ductwork manufacturer's recommendations.

Ductwork should not be in direct contact with other surfaces, such as plasterboard ceilings, that may transfer noise to the home.

8.4.1.7.2 Jointing of ductwork

The method and materials used for jointing ductwork should be specified by the duct manufacturer, and be:

- durable and airtight
- securely fixed
- sealed with purpose-designed connections in accordance with the manufacturer's recommendations.

Where tapes and sealants are used, they should be suitable for the intended purpose and be recommended by the ductwork manufacturer. Issues to be taken into account in relation to the durability of the joining method include:

- thermal movement
- moisture
- temperature
- compatibility with the duct material.

Tape should be installed in a neat and workmanlike manner, and surfaces should be dry and free from grease and dust before applying. Excess sealant should not extrude to the inside of the duct.

8.4.1.8 Access and operation

MVHR systems shall be designed and installed to ensure that the fan unit and associated controls are easily accessible for the purposes of cleaning, inspection, maintenance, and repair or replacement.

Safe access should be provided to MVHR systems, including switchgear, and controls. This is to enable the cleaning, inspection, maintenance and repair of systems. Access should be provided in accordance with the manufacturer’s recommendations.

Where plant is to be installed in a loft or roof void additional guidance is provided in chapter 7.2.12.

Table 2: Guidance for the suitable functioning of, and access to, the MVHR system

	Fan unit located inside the insulated part of the home	Fan unit located outside the insulated part of the home
Access	Access should not be obstructed and panels should be located and sized to enable routine servicing to be carried out	A safe means of access, including a suitable walkway and a working platform 1m ² immediately adjacent to the MVHR fan unit, should be provided. The walkway and platform should be designed to ensure the continuity of any insulation, and the supporting structure should be designed to take account of the additional load
Control and functionality	Where a ‘boost’ function is provided, it should switch off automatically and be located in, or adjacent to, the room it serves. Where a ‘summer bypass’ function is provided, it should operate automatically and divert the airflow around the heat exchanger. The MVHR system should be capable of being isolated by a switched fused spur	
Indication and controls	MVHR systems should include visual indicators showing maintenance and servicing requirements, and mode of operation. These should be visible from within the insulated envelope, not obscured from view, and be simple to use	
Cleaning	To maintain operating performance, extract service ductwork and air valves should either be fitted with filters, or ductwork should be accessible for cleaning	

8.4.1.9 Electrical installation requirements

Also see: Chapter: 8.1.6

The electrical installation shall be in accordance with relevant regulations.

Electrical installations should comply with BS 7671 ‘Requirements for Electrical Installations’.

The electrical installation should be capable of being isolated from all other electrical sources when required, for maintenance or testing.

The inclusion of any lightning protection must be installed as directed by the equipment manufacturer. Also see 8.1.6.15.

8.4.1.10 Handling and storage

Materials, products, and systems shall be handled, stored and protected in a satisfactory manner to prevent damage, distortion, weathering and degradation.

MVHR systems should be:

- transported, lifted, handled and stored in accordance with the manufacturer’s recommendations
- delivered in sequence to avoid storage
- protected to avoid the risk of damage.

To ensure performance, MVHR systems and ancillary components should be installed in a logical and timely sequence in accordance with the manufacturer’s recommendations.

8.4.1.11 Commissioning and balancing

MVHR design, materials and sitework shall be tested and commissioned in accordance with the commissioning schedule.

Upon completion of the installation MVHR systems should be protected from dust during the construction of the home. Where possible the system should be switched off and dust covers applied to air valves.

Prior to completion of the home, the system:

- including ductwork and filters, should be checked to ensure it is clear from dirt and dust that may have accumulated during construction
- should be commissioned to confirm performance
- should be adjusted by using the air valves and controls to achieve the correct balancing and airflow rates
- should have air valves locked in position after correct commissioning and balancing.

Where the system cannot be balanced using the air valves and system controls, the complete system should be checked to ensure that it complies with the design.

Any changes from the design should be referred to the designer. Adjusting the fan speed above the designed output may result in noise disturbance and should be avoided.

A copy of the commissioning certificate should be made available to NHBC upon request.

8.4.1.12 Sequence of work

MVHR systems shall be installed in accordance with a suitable schedule.

To ensure performance, MVHR systems and ancillary components should be installed in a logical and timely sequence in accordance with the manufacturer's recommendations.

Figure reference table

Figure reference table 8.4.1			
Fig No	Title/Description	Clause	Page
Figure 1	MVHR schematic	8.4.1	1
Figure 2	MVHR schematic layout	8.4.1	1
Figure 3	Protection from the cold	8.4.1.3.7	4
Figure 4	Air valve and ductwork	8.4.1.6	5

Mechanical extract ventilation systems (MEV)

Bathroom and kitchen extract fans providing decentralised extract ventilation (dMEV) or central mechanical extract ventilation (cMEV) and may be continuous or intermittent depending on design and location.

8.4.2.1	Compliance	09
8.4.2.2	Provision of information	10
8.4.2.3	System design	10
8.4.2.4	Acoustics	12
8.4.2.5	Building integration	12
8.4.2.6	Ductwork	13
8.4.2.7	Fixing and jointing of ductwork	13
8.4.2.8	Access and operation	14
8.4.2.9	Electrical installation requirements	14
8.4.2.10	Handling and storage	14
8.4.2.11	Commissioning and balancing	14
8.4.2.12	Sequence of work	14

For figure reference tables, please go to the end of each chapter.



Figure 1: dMEV layout

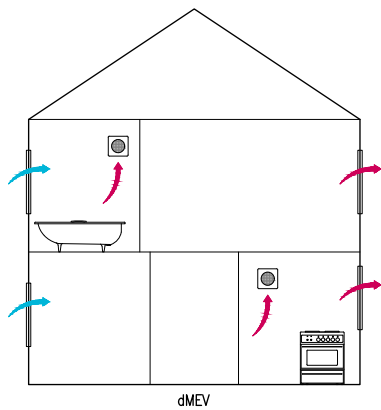
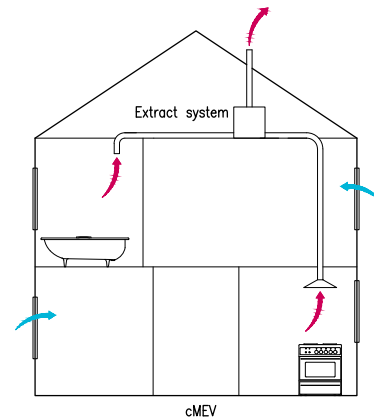

Figure 2: cMEV layout



Definitions for MEV

Air valve (extract)	Wall or ceiling mounted fittings used to balance the flow rate of air between rooms; may be referred to as grilles
cMEV	Continuous mechanical extract ventilation system providing simultaneous ventilation to reduce excess moisture using multipoint extraction points
dMEV	Mechanical extract ventilation system providing ventilation to reduce excess moisture using single extraction point
Exhaust ductwork	Carries air from the fan unit and exhausts it to the external atmosphere
MEV	Relates to a generic term relating to both cMEV and dMEV
Service ductwork extract	Carries air between the air valves and the MVHR fan unit
Terminal fittings	Located on the outside of the building to finish the intake and exhaust ductwork

8.4.2.1 Compliance

Also see: Chapter 2.1

MEV design, materials and sitework shall comply with the Technical Requirements, issues to be taken into account include:

- 1) relevant standards
- 2) product certification
- 3) operative competency.

8.4.2.1.1 Relevant standards

Relevant standards include:

BS 476	'Fire tests on building materials and structures'
BS EN 1365-2	'Fire resistance tests for loadbearing elements. Floors and roofs'
BS EN 1366-3	'Fire resistance tests for service installations. Penetration seals'
BS EN 848-1, 2 & 5	Fans for general purposes, testing, noise and electrical safety
BS EN ISO 12001	Noise emitted by machinery and equipment
Approved Document F England	Ventilation
Technical handbook Scotland	Section 3 Ventilation
Technical Booklet NI	Part K Ventillation

8.4.2.1.2 Product certification

MEV appliances should hold a current assessment by an appropriate independent technical approvals authority accepted by NHBC confirming compliance with UK CA, UK NI or CE marking:

- declaration of conformity detailing the standards the product complies with
- documents to be available on request.

8.4.2.1.3 Operative competency

MEV systems should be installed by competent operatives:

- competent and familiar with the system being installed, and or
- certified to a standard acceptable to NHBC.

8.4.2.2 Provision of information

Designs and specifications shall be produced in a clearly understandable format, include all relevant information and be distributed to the appropriate personnel.

Provision of information is important as it allows for energy efficient use of the building and common methods adopted to prevent overheating.

Clear and fully detailed drawings should be available on site to enable work to be carried out in accordance with the design. Designs should be issued to site supervisors, relevant specialist subcontractors and suppliers, and where used include the following information:

- fixing schedule
- a full set of current drawings
- indication of which manufacturer and/or installer is responsible for each system and interface
- commissioning schedule
- manufacturers' specifications
- interface details
- on-site testing requirements
- type and spacing of clips and fixings
- type and location of ancillary components, including those used for fire safety and acoustic purposes
- commissioning certificates
- location of all ductwork runs, the fan unit and controls
- type, size and position of ducts and terminals
- direction of fall for 'horizontal' ductwork
- designed airflow-balancing figures for the system
- thermal modelling.

8.4.2.3 System Design

MEV systems shall be designed to minimise disturbance caused by noise. Issues to be taken into account include:

- | | |
|------------------|----------------------------|
| 1) location | 4) performance |
| 2) system | 5) control of condensation |
| 3) compatibility | 6) terminals. |

8.4.2.3.1 Location

MEV systems should be correctly located, including ancillary components, in accordance with the manufacturer's recommendations.

The route of ductwork should take account of other building elements. Ductwork passing through structural elements should not adversely affect the structural or fire performance of the building. Where alterations to structural elements, such as I-joists, are required, this should only be carried out in accordance with the manufacturer's recommendations or be designed by an engineer in accordance with Technical Requirement R5.

The fire requirements of the building should be in accordance with relevant Building Regulations and standards. Issues that should be taken into account include:

- suitable detailing of components passing through other elements of the building
- the location and type of dampers and firestops to be used
- the integrity of protected stairs and halls
- the integrity of walls and floors.

8.4.2.3.2 System

MEV systems should be in accordance with relevant Building Regulations and installed to ensure that effective ventilation is provided without affecting health or creating unnecessary noise.

8.4.2.3.3 Compatibility

MEV systems should ensure compatibility with other building elements and not adversely affect the performance of the building.

The MEV system should be designed as a complete package, taking into account the performance of all components and materials, to ensure compatibility and the performance requirements of the system.

Particular consideration should be given where components from different manufacturers are specified on the same system.

8.4.2.3.4 Performance

The MEV system should be designed to provide satisfactory performance and be installed according to the design and manufacturer's recommendations. Variations from the design should maintain the satisfactory performance of the system and be approved by the designer.

Issues that should be taken into account include:

- ventilation rates as set out in appropriate Building Regulations and standards
- fan capacity, accounting for airflow resistance of the system
- ensuring the even distribution of airflow, taking into account regulations and standards airflow resistance, including from bends and fittings
- airflow resistance should be calculated using figures for air valves and terminals determined in accordance with BS EN 13141-2 and data supplied by the duct manufacturer. Ductwork should be as direct as possible to reduce the number of bends.

Allowance should be made for air transfer within the home. Where gaps between the underside of internal doors and the floor finish are used for air transfer, the guidance in Chapter 9.1 'A consistent approach to finishes' should be considered.

8.4.2.3.5 Control of condensation

Where extract ductwork passes through unheated spaces, it should be continuously insulated to achieve a thermal resistance equivalent to a minimum of 25mm of insulating material with a thermal conductivity of 0.04W/(mK). This can be achieved by using:

- suitable pre-insulated ductwork, or
- a proprietary insulation system. See figure 3.

Alternatively, the ductwork can be fitted with a condensate trap that discharges to the outside or installing the duct to slope to the outside. See figure 4.

Figure 3: Ventilation control condensation - insulation

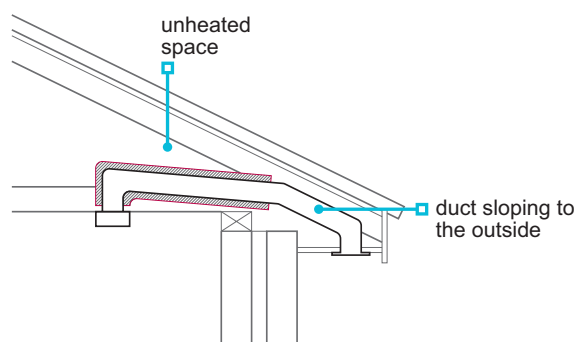
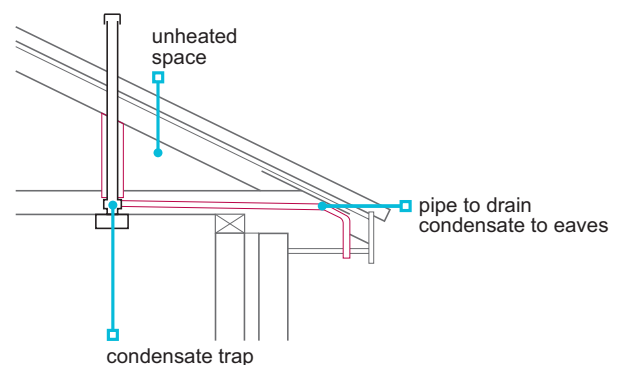

Figure 4: Ventilation control condensation - condense trap



8.4.2.3.6 Terminals

Ventilation systems should terminate freely to open air.

The air flow resistance of terminals should not adversely affect the performance of the ventilation system. Airflow resistance of terminals can be obtained through testing in accordance with BS EN 13141-2. See figure 5.

Figure 5: Termination to ventilation systems

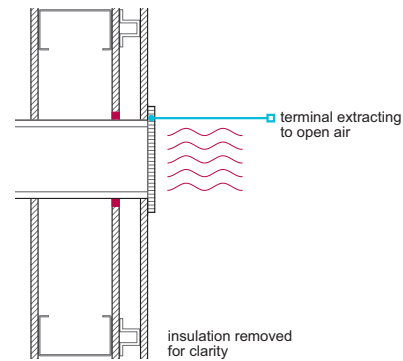

8.4.2.4 Acoustics

MEV systems shall be designed to minimise disturbance caused by noise.

MEV fan units should be sized to run at their optimum speed and to provide suitable performance whilst taking the resulting noise and vibration into account. Specifying MEV fan units that can provide the required airflow rates when running at less than full speed can reduce unnecessary noise.

Ductwork should be sized to allow air to pass freely without causing excessive noise disturbance. To reduce noise transfer along ductwork, a short length of flexible duct can be installed adjacent to air valves and fan units. Other issues to be taken into account include:

- noise between habitable rooms
- external noise
- location of the MEV fan unit
- the type of mountings used to secure the MEV fan unit.

8.4.2.5 Building integration

Chapter 7.1, 7.2 and 8.6

MEV design, materials and sitework shall comply with the Technical Requirements, Issues to be taken into account include:

- 1) weathertightness
- 2) fixing of fan units
- 3) fire-stopping.

8.4.2.5.1 Weathertightness

Proprietary roof terminals should be used to ensure the weathertightness of the roof covering.

8.4.2.5.2 Fixing of fan units

MEV fan units should only be fixed to parts of the building capable of taking the load. Where MEV fan units are supported by framed structures, additional components such as noggings may be required to provide a secure fixing point.

Fan units should be located, orientated, and fixed in accordance with the design, using the clips, brackets and fixings recommended by the manufacturer.

The type, size, number, position and fitting tolerance of fixings should be in accordance with the manufacturer's recommendations.

8.4.2.5.3 Fire-stopping

The MEV system should not adversely affect the fire performance of the building. Issues to be taken into account include:

- ensuring that the fire requirements of the building are in accordance with relevant Building Regulations
- suitable detailing of components passing through other elements of the building
- location and type of firestops to be used
- integrity of protected stairs and halls
- integrity of walls and floors.

Proprietary fire components should be suitably tested, and specified to take account of the test conditions.

8.4.2.6 Ductwork

Also see: Chapter 8.4.1.6

Ductwork to intermittent and continuously running mechanical extract ventilation systems shall ensure satisfactory performance and durability. Issues to be taken into account include:

- 1) resistance to airflow
- 2) installation of ductwork.

8.4.2.6.1 Resistance to airflow

Ductwork systems should be designed to minimise the resistance to airflow and be formed from compatible components.

Rigid duct is preferable to flexible, but where flexible duct is used, it should be restricted in length to ensure that the airflow resistance does not prevent the designed ventilation rate from being achieved. Flexible duct should be installed:

- straight
- in accordance with the manufacturer's recommendations.

Bends should generally be formed with proprietary rigid components. Where flexible duct is used to form bends on an intermittent extract system, they should be restricted to a maximum of:

- two for systems up to 30 L/s
- one for extract rates higher than 30 L/s.

8.4.2.6.2 Installation of ductwork

Ductwork should be installed in a neat and workmanlike manner, be securely fixed, and have:

- adequate support throughout its length
- sealed mechanically fixed joints and connections.

Where ductwork passes through an external wall, it should be positioned to slope slightly outwards to prevent water entering the building. Clips and supports for ductwork should be spaced at equal distances and in accordance with the ductwork manufacturer's recommendations. For rigid ductwork, they should not generally be more than 750mm apart.

Ductwork should not be in direct contact with other surfaces, such as plasterboard ceilings, that may transfer noise to the home.

It is not necessary to provide non-return shutters on extract fans or cooker hoods or their ducting unless specifically required by the manufacturer's installation instructions.

8.4.2.7 Fixing and jointing of ductwork

MEV ductwork and insulation shall be installed to a satisfactory standard. Issues to be taken into account include:

- 1) fixing
- 2) jointing.

Ductwork should be installed in a neat and workmanlike manner.

8.4.2.7.1 Fixing

To prevent condensate collecting, horizontal ductwork should be to a suitable outfall in accordance with the design and installed to a true line to avoid localised dips. Where parallel ductwork is run it should be positioned to maintain an even gap.

Where ductwork passes through an external wall, it should be positioned to slope slightly downwards to prevent water entering the building.

Ductwork should be securely held in position by evenly spaced clips no more than 750mm apart, or in accordance with the ductwork manufacturer's recommendations.

Ductwork should not be in direct contact with other surfaces, such as plasterboard ceilings, that may transfer noise to the home.

8.4.2.7.2 Jointing of ductwork

The method and materials used for jointing ductwork should be specified by the duct manufacturer, and be:

- durable and airtight
- securely fixed
- sealed with purpose-designed connections in accordance with the manufacturer's recommendations.

Where tapes and sealants are used, they should be suitable for the intended purpose and be recommended by the ductwork manufacturer. Issues to be taken into account in relation to the durability of the jointing method include:

- thermal movement
- moisture
- temperature
- compatibility with the duct material.

Tape should be installed in a neat and workmanlike manner, and surfaces should be dry and free from grease and dust before applying. Excess sealant should not extrude to the inside of the duct.

8.4.2.8 Access and operation

MEV systems shall be designed and installed to ensure that the fan unit and associated controls are easily accessible for the purposes of cleaning, inspection, maintenance, and repair or replacement.

Safe access should be provided to MEV systems including switchgear and controls. This is to enable the cleaning, inspection, maintenance and repair of systems. Access should be provided in accordance with the manufacturer's recommendations.

Where plant is to be installed in a loft or roof void guidance is provided in chapter 7.2.12.

8.4.2.9 Electrical installation requirements

Also see: Chapter: 8.1.6

The electrical installation shall be in accordance with relevant regulations.

Electrical installations should comply with BS 7671 'Requirements for Electrical Installations'.

The electrical installation should be capable of being isolated from all other electrical sources when required, for maintenance or testing.

The inclusion of any lightning protection must be installed as directed by the equipment manufacturer. Also see 8.1.6.15.

8.4.2.10 Handling and storage

Materials, products, and systems shall be handled, stored and protected in a satisfactory manner to prevent damage, distortion, weathering and degradation.

MEV systems should be:

- transported, lifted, handled and stored in accordance with the manufacturer's recommendations
- delivered in sequence to avoid storage
- protected to avoid the risk of damage.

8.4.2.11 Commissioning and balancing

MEV design, materials and sitework shall be tested and commissioned in accordance with the commissioning schedule.

Upon completion of the installation MEV systems should be protected from dust during the construction of the home. Where possible the system should be switched off and dust covers applied to air valves.

8.4.2.12 Sequence of work

MEV systems shall be installed in accordance with a suitable schedule.

To ensure performance, MEV systems and ancillary components should be installed in a logical and timely sequence in accordance with the manufacturer's recommendations.

Figure reference table

Figure reference table 8.4.2			
Fig No	Title/Description	Clause	Page
Figure 1	dMEV layout	8.4.2	9
Figure 2	cMEV layout	8.4.2	9
Figure 3	Ventilation control condensation - insulation	8.4.2.3.5	12
Figure 4	Ventilation control condensation - condense trap	8.4.2.3.5	12
Figure 5	Termination to ventilation systems	8.4.2.3.6	12



Chapter 8.5



LZC Hot water systems

Chapter 8.5 provides guidance for equipment and installation of low or zero carbon sources (LZC), that provide hot water only. Other (LZC) systems that follow the general principles of this chapter may also be acceptable, subject to specific agreement with NHBC.

This chapter contains the following sections:

8.5.1 Solar thermal hot water system

For figure reference tables, please go to the end of each chapter.





Chapter

8.5.1



Solar thermal hot water systems

Systems which convert solar radiation energy to space and/or water heating.

8.5.1.1	Compliance	01
8.5.1.2	Provision of information	02
8.5.1.3	System design	02
8.5.1.4	Safe discharge	03
8.5.1.5	Building integration	03
8.5.1.6	Fixing	03
8.5.1.7	Access	04
8.5.1.8	Electrical installation requirements	04
8.5.1.9	Handling and storage	04
8.5.1.10	Handover requirements	04
8.5.1.11	Sequence of work	04

For figure reference tables, please go to the end of each chapter.



Figure 1: Solar thermal schematic

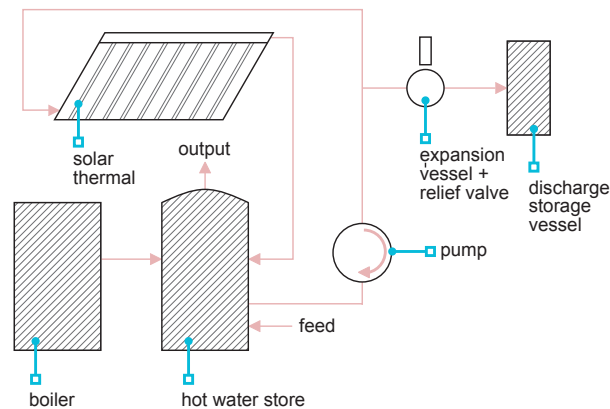

Definitions for solar thermal water heating

Coastal locations	A site within a distance of 500m from the general coastline of the United Kingdom
Low or zero carbon (LZC) technologies	A term applied to renewable sources of energy, and also to technologies which are significantly more efficient than traditional solutions, or which emit less carbon in providing heating, cooling or power
Performance	The manner or quality of functioning for a material, product or system
Renewable energy	Energy from naturally available sources that can be replenished, including energy from the sun, the wind and tides, and from replaceable matter such as wood or other plant material

8.5.1.1 Compliance

Also see: Chapter 2.1

Solar thermal systems shall comply with the Technical Requirements. Issues to be taken into account include:

- 1) relevant standards
- 2) product certification
- 3) operative competency.

LZC technologies that comply with the guidance in this chapter will generally be acceptable.

8.5.1.1.1 Relevant standards

Solar thermal hot water systems should comply with relevant standards including where applicable:

BS EN 12975-1	'Thermal solar systems and components. Solar collectors'
BS EN 12976-1	'Thermal solar systems and components. Factory made systems'
BS EN 9806	Methods for testing durability, reliability, safety and thermal performance of fluid heating solar collectors
BRE Digest DIG 489	Wind loads on roof mounted PV and solar thermal systems
MCS 004	Microgeneration Certification Scheme requirements for solar collectors
MCS 012	Product certification scheme requirements for solar mounting kits
MIS 3001	Microgeneration Installation Standard for solar thermal installation

8.5.1.1.2 Product certification

Solar thermal hot water technologies should have current certification confirming satisfactory assessment by an appropriate independent authority acceptable to NHBC.

Systems, products and installations that are assessed through the Microgeneration Certification Scheme (MCS) will generally be acceptable to NHBC. Certification and test documentation should be made available to NHBC upon request.

Other certification bodies or test documentation may be acceptable where they are considered by NHBC to be a suitable alternative.

8.5.1.1.3 Operative competency

Solar thermal hot water systems should be installed by operatives:

- competent and familiar with the system being installed, and
- certified to a standard acceptable to NHBC.
- MCS certified or

8.5.1.2 Provision of information

Designs and specifications shall be produced in a clearly understandable format, include all relevant information and be distributed to the appropriate personnel.

Provision of information is important as it allows for energy efficient use of the building and common methods adopted to prevent overheating.

Clear and fully detailed drawings should be available on site to enable work to be carried out in accordance with the design. Designs should be issued to site supervisors, relevant specialist subcontractors and suppliers, and where used include the following information:

- fixing schedule
- a full set of current drawings
- indication of which manufacturer and/or installer is responsible for each system and interface
- commissioning schedule
- manufacturers' specifications
- interface details
- on-site testing requirements
- type and spacing of clips and fixings
- type and location of ancillary components, including those used for fire safety and acoustic purposes
- commissioning certificates
- location and size of water storage cisterns and cylinders
- hot water pipe runs.

8.5.1.3 System Design

Solar thermal hot water systems shall be designed to ensure satisfactory performance. Issues to be taken into account include:

- | | |
|-------------|------------------|
| 1) location | 3) compatibility |
| 2) system | 4) performance. |

8.5.1.3.1 Location

Solar thermal hot water systems should be correctly located.

Solar thermal collectors, including ancillary components should be located and identified in accordance with the manufacturer's recommendations.

Solar thermal hot water when sited in coastal locations should be suitable for the environment. Manufacturers recommendations should be followed detailing requirements.

8.5.1.3.2 System

Solar thermal hot water systems should be designed in accordance with the manufacturer's recommendations, certification scheme requirements and appropriate standards.

Each system should generally be supplied from one manufacturer as a package and not as individual components or materials. However, where components from more than one manufacturer are used, they should be compatible to ensure satisfactory performance.

Solar thermal systems should be designed to prevent stagnation and damage to the collectors from oversizing.

8.5.1.3.3 Compatibility

Solar thermal hot water systems should be installed so as not to adversely affect the performance of the building to which they are fixed, and accordance with the manufacturer's recommendations.

Multiple systems should be compatible with each other.

8.5.1.3.4 Performance

If solar thermal systems are designed to contribute towards space and water heating should be designed in accordance with the performance requirements in Chapter 8.3 and 8.5.

8.5.1.4 Safe discharge

Discharge from solar thermal hot water systems shall terminate safely.

Solar thermal water heating systems should discharge into a storage vessel. The discharge pipework and vessel should be suitable to withstand high temperatures.

8.5.1.5 Building integration

Also see: Chapter 7.2.15, 7.2.17 and Chapter 8.6

Solar thermal hot water system installation shall be securely fixed and not adversely affect the weather resistance of the building.

Foundations and anchor points for stand-alone solar thermal technologies should be designed by an engineer in accordance with Technical Requirement R5 to withstand the structural forces acting upon them.

The structure to which the solar thermal technology is attached should be assessed according to its ability to accept the loadings and prevent detrimental effects arising from movement or vibration.

The design of the structure should take account of:

- the self-weight of the solar thermal components
- imposed loads
- wind loads
- dynamic loading (where relevant).

Notching, drilling or chasing of structural components to accommodate service pipes or cables should either comply with Chapter 8.7.1 or be designed by an engineer in accordance with Technical Requirement R5.

Fixings, supports, bracketry and mounting frames should:

- accommodate all static and dynamic loads in accordance with the manufacturer's recommendations
- have adequate protection against corrosion (grade 316 stainless steel is recommended for coastal locations)
- be compatible or isolated where two metals are to be joined to prevent bimetallic corrosion.

Aluminium and aluminium alloys should not come into contact with cementitious material.

All interfaces between the LZC technology and the building should ensure adequate weather resistance, sealed to limit air leakage and prevent moisture from reaching the interior or any part of the structure that could be adversely affected by its presence. The envelope should be weatherproofed using appropriate flashings and fixings. Weatherproofing details that rely solely on sealant are not acceptable.

8.5.1.6 Fixing

Solar thermal hot water systems shall be securely fixed using durable materials.

Fixings should comply with the types listed in Table 22.

Table 22: Materials suitable for fixings

Fixing material	Guidance
Phosphor bronze	NA
Silicon bronze	NA
Stainless steel	BS EN ISO 3506
Mild steel	Coatings to BS EN ISO 2081, BS EN ISO 2082, BS EN 1461, or other appropriate treatment in accordance with BS EN ISO 12944 or BS EN ISO 14713
Aluminum alloy	BS EN 573 and BS EN 755
Stainless steel	BS EN 10088
Mild steel	BS EN 10346
Other materials	Assessed in accordance with Technical Requirement R3

Materials that comply with recognised standards, which provide equal or better performance to those above, are also acceptable. The type, size, number, position and fitting tolerance of fixings should be in accordance with the manufacturer's recommendations. Issues that should be taken into account include:

- the provision of suitable locking nuts and washers
- the isolation of aluminium from cementitious material.
- the isolation of dissimilar metals

8.5.1.7 Access

Solar thermal systems shall be designed and installed to ensure the collectors and associated controls are easily accessible for the purposes of cleaning, inspection, maintenance, and repair or replacement.

Safe access should be provided to the solar thermal system, including switchgear and controls. This is to enable the cleaning, inspection, maintenance, and repair of systems. Access should be provided in accordance with the manufacturer's recommendations.

8.5.1.8 Electrical installation requirements

Also see: Chapter 8.1.6

The electrical installation shall be in accordance with relevant regulations.

Electrical installations should comply with BS 7671 'Requirements for Electrical Installations'.

The electrical installation should be capable of being isolated from all other electrical sources when required, for maintenance or testing.

The inclusion of any lightning protection must be installed as directed by the equipment manufacturer. Also see 8.1.6.15.

8.5.1.9 Handling and storage

Materials, products, and systems shall be handled, stored and protected in a satisfactory manner to prevent damage, distortion, weathering and degradation.

Solar thermal systems should be:

- transported, lifted, handled and stored in accordance with the manufacturer's recommendations
- delivered in sequence to avoid storage
- protected to avoid the risk of damage.

8.5.1.10 Handover requirements

Detailed information and instructions shall be provided to the homeowner.

The pack of information provided to the homeowner should include:

- user instructions for the systems installed
- contact details for the manufacturer and installer
- key components installed
- a completed manufacturer's certificate from an acceptable independent assessment organisation, MCS or suitable alternative
- maintenance and servicing requirements
- warranties and/or guarantees
- solar collectors should be protected from distortion if not filled with solar fluid in line with manufacturer's recommendations.

8.5.1.11 Sequence of work

Solar thermal hot water systems shall be installed in accordance with a suitable schedule.

To ensure performance, solar thermal hot water systems and ancillary components should be installed in a logical and timely sequence in accordance with the manufacturer's recommendations.

Figure reference table**Figure reference table 8.5.1**

Fig No	Title/Description	Clause	Page
Figure 1	Solar thermal schematic	8.5.1	1



Chapter 8.6



Installation and commissioning

This chapter provides guidance for installation, insulation to services, commissioning, and handover requirements for information to be provided to the homeowner. This chapter should be used as extended information for chapters 8.1 to 8.5

8.6.1	Compliance	01
8.6.2	Installation	01
8.6.3	Insulation to services	03
8.6.4	Insulation performance	05
8.6.5	Testing and commissioning	06
8.6.6	Handover requirements	07

For figure reference tables, please go to the end of each chapter.



Definitions

Dwellings	relates to self-contained units to accommodate a single household
Primary circulation	an assembly of water fittings in which water circulates between a heat source and a primary heat exchanger inside a hot water storage vessel including any space heating system
Secondary circulation	an assembly of water fittings in which water circulates in supply pipes or distributing pipes of hot water storage systems

8.6.1 Compliance

Installation and commissioning shall comply with the Technical Requirements.

8.6.2 Installation

Internal services shall not adversely affect the stability of the home and be installed to ensure satisfactory operation. Issues to be taken into account include:

- 1) fitting of pipes and cables
- 2) concealed services
- 3) stability
- 4) locating plastic pipes
- 5) jointing of pipes
- 6) fire-stopping
- 7) notching and drilling of joints.

8.6.2.1 Fitting of pipes and cables

Services should:

- comply with Chapter 5.1 'Substructure and ground-bearing floors' where they pass through the substructure
- be protected by a sleeve, or ducted, when passing through structural elements and not solidly embedded
- not be located in the cavity of an external wall, except for electricity meter tails
- not be buried in screeds unless permitted by relevant codes of practice.

8.6.2.2 Concealed services

Services concealed in walls or floors should be located so that significant cracking of the surface does not occur.

Where chases in walls are necessary, their depth should not exceed:

- 1/6 thickness of the single leaf for horizontal chases
- 1/3 thickness for vertical chases
- hollow blocks should not be chased unless specifically permitted by the manufacturer.

Where pipes are permitted in floor screeds, see figure 1 they should be:

- be protected by wrapping or ducting
- have adequate allowance for thermal expansion, particularly at changes of direction.

Figure 1: Pipes in screed

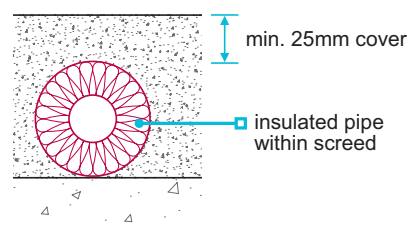

Screed cover should be a minimum of 25mm over pipes and insulating material, and:

- where pipes cross, it may be necessary to form a duct to achieve adequate cover
- for in-situ suspended concrete floors, the location and depth of pipes should be approved by the designer.

8.6.2.3 Stability

Pipes should:

- be adequately secured with suitable clips or brackets
- be installed neatly with clips spaced to prevent sagging, but not restrict thermal movement
- have adequate falls (where appropriate)
- be installed with adequate room for thermal expansion and contraction to avoid damage and noise.

8.6.2.4 Locating plastic pipes

Metallic tape should be placed behind plastic pipework, where it is concealed behind wall surfaces, and would otherwise not be located by a metal detector or similar equipment.

8.6.2.5 Jointing of pipes

Joints in pipes should be made:

- strictly in accordance with the manufacturer's instructions
- using lead-free solder and flux recommended by the pipe manufacturer, with traces removed immediately after jointing.

8.6.2.6 Fire-stopping

Fire-stopping should be provided around any services which penetrate fire-resisting floors, walls or partitions. Where a proprietary system, such as an intumescent seal is used, it should be installed in accordance with the manufacturer's instructions.

8.6.2.7 Notching and drilling of joists

Notching, drilling and chasing to accommodate service pipes and cables should either:

- comply with the Chapters below, or
- be designed by an engineer.

Solid timber and studs

Table 1: Limits for notching and drilling solid timber members

	Location	Maximum size
Notching joists up to 250mm in depth	Top edge 0.1-0.2 x span	0.15 x depth of joist
Drilling joists up to 250mm in depth	Centre line 0.25-0.4 x span	0.25 x depth of joist
Drilling studs	Centre line 0.25-0.4 x height	0.25 x depth of stud

Figure 2: Notches and holes in solid timber joists

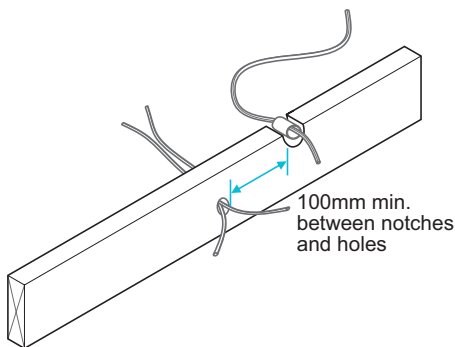
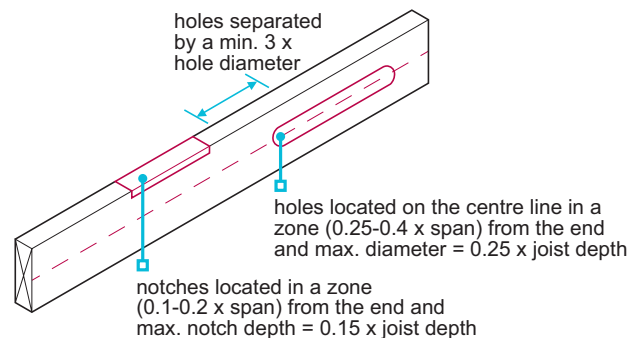

Figure 3: Notches and holes in joists safe zones



Where the structural strength is impaired by notching or drilling, the element should be replaced or correctly repaired.

Holes should be spaced at a minimum of three times the hole diameter.

Notches and holes in the same joist should be separated by a minimum horizontal distance of 100mm.

Instructions should be obtained from the designer when notching and drilling, where:

- the joist is deeper than 250mm, or
- the dimensions are not in accordance with Table 1, or
- it is close to heavy loads, such as those from partitions, cisterns, cylinders and stair trimming.

I-joists

Preformed holes are provided, and additional holes and notches should not be cut without the approval of the manufacturer.

Metal web joists

Services should run in the gaps between the metal webs. Conduits may need to be inserted before the joists are fixed in position.

Lightweight steel

Lightweight steel should be used in accordance with Chapter 6.10 'Light steel framed walls and floors'.

8.6.3 Insulation to services

Also see: Chapters 7.2.15

Insulation to internal services shall be in accordance with relevant Building Regulations and installed to minimise the effects of freezing, overheating or energy wastage. Issues to be taken into account include:

- | | |
|--------------------------------|---|
| 1) space heating and hot water | 3) systems without hot water storage |
| 2) intermediate floors | 4) systems utilising hot water storage. |

8.6.3.1 Space heating and hot water

Pipework serving space heating and hot water systems should be insulated in all areas outside of the heated building envelope. In addition, pipes should be insulated in all voids within the building envelope and within spaces which will normally be heated, if there is a possibility that those spaces might be maintained at temperatures different to those maintained in other zones.

Areas considered to be impractical to install insulation include:

- where pipes are located within the adhesive zone, behind plasterboard dry linings
- where pipes are located behind plasterboard to a brick and block construction utilising batons.

8.6.3.2 Intermediate floors

Where pipework is installed within intermediate floors they should be:

- insulated to where they transition to run behind plasterboard. For clarity the bend radius to the point within the intermediate floor would satisfy this
- insulated over the complete in length including fittings, brackets and clips.

When installing pipes through timber joists, to prevent excessive hole diameters the insulation should only be applied between each joist, the pipe should be wrapped where they pass through the joist so they can move freely and without noise.

8.6.3.3 Systems without hot water storage

Also see: Clause 8.6.3

The following pipework should be insulated:

- pipework – within a garage (outside the heated living space)
- pipework – that passes through a roof space (outside the heated living space)
- pipework that passes through an external wall cavity, that is on the cold side of the external wall insulation (outside the heated living space)
- the primary heating flow and return where they pass through an intermediate floor (void)
- flow and return pipework where they pass through an intermediate floor up to the transition point where the pipework drops to radiators below (see general provision)
- pipework should be insulated to meet the minimum requirements in 8.6.3.1.

Figure 4: Insulation to space heating systems without storage

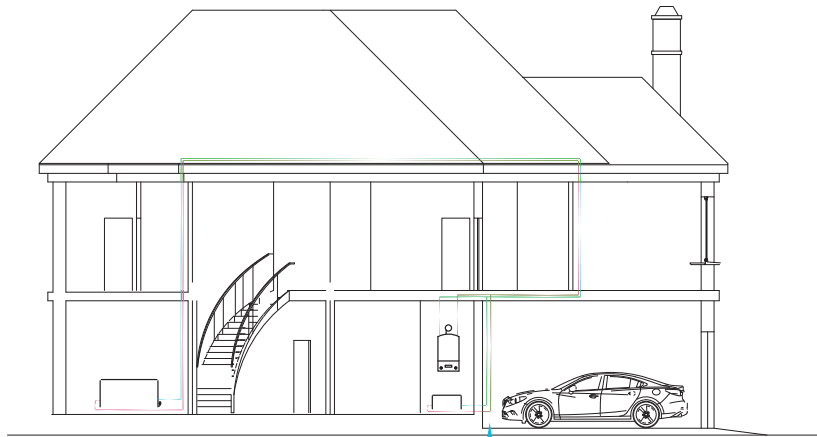

- B.** All pipe work that passes through an unheated space eg garage or pipe work that is on the cold side of wall insulation.
- B1.** Space heating flow and return where they pass through an intermediate floor.

Figure 5: Loft area

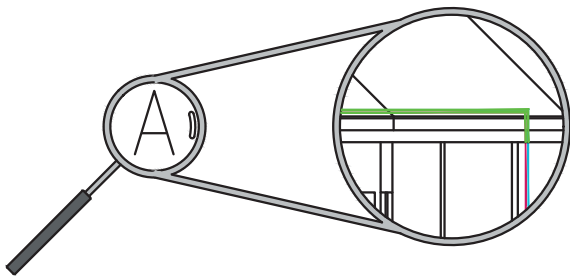
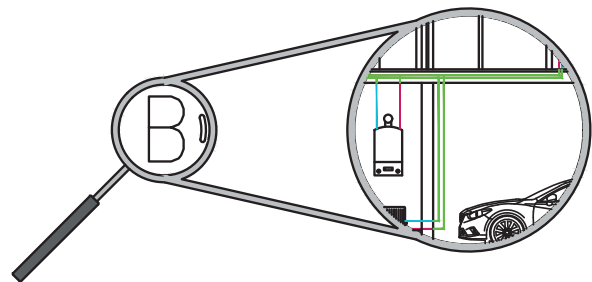

Figure 6: Garage and void area



8.6.3.4 Systems utilising hot water storage

Also see: Clause 8.6.3

The following pipework should be insulated:

- pipework within a garage (outside the heated living space)
- pipework that passes through a roof space (outside the heated living space)
- pipework that passes through an external wall void that is on the cold side of the external wall insulation (outside the heated living space)
- all hot water primary flow and return including where they pass through an intermediate floor (void)
- space heating flow and return pipework where they pass through an intermediate floor up to the transition point where the pipework drops to radiators below (see general provision)
- pipework within 1m of the hot water storage cylinder, or up to the point where they become concealed if practicable
- if secondary circulation is utilised, insulate all pipework that is kept hot by that circulation
- pipe insulation and hot water cylinders should be insulated to meet minimum requirements in 8.6.3.1.

Figure 7: Insulation to space heating systems with storage

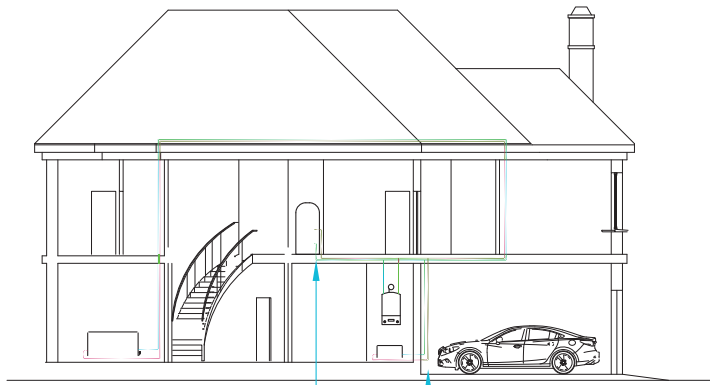

- C.** All domestic hot water primary flow and return.
- C1.** All pipe work a minimum of 1m of the hot water storage cylinder.
- B.** All pipe work that passes through an unheated space eg garage or pipe work that is on the cold side of wall insulation.
- B1.** Space heating flow and return where they pass through an intermediate floor.
- B2.** All domestic hot water primary flow and return.

Figure 10: Airing cupboard

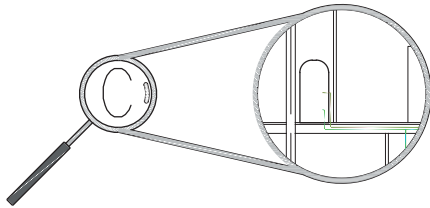

Figure 8: Loft area

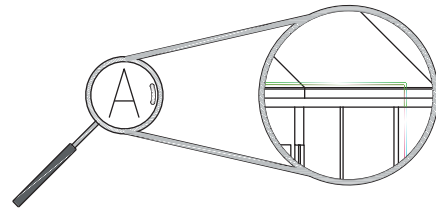
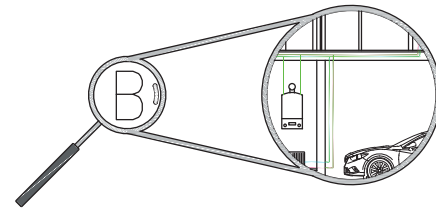

Figure 9: Garage and void area



8.6.4 Insulation performance

Insulation performance shall comply with national standards. Issues to be taken into account include:

- 1) thermal conductivity and pipe insulation size
- 2) maximum daily hot water loss for hot water storage systems.

8.6.4.1 Thermal conductivity and pipe insulation size

Minimum thickness of pipework insulation for hot water services and space heating applications using high performance insulation see table 2 below:

- all insulation used should be designed so that the permissible heat losses in BS 5422 for hot water services at 60°C are not exceeded for the different pipe sizes
- this table relates to both plastic and metal pipes.

Table 2: Pipe insulation thickness for high emissivity outer surface $\epsilon = 0.90$)

Outside diameter of pipe on which insulation thickness is based mm	Thermal conductivity at 40°C W/m/K (insulation thickness in mm)					Maximum permissible heat loss W/m
	0.025	0.03	0.035	0.04	0.045	
8	5	7	9	12	16	7.06
10	6	8	11	15	20	7.23
12	7	10	14	18	23	7.35
15	9	12	15	20	26	7.89
22	11	14	18	23	29	9.12
28	12	16	20	25	31	10.07
35	13	17	22	27	33	11.08

- for low emissivity see BS 5422 table 19A and 19B

8.6.4.2 Maximum daily hot water loss for hot water storage systems

Maximum daily heat loss for hot water storage cylinder should comply with table 3 below.

Table 3: Hot water storage heat loss

Nominal Volume (litres)	Heat loss kWh/24h
50	1.03
100	1.49
150	1.88
200	2.06
250	2.22
300	2.36
350	2.48
400	2.59
500	2.80

8.6.5 Testing and commissioning

Services and LZC technologies shall be tested and commissioned to ensure satisfactory operation. And where appropriate in accordance with the commissioning schedule.

Before completion and handover of the building services should be commissioned in accordance with relevant regulations and codes of practice.

The installer should check that the system is in accordance with the certification requirements, the manufacturer's recommendations and the design. Issues to be taken into account include:

- the safety of the system
- the correct installation of the system
- the correct operation of the system.

Upon completion, the installer should provide a certificate to confirm that the LZC technology has been installed, tested and commissioned in accordance with the above.

The commissioning engineer should ensure leaks or other defects are made good prior to the application of finish and handover of the home.

8.6.6 Handover requirements

Detailed information and instructions shall be provided to the homeowner.

The pack of information provided to the homeowner should include:

- user instructions for all systems installed
- contact details for all manufacturers of products used
- contact details for all installers of the products used
- key components installed
- a completed manufacturer's certificate from an acceptable independent assessment organisation, Benchmark, MCS, Electrical safety or suitable alternative
- details of the fuel type and source
- maintenance and servicing requirements
- warranties and/or guarantees for appliances including LZC technology
- customer information on how to use the technologies efficiently and effectively to minimise running costs
- customer information to include for solar thermal collectors how to protect from distortion if not filled with solar fluid in line with manufacturer's recommendations.

Figure reference table

Figure reference table 8.6			
Fig No	Title/Description	Clause	Page
Figure 1	Pipes in screed	8.6.2.2	1
Figure 2	Notches and holes in solid timber joists	8.6.2.7	2
Figure 3	Notches and holes in joists safe zones	8.6.2.7	2
Figure 4	Insulation to space heating systems without storage	8.6.3.3	4
Figure 5	Loft area	8.6.3.3	4
Figure 6	Garage and void area	8.6.3.3	4
Figure 7	Insulation to space heating systems with storage	8.6.3.4	5
Figure 8	Loft area	8.6.3.4	5
Figure 9	Garage and void area	8.6.3.4	5
Figure 10	Airing cupboard	8.6.3.4	5



Technical Disclaimer

The NHBC Standards are produced by NHBC as guidance solely for our builder customers as to how to interpret the technical requirements in relation to the warranty cover provided by NHBC under its Buildmark, Buildmark Choice, Buildmark Link, Buildmark Solo, Buildmark Connect or any similar product from time to time. It has not been created or intended for distribution or use outside of that purpose. The information contained in the NHBC Standards do not constitute advice and is not to be relied upon by any third party. Nothing in the NHBC Standards is intended to, nor should it be taken to, create any legal or contractual relationship. Any third party who chooses to rely upon the information contained in the NHBC Standards shall do so entirely at their own risk and NHBC accepts no duty of care or liability, however caused, in connection with its use or reliance by any third party.



Standards

2024

NHBC, NHBC House, Davy Avenue, Knowlhill, Milton Keynes, Bucks MK5 8FP

National House-Building Council (NHBC) is authorised by the Prudential Regulation Authority and regulated by the Financial Conduct Authority and the Prudential Regulation Authority in respect of carrying on its insurance business and its insurance distribution activities.

NHBC is registered in England and Wales under company number 00320784. NHBC's registered address is NHBC House, Davy Avenue, Knowlhill, Milton Keynes, Bucks, MK5 8FP. Note that only certain parts of NHBC's products and services are within the scope of UK financial services regulation. For more information on our products and services, please see our website nhbc.co.uk or your NHBC product documentation.