

## Flat roofs, terraces and balconies

This chapter gives guidance on meeting the Technical Requirements for flat roofs, terraces and balconies.

7.1.1	Compliance	02
7.1.2	Provision of information	03
7.1.3	Flat roof, terrace and balcony general design	03
7.1.4	Drainage	05
7.1.5	Flat roof, terrace and balcony structural design	07
7.1.6	Timber structure and deck	08
7.1.7	Concrete decks	11
7.1.8	Profiled self-supporting metal roof decks	12
7.1.9	Profiled self-supporting metal roofing	13
7.1.10	Thermal insulation and vapour control	15
7.1.11	Waterproofing layer and surface treatments	18
7.1.12	Green and biodiverse (brown) roofs – including roof gardens	23
7.1.13	Blue roofs	24
7.1.14	Raised podium	25
7.1.15	Detailing of flat roofs	26
7.1.16	Accessible thresholds and upstands	29
7.1.17	Metal balcony decking systems	31
7.1.18	Parapets and guarding to terraces and balconies	31

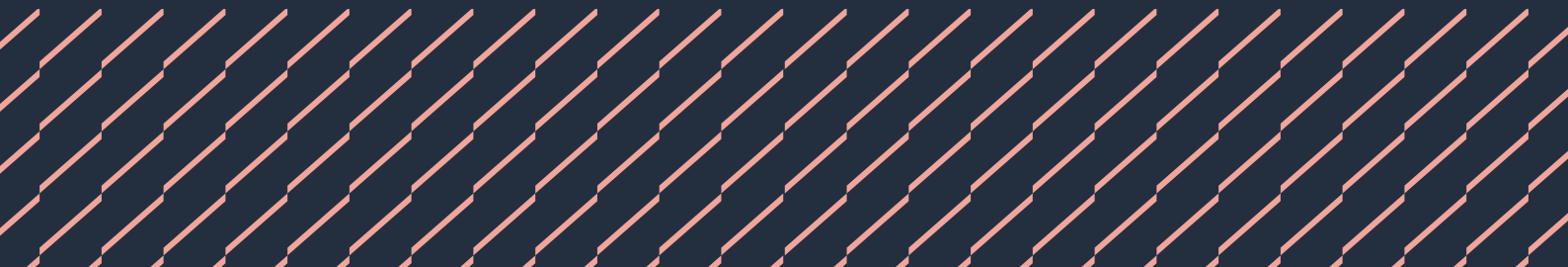

### Definitions for this chapter

For the purposes of this chapter, the following definitions apply:

<b>Air and vapour control layer (AVCL)</b>	<ul style="list-style-type: none"> <li>• Continuous layer of impermeable material to prevent the movement of air and water vapour</li> </ul>
<b>Balcony</b>	<p>Accessible external amenity platform over an open space above ground level, with direct access from a building</p> <p>Balconies may take the form of:</p> <ul style="list-style-type: none"> <li>• <b>access balcony</b> – providing pedestrian access to two or more dwellings, (sometimes referred to as a 'walkway' or 'access deck')</li> <li>• <b>enclosed</b> – protected from rain by a roof or balcony above and walls or weather screens to the sides, (sometimes referred to as a 'winter garden')</li> <li>• <b>freestanding</b> – fully, or partially, supported independent of the building structure</li> <li>• <b>inset</b> – recessed inwards from the external wall line of a building</li> <li>• <b>open</b> – has guarding but no other form of vertical enclosure</li> <li>• <b>projecting</b> – cantilevered from the external wall line of a building</li> </ul>
<b>Biodiverse (brown) roof</b>	Surface often of rubble, site excavated soil, sometimes with the inclusion of logs and rocks etc to replicate the ecology of the local area and seeded or left to self-seed
<b>Blue roof</b>	Roof installation designed for temporary attenuation of rainwater to delay entry into the urban drainage system and prevent flooding (Blue Roofs are not for water storage use)
<b>Cold roof</b>	Insulation below the deck with a ventilated void between the deck and breather membrane supported on the insulation
<b>Deck</b>	The structural substrate, including timber boarding or sheeting, profiled metal sheeting on joists/purlins or, the upper surface of in situ or pre-cast concrete and any applied screed
<b>Design fall</b>	The fall that a roof should be designed at to accommodate initial and long-term deflection and achieve at least the required 'finished fall' in use. The 'Design fall' is normal taken as twice the 'Finished fall'
<b>Finished fall</b>	The minimum fall that should be achieved on the waterproofing layer once the roof has been installed and fully loaded
<b>Firring</b>	A tapered batten which creates a fall to a timber deck
<b>Flat roof</b>	A roof with a maximum slope of 10 degrees from the horizontal
<b>Flat roof build-up</b>	The roof components above the deck including, as applicable, AVCL, insulation, waterproofing layer, and surface finish/topping
<b>Fully supported hard metal roofing</b>	Flat hard metal sheeting forming the weather skin and fully supported on a deck
<b>Fully supported soft metal roofing</b>	Soft metal sheeting (lead) forming the weather skin and fully supported on a deck
<b>Green roof - extensive</b>	Roof topping of a shallow growing medium supporting plants such as sedums, grasses, wildflower species etc. Generally low maintenance and access for maintenance only
<b>Green roof - intensive</b>	Roof topping of a growing medium to support trees, shrubs, lawns etc and may include hard landscaping, and used as an amenity space (sometimes referred to as a Roof Garden)
<b>Interstitial condensation</b>	Condensation that occurs within or between layers of construction
<b>Inverted warm roof</b>	A roof with Insulation placed directly above the waterproofing layer
<b>Paving/Decking</b>	A protection layer on which people walk, above the waterproofing layer, on a balcony or terrace
<b>Profiled self-supporting metal deck</b>	Profiled metal deck, spanning between structural supports eg purlins, and supporting the flat roof build-up
<b>Profiled self-supporting metal roofing</b>	Profiled metal sheeting forming the weather skin and spanning between structural supports eg purlins
<b>Terrace</b>	<p>External surface for amenity use, above an internal space, above ground level and with direct access from a building. For waterproofing and thermal purposes, a terrace is treated as a flat roof.</p> <p>Terraces may take the form of:</p> <ul style="list-style-type: none"> <li>• <b>access terrace</b> – providing pedestrian access to two or more dwellings (sometimes referred to as a 'walkway' or 'access deck')</li> <li>• <b>buried podium</b> is a roof structure at, or below, ground level with hard and/or soft landscaping and sometimes vehicular access for emergency vehicles or parking. Waterproofing to the podium is linked to the tanking of the basement structure below, as described in Chapter 5.4</li> <li>• <b>private terrace</b> – for the use of a single dwelling</li> <li>• <b>raised podium</b> – a terrace, other than an access terrace, above ground level, over a non-habitable area(s) such as a car park or plant room(s). The podium itself may provide hard and/or soft landscaped amenity areas</li> </ul>

<b>Upstand</b>	Perimeter Waterproofing to provide continuity between a flat roof or deck and adjoining vertical wall construction. The minimum upstand height is normally 150mm unless serving an accessible threshold where this height may be reduced to 75mm
<b>Warm roof</b>	A roof with Insulation placed directly below the waterproofing layer
<b>Water flow reducing layer (WFRL)</b>	A vapour permeable loose laid layer, resistant to water, UV, and rot, used to reduce the flow of water and fines into the insulation layer in an inverted warm roof system
<b>Waterproofing layer</b>	Layer of impermeable flexible material forming the primary barrier to water ingress
<b>Zero fall roofs</b>	Roofs with a finished slope which lies between 0 and 1:80 and which achieve a finished drained surface that has no back falls or ponding

## 7.1.1 Compliance

Also see: Chapter 2.1

### Flat roofs, terraces and balconies shall comply with the Technical Requirements.

Flat roofs, terraces and balconies which comply with the guidance in this chapter will generally be acceptable to NHBC.

Other sources of information include:

- BS 6229 Flat roofs with continuously supported flexible waterproof coverings. Code of practice
- BS 8579 Guide to the design of balconies and terraces
- BS 8217 Reinforced bitumen membranes for roofing. Code of practice
- BS 8218 Code of practice for mastic asphalt roofing
- BS 8747 Reinforced bitumen membranes for roofing
- BS 5250 Code of practice for control of condensation in buildings
- BS 5427 Code of practice for the use of profiled sheet for roof and wall cladding on buildings
- BS 6915 Design and construction of fully supported lead sheet roof and wall coverings. Code of practice
- BS EN 507 Roofing products from metal sheet – Specification for fully supported roofing products of aluminium sheet
- BS EN 1090-4 Execution of steel structures and aluminium structures. Technical requirements for cold-formed structural steel elements and cold-formed structures for roof, ceiling, floor and wall applications
- BS EN 12056 Gravity Drainage Systems inside buildings. Part 3 Roof drainage, layout and calculation
- BS 8490 Guide to siphonic roof drainage systems
- BS 8204 Screeds, bases and in situ floorings
- CIRIA C753 SuDS Manual 2015
- National Federation of Roofing Contractors (NFRC) – eg NFRC Technical Guidance Note for Construction and Design of Blue Roofs. Roofs and podiums with controlled temporary water attenuation
- Mastic Asphalt Council (MAC) Mastic asphalt – The technical guide
- Single Ply Roofing Association (SPRA) Single Ply: Design Guide
- Federation of Traditional Metal Roofing Contractors (FTMRC) 'UK Guide to Good Practice – 3rd edition'
- Lead Contractors Association 'Lead Sheet in Roofing. The Ultimate Guide to Best Practice'
- Lead Sheet Training Academy 'The complete manual'
- The GRO Green roof code of practice for the UK
- The Green Roof Organisation GRO fire risk guidance document
- Roofing and Waterproofing Test Association (RAWTA)
- Liquid Roofing and Waterproofing Association (LRWA) Code of Practice Specification and Use of Liquid Applied Waterproofing systems for Roofs, Balconies and Walkways
- Siphonic Roof Drainage Association (SRDA) A guide to Siphonic Roof Drainage
- Metal Cladding and Roofing Manufacturers Association (MCRMA).

Where a flat roof or terrace is above another home, it should provide satisfactory acoustic performance in accordance with relevant Building Regulations.

Where applicable, flat roofs, balconies and terraces should meet the relevant fire protection requirements in accordance with relevant Building Regulations.

### 7.1.2 Provision of information

**Designs and specifications shall be produced in a clear understandable format, include all relevant information and be distributed to all appropriate personnel.**

Design and specification information should be issued to NHBC, site supervisors, relevant specialist subcontractors and suppliers, and include the following:

- design and details for balcony construction including the decking and drainage system
- extent and direction of falls, and position of outlets to provide effective drainage with no back falls. A roof deflection analysis should be provided for medium to large roofs and those with complex roof layouts
- sections through the construction, including how falls are formed
- method of ventilating voids where ventilation is required.
- size, specification and position of the components, including treatment for durability and the position and extent of the air and vapour control layer, insulation and waterproofing layers
- details at critical junctions
- details of fixings, their frequency and fixing method, including those for insulation and surfacing
- specification for intensive and extensive green roofs, biodiverse roofs, or Blue roofs
- details and fixing methods of balcony support and guarding components
- survey requirements and preparation treatment of deck before application of waterproofing
- method of testing the integrity of the waterproofing layer.

### 7.1.3 Flat roof, terrace and balcony general design

**The flat roof, terrace and balcony construction should suit the design and intended use.**

The design of the flat roof, terrace (including podiums), or balcony, should adopt one or more of the following forms of construction.

Note  
The suitability of any combination of deck, insulation, blue roof attenuation, and roof toppings, will depend on the structural loadings and the capability of the deck and insulation to safely support those loads in accordance with the Structural Engineer's design.

#### Individual Elements

##### Solid RC Deck

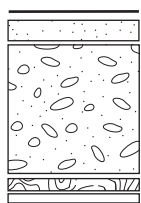

##### Composite RC deck

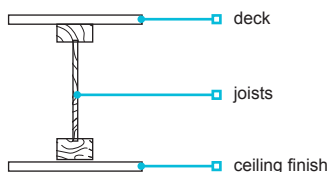
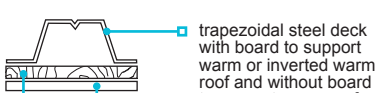
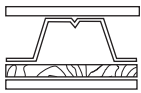
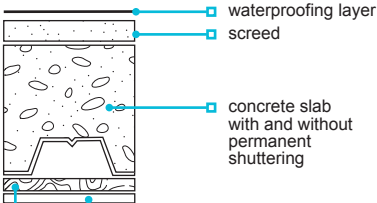

##### Warm roof

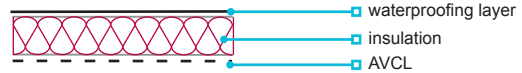

##### Cold roof

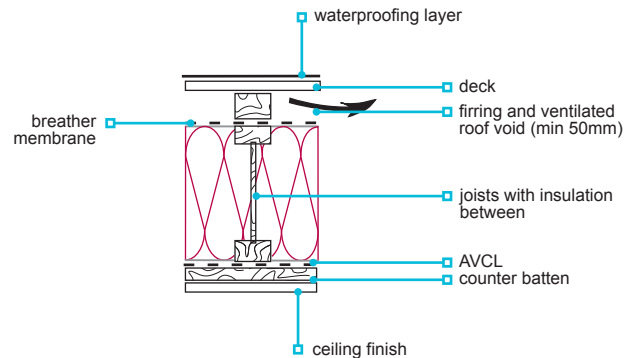

##### Inverted warm roof



Roof toppings

Green Roofs

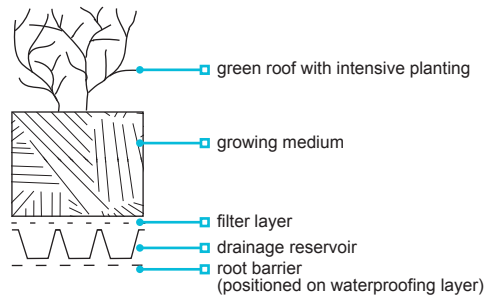
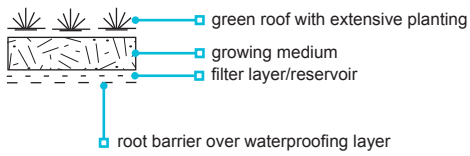

Paved Roof

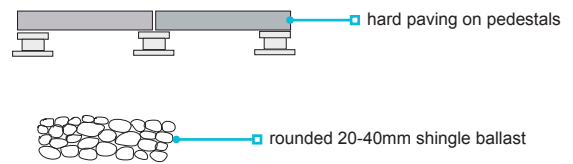
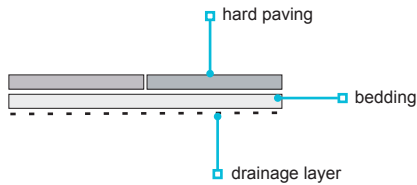

Roof, terrace, and balcony constructions using the individual elements

Uninsulated decks

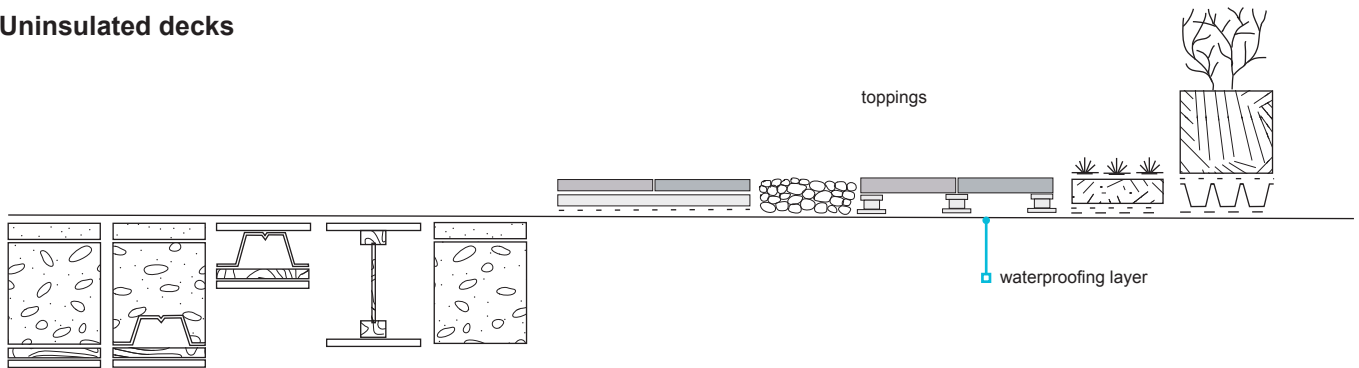

Warm roof construction

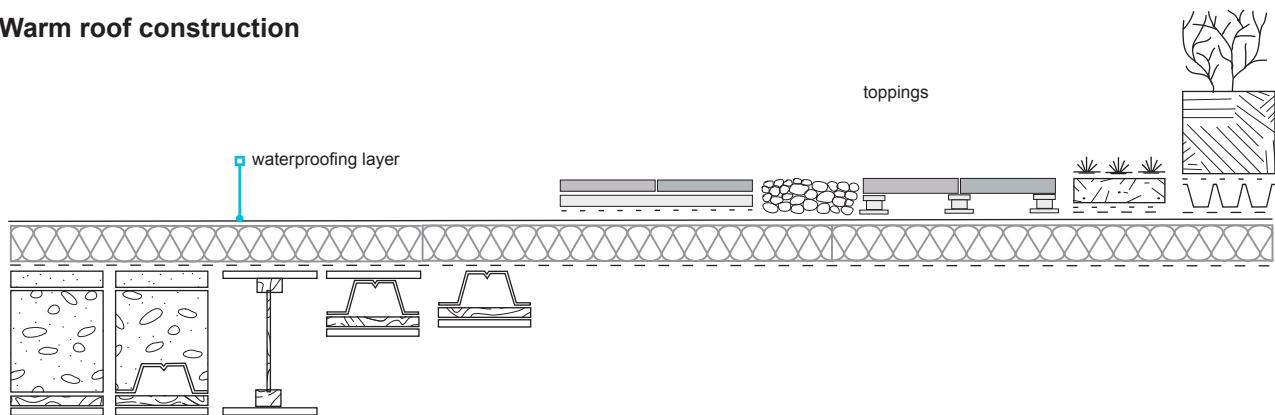

Inverted warm roof construction

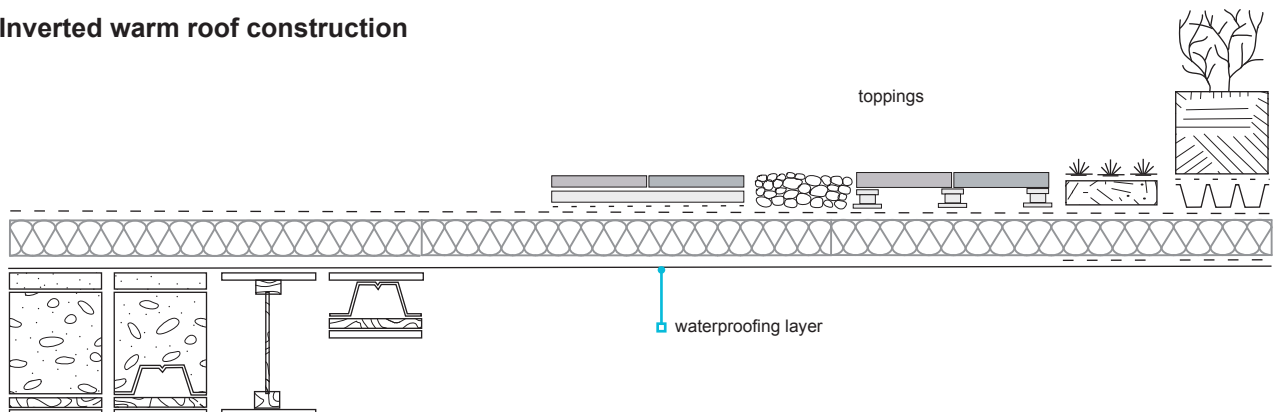

### Cold roof construction

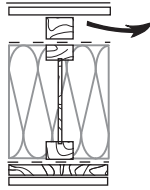

### Blue roof make up

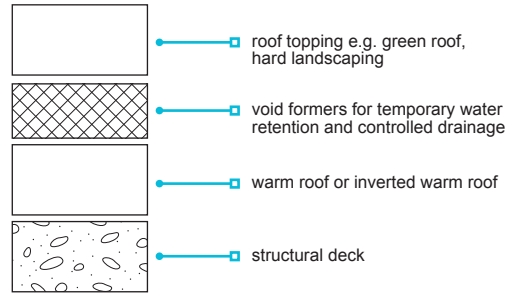

## 7.1.4 Drainage

**Flat roofs, balconies and terraces shall have adequate and effective rainwater drainage to a suitable outfall. Issues to be considered include:**

- a) drainage system
- b) falls
- c) zero fall roofs
- d) deck survey.

### Drainage system

The rainwater drainage system may be based on conventional piped drainage or an edge drained design. In all cases the downpipes, overflows and edge drainage outlets should be positioned in the construction to provide effective drainage that will not cause water to flow directly down onto the walls and fascia surfaces below or barrier edges of balconies installed in any stacked multi-storey arrangement.

A drainage system of outlets and downpipes should be:

- provided to all flat roof, balcony and terrace areas
- of sufficient size to accommodate normal rainfall and sized to cope with concentrated flows including the accumulative effect of one roof draining on to another
- fixed in accordance with the design and supported and jointed in accordance with the manufacturer's recommendations
- installed ensuring any gutters, including box gutters, are provided with stop ends where applicable, and with sufficient falls to provide effective drainage to outlets/downpipes
- provided with overflow(s) to avoid flooding in the event of one or more drainage outlets becoming blocked
- designed with a projecting profile that prevents rainwater from either tracking back into any soffit or running straight down onto vertical surfaces situated below
- designed with a downpipe shoe fitted where any downpipe outlet discharges above finished ground level, including above a drainage gulley.

Designs for drainage of balconies and terraces should follow BS 8579 guidance for the provision of discharge outlets with effective clearance, capacity and profile shape to throw rainwater clear of the edge and prevent residual dripping onto other parts of the building beneath.

A design approach for free draining balconies can be accepted if rainwater will always be routed away from the building to drain via a suitably formed soffit drainage tray that directs water to run outwards over a continuous formed perimeter edge. But where this drainage design is installed for stacked balconies on multi-storey elevations - the rainwater will tend to cascade down from these edge drainage slots as water runs off each balcony.

Under typical wind driven rainstorm conditions the water runoff volumes from these balcony catchment surfaces will progressively increase in a downward direction until the full volume of water reaches ground level. This can adversely affect locations such as main entrances to apartment buildings as well as any access doorways and private gardens of individual homes situated at ground level. Therefore, in addition to the free draining balcony design there is a requirement for design of ground level drainage to effectively prevent ponding or flooding of water. This drainage design is required along all building perimeter locations where thresholds, access locations and other places of regular use will exist.

Rainwater outlets should:

- be of the size and number required to deal with the expected rainfall intensity in accordance with BS EN 12056-3
- be positioned to provide effective drainage to all areas of the roof
- be recessed to facilitate the free flow of water without forming ponding at the junction with the waterproofing layer
- be accessible for maintenance
- be insulated to avoid surface condensation on the outlet and downpipe if passing through habitable areas.

Where a flat roof, balcony or terrace has an upstand on all sides, drainage should consist of a minimum of two outlets connected to separate downpipes, or one outlet plus an overflow.

The overflow should be:

- provided through parapet walls or perimeter upstands
- sized for effective Flow rate and positioned to prevent water from entering the building, particularly in relation to door thresholds and low windowsills
- of higher capacity than the combined capacity of the other outlet(s)
- positioned to discharge safely away from the building
- be visible when in operation.

### Falls

The finished roof, balcony or terrace should have effective drainage to the outlet(s) without creating back falls or ponding on the waterproofing layer and WFRL where fitted.

For medium to large, and complex roof layouts and roofs where the 'design fall', as shown in Table 2, is not used for the design, a detailed analysis should be undertaken to establish overall and local deflection, under load and long-term creep, and direction of falls. Allowances should be included for workmanship and construction tolerances particularly with steel frame erection tolerances. The effects of localised loadings from features such as planters, service equipment, etc should be included in the design.

The design should show how ponding will be avoided, eg by placing outlets at points of maximum deflection, by use of a screed, use of tapered insulation, or firrings, to take out the deflection and form falls to outlets.

Where falls are formed by use of screeds follow the guidance in clause 7.1.8.

Where tapered insulation is used:

- drainage should be designed by the insulation manufacturer, with 'design' falls of no less than 1:60
- installation should comply with the design and manufacturer's recommendations
- the sequence of installation should ensure that boards are waterproofed, and the roof sealed at the end of each day, or before the arrival of inclement weather
- it should be installed directly onto the air and vapour control layer, with the primary waterproofing layer above
- changes in the direction of falls should be formed with mitred joints
- successive roof layers should be installed with a minimum of delay, to avoid trapping water during construction.

Firring pieces should be:

- used to form falls, unless the design specifies a sloping joist or ceiling
- of the size given in Table 1 where installed across the joists
- adequately fixed to the joists in accordance with the design.

**Table 1:** Size of firring pieces used to form falls

Joist centres (mm)	Minimum width (mm)	Minimum depth (mm)
400 or 450	38	38
600	38	50

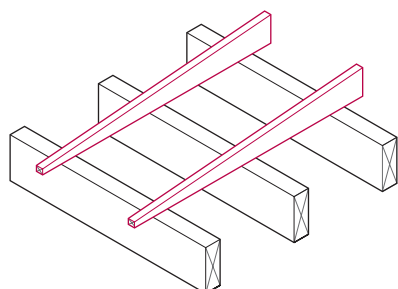

Solid or engineered joists  
Firrings fixed perpendicular to joists

Where a detailed analysis is not undertaken the roof should be designed with a 'design fall' that caters for initial and long-term deflection to ensure the 'finished fall' provides effective drainage without back falls or ponding.

**Table 2:** Suggested 'Design' falls for various roof types

Type of roof	Design fall	Minimum finished fall
Membrane and liquid applied waterproofing	1:40 <sup>3</sup>	1:80
Profiled metal roof system (self-supporting)	5.5° (1:10) <sup>1</sup>	4° (1:14) <sup>2</sup>
Profiled metal roof (fully supported)	6.5° (1:9)	5° (1:12) <sup>4</sup>
Standing seam roof system (self-supporting)	2.5° (1:23) <sup>1</sup>	1° (1:60) <sup>4</sup>
Flat sheet hard metal roof (fully supported)	1:40 <sup>3</sup>	5° (1:12) <sup>4</sup>
Lead roof (fully supported)	1:40 <sup>3</sup>	1:80
Green/biodiverse roof	1:40 <sup>3</sup>	1:80 (at drainage level)
Blue roof	1:40 <sup>3</sup>	1:80 (see also Zero fall roofs)
Tapered insulation	1:60 <sup>3</sup>	1:80

**Notes**

- 1 The supporting structure should be designed at a pitch of 1.5° more than the minimum pitch for the sheeting, or the designed roof slope, to allow for tolerances and onsite variations, unless justified by a detailed structural analysis of the main frame and secondary steelwork to account for deflection/settlement.
- 2 Based on through fixings. For lesser pitches, including the apex of any curved roof which approaches flat, proprietary secret fixed types of profiled sheeting should be used in accordance with the system manufacturer's instructions.
- 3 'design fall' to take account of deflection and construction tolerance for the supporting deck to ensure at least minimum finished fall on completed roof. 'Design fall' usually taken as twice the 'finished fall' unless a detailed deflection/settlement of the deck is carried out.
- 4 Check with manufacturer for alternative pitch recommendations.

**Zero fall roofs**

Zero falls are not accepted for roofs with exposed waterproofing layers, such roofs should be designed to the falls shown in Table 2.

**Deck Survey**

Prior to laying the waterproofing layer(s) a site survey of the deck should be carried out by the deck erector and any back falls should be addressed. Depending on the deck material this may be achieved by applying localised screed, to remove the depression and create falls to outlets, the adjusted areas should be resurveyed to ensure no back falls remain, or by providing additional rainwater outlets at the point(s) of maximum deflection. A formal handover procedure should be undertaken between the deck erector and the waterproofing contractor.

**7.1.5 Flat roof, terrace and balcony structural design**

**Flat roofs, terraces and balconies shall support and transmit loads safely to the structure.**

The structure of the flat roof, terrace or balcony should:

- be produced by an engineer in accordance with Technical Requirement R5, and BS EN 1991-1-1, BS EN 1991-1-3, BS EN 1991-1-4 and BS 8579: 2020 for balconies
- be designed to address both short term and long-term deflection to provide an effective drainage strategy with no back falls or ponding
- resist wind uplift by self-weight or by being anchored to the main structure – where required, holding down straps should be provided at maximum 2m centres at the perimeters
- have adequate provision for the additional loads where a flat roof is to act as a terrace, roof garden, for support of permanent service equipment, and for additional loads during construction
- have adequate provision for movement in larger roofs particularly where the span of the roof deck changes. Eg in L-Shaped buildings; joints should be continuous through the vertical upstands, walls and edges of the building
- include support steelwork and joists which are square, true and free from twists or sagging
- have adequate crack control/dimensional stability to avoid damage to directly applied AVCL and waterproofing layer, particularly liquid applied waterproofing.

Where joists and concrete roof elements are used to provide lateral restraint, they should:

- have a minimum bearing of 90mm, or
- have restraint straps at 2m centres (maximum) where joists or concrete beams are parallel to walls.

### 7.1.6 Timber structure and deck

**Timber flat roofs, balconies and terraces shall be of adequate strength and durability and be installed to form a satisfactory substrate for the waterproofing system. Issues to be considered include:**

- a) structure and durability
- b) joist hangers, straps and strutting
- c) installing timber decks.

#### Structure and durability

Structural elements of balconies should have a service life of at least 60 years.

Timber in balconies should be limited to elements which are supported by materials other than timber. Timber should not be used for:

- gallows brackets supporting a balcony
- posts or columns supporting a balcony
- guardrails including their support
- infill joists
- cantilevered joists or decks.

Decking boards should be specified and fixed in accordance with:

- guidance from the Timber Decking and Cladding Association, or
- an engineer's design, in accordance with Technical Requirement R5.

The use of timber in balcony and terrace constructions may also be restricted by fire protection requirements set out in the Building Regulations.

Timber, including solid and engineered joists, should be:

- checked for conformity with the design upon delivery
- rejected where excessively wet, damaged or not of a suitable quality or shape
- stored under cover to prevent wetting but avoid sweating
- preservative treated or naturally durable, in accordance with Chapter 3.3 'Timber preservation (natural solid timber)'
- retreated along the cut edges with a coloured preservative, where preservative treated timber has been cut
- be temporarily covered to prevent wetting, unless the waterproofing is to be installed immediately.

Timber structure should:

- be in accordance BSEN 1995-1-1 or appropriate load/span table published by TRADA in support of building regulations
- be from regularised timber, dry graded to BS 4978 and marked 'DRY' or 'KD' where softwood is used internally
- have I-joists or metal web joists specified in accordance with the manufacturer's recommendations and not used where any part of the joists is exposed to external conditions
- have joists which are sized and spaced in accordance with the design and at maximum 600mm centres
- be level and, where necessary, using hard packing such as tiles or slates bedded in mortar to adjust joists (loose or soft packing, including timber, should not be used)

Timber decks should be formed from one of the materials listed in Tables 3, 4 and 5.

**Table 3:** Materials used for deck to flexible membrane roof coverings

Material	Minimum thickness of deck (mm) <sup>1</sup>	
	450mm joist centres	600mm joist centres
Plywood board to BS EN 636, Use Class 3.2, 'S', <sup>2</sup>	15 <sup>4</sup>	18 <sup>4</sup>
Oriented strand board, to BS EN 300 type OSB3	15	18
Pre-treated timber planking, tongue and grooved (close boarded timber). Maximum plank width 100mm <sup>3</sup>	19	19

**Notes**

- 1 Thickness of deck may need to be thicker to resist pull-out forces on fixings.
- 2 All square board edges to be supported.
- 3 Moisture content between 16-20% at time of fixing.
- 4 For curved roofs two layers of thinner boards to achieve min thickness.

**Table 4:** Materials used for deck for fully supported traditional hard metal roof coverings

Material	Minimum thickness of deck (mm)
Plywood board to BS EN 636, Class 3.2, 'S' <sup>1</sup> square edged with 2-3mm gaps between boards <sup>3</sup>	18 <sup>2</sup>
Pre-treated timber square edged sarking boards, width 100-125mm with 3-5mm gaps between <sup>4</sup>	18

**Notes**

- 1 Avoid yellow and maritime pine or low-quality softwoods.
- 2 For curved roofs two layers of thinner boards to achieve min 18mm thickness.
- 3 All board edges to be supported.
- 4 Moisture content between 16-20% at time of fixing.

**Table 5:** Materials used for deck to lead roof coverings

Material	Minimum thickness of deck (mm)
Plywood board to BS EN 636, Class 3.2 'S' <sup>1</sup> square edged with 3-5mm gaps between boards <sup>3</sup>	18 <sup>2</sup>
Pre-treated softwood timber square edged sarking boards, width 100-125mm with 2-3mm gaps between <sup>4</sup>	18

**Notes**

- 1 Avoid oak, Douglas fir and western red cedar.
- 2 For curved roofs two layers of thinner boards to achieve min 18mm thickness.
- 3 All board edges to be supported.
- 4 Moisture content between 16-20% at time of fixing.

### Joists hangers, straps and strutting

Masonry carrying joist hangers should be level and at the correct height.

Mild steel straps and fixings should be protected against corrosion in accordance with BS EN 845-1.

Joist hangers should be:

- in accordance with BS EN 845
- the correct size for the timber joist or trimmer
- fixed in accordance with the design.

Where holding-down straps are required to prevent the roof from lifting from the supporting structural, they should be:

- spaced at a maximum of 2m centres at the perimeters
- fixed with minimum of four hardened nails 4mm in diameter x 75mm long, or No 12 wood screws x 50mm long, into plugs (where fixed to masonry)
- fixed with the lowest fixing secured within 150mm of the bottom of the vertical strap
- 30mm x 2.5mm and 1m long
- predrilled for fixings.

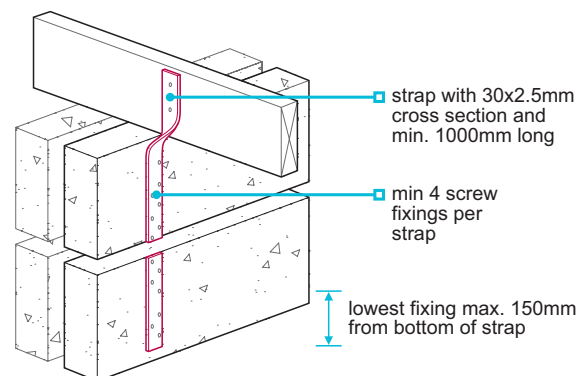
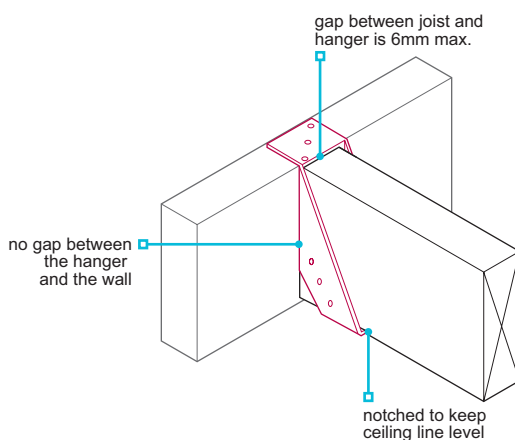

Strutting should be provided to prevent excessive movement, and:

- be either herringbone type (timber 38mm x 38mm), solid blocking (38mm thick timber x 0.75 depth of joist) or proprietary steel strutting or I-joist sections
- not prevent cross ventilation in cold roofs
- spaced in accordance with Table 6.

**Table 6:** Spacing for strutting

Joist span (m)	Rows of strutting
Up to 2.5	None needed
2.5 – 4.5	One (at centre of span)
Over 4.5	Equally spaced along the span at maximum 2.5m centres

### Installing timber decks

When installing timber decks:

- conditions should be dry, and materials protected from wetting until the roof is complete
- the area of deck installed should be of a size which can be quickly covered in the event of rain
- materials that have been damaged or adversely affected by moisture should be discarded
- tops of boards should be laid flush with no deviation greater than 2mm
- boards should be laid in a staggered pattern
- cut edges should be treated to prevent moisture ingress
- should have a minimum 'good one side'
- should have all nails and screws punched or countersunk below the surface of the board
- should be free of sharp arises on external angles.

Plywood and oriented strand board (OSB) should:

- have tongued and grooved boards installed with the long edges at right angles to the supporting firrings or joists, and short edges supported on a joist or noggling. Note: use square edge boards for support of hard metal and lead roofs
- have edges of square edged boards supported on joists or noggings with movement gaps of 3-5mm between boards
- have a minimum movement gap of 10mm (or 2mm per metre of boarding whichever is the greater) where boards abut a rigid upstand
- be supported on noggings where the edges of boards situated along the roof perimeter do not coincide with joists, and where square edged boards within the roof area do not coincide with a joist
- be fixed at a maximum of 100mm centres (unless the design specifies closer)
- be fixed with flat-headed ring shank nails (minimum of 50mm long x 3mm for plywood, minimum of 3mm x 2.5 x board thickness for OSB) or screws of at least the same length.

OSB should be:

- installed over supports in the direction indicated on the boards, with the stronger axis installed at right angles to the supporting joists
- fixed a minimum of 8mm from the edge of the board.

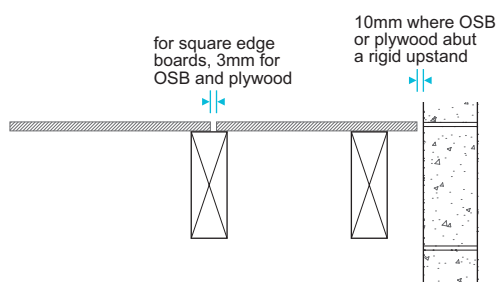

Softwood tongued and grooved boarding should be:

- closely clamped together with end joints staggered,
- fixed with two ring shank nails to each joist or furring, with nail heads punched below the timber surface.

### Cross Laminated Timber (CLT)

Due to the semi-impervious nature of CLT panels and the risk of trapping moisture in the panels during the construction period, CLT panels are not accepted for flat roof construction.

### Structural insulated panels (SIPs) (used as self-supported deck)

Due to the difficulty in applying an effective AVCL to the warm side of a SIPs panel to prevent water vapour entering the panel, and the risk of trapping moisture in the panels during the construction period, SIPs panels are not accepted for warm flat roof construction.

## 7.1.7 Concrete decks

Concrete flat roofs and balconies shall form a satisfactory substrate for the waterproofing systems.

Issues to be considered include:

- a) structure and durability
- b) screeds to falls
- c) drying.

### Structure and durability

Concrete flat roofs should be constructed to ensure they achieve the required design, strength and durability, and be in accordance with BS EN 1992-1-1 and Chapter 3.1 'Concrete and its reinforcement'.

In-situ reinforced concrete decks should:

- be formed using a mix which has low shrinkage characteristics
- have accurately constructed and suitably supported formwork
- have an even surface to receive the selected waterproofing layer (with adhesive bonded membranes the surface should be slightly roughened, wooden floated or lightly brushed, in accordance with the manufacturer's recommendations).
- be protected until adequately cured and dried
- not contain additives that could affect the adhesion of any adhesive bonded waterproofing membranes.

#### Note

Liquids applied surface treatment onto the concrete to assist curing can adversely affect the bonding of the waterproofing layer. The compatibility of such liquids should be checked with the waterproofing layer manufacturer before use.

Precast concrete decks should:

- have a minimum 90mm bearing (unless the design specifies a smaller dimension)
- have allowance for continuity or anti-crack reinforcement to avoid differential movement between units and stress in waterproofing layer
- have allowance for movement approximately every 15m and at abutments
- be installed to provide an even surface with no back falls
- be grouted, as specified in the design.

### Screeds to falls

Where falls have not been formed in the concrete deck, falls may be formed by the application of a screed. Sand/cement screeds used to form falls to concrete roofs should be:

- free from ridges and indentations
- laid on a concrete deck that has been suitably prepared to receive a screed
- finished with a wooden float to provide a smooth, even surface for the air and vapour control layer and waterproofing finish
- to a minimum thickness in Table 7 where a cement/sand screed 1:4 (cement:sand) is used
- suitably dry and primed to receive the waterproofing system in accordance with the membrane manufacturer's recommendations.

Lightweight screed should only be installed by specialist contractors and have a topping of 1:6 (cement:sand) 15mm thick.

**Table 7:** Minimum screed thicknesses

Location of screed	Nominal thickness (mm)
Bonded monolithically to in-situ or separate bonded to precast concrete <sup>1</sup>	40 (25 minimum)
Unbonded on separating layer	70 (50 minimum)
Proprietary polymer modified screeds	In accordance with manufacturer's recommendations

#### Notes

- 1 Precast units should be sufficiently rigid and properly grouted to avoid movement between units leading to cracking in the bonded screed. Movement joints/details may be required over ends of precast units and at perimeters or abutments. The waterproofing layer detailing should take account of any movement joints.
- 2 Where a cast in situ concrete deck, designed and laid to falls, is found to have areas of ponding or back falls preparation work should be carried out to provide effective drainage prior to the application of the waterproofing layer. Polymer modified screeds may be used to make up any depressions in the concrete roof to avoid any ponding or correct any back falls. The adjusted areas should be resurveyed to ensure no ponding or back falls remain. The compatibility of the levelling screed with the waterproofing layer should be confirmed by the waterproofing manufacturer.

## Drying

Permanent waterproofing layer should not be installed until the deck has cured and dried sufficiently to avoid trapping potentially damaging moisture and to allow the application of the waterproofing in accordance with the membrane manufacturer's recommendations. A check should be carried out on the moisture content of the slab to meet the membrane manufacturer's recommendations. Where an adhesive bonded waterproofing layer is to be applied an adhesive bond test should be undertaken to check whether the concrete is sufficiently dry to achieve the correct bond, (usually around 28 days for fully bonded waterproofing or to manufacturer's recommendations).

**Note**  
Permanent metal shuttering will significantly prolong the period needed to achieve an acceptable moisture content of the concrete before applying any waterproofing layer. Perforated shuttering can assist drying out, any perforation should be factory made. Mechanical extraction/dehumidifier can also assist in the drying process.

### 7.1.8 Profiled self-supporting metal roof decks

**Profiled self-supporting metal decks shall form a satisfactory substrate for the flat roof build-up. Issues to be taken into account include:**

- a) structural performance
- b) material and profile
- c) roof build-up.

#### Structural performance

Profiled self-supporting metal flat roofs should:

- be constructed to ensure they achieve the required strength and durability, and be checked for conformity with the design upon delivery
- comply with the manufacturer's load and span tables and the relevant applied safety factor
- conform to BS EN 1090-4 (steel) and BS EN 1090-5 (aluminium) and resist loads in accordance with BS EN 1991-1-1,3 & 4 and be fixed in accordance with the manufacturer's instructions
- be side lap stitched to ensure it performs as a continuous plane layer (unless the manufacturer recommends otherwise)
- be adequately protected from construction loads
- be suitably stored to prevent damage.

#### Material and profile

Profiled self-supporting metal flat roof sheeting should:

- be galvanised steel to BS EN 10346 (typical gauge range 0.7-1.2mm) or aluminium to BS EN 485-2 (minimum gauge 0.9mm) and used in accordance with BS EN 1993-1-3 and BS EN 1999-1-4 respectively
- have a crown which is a minimum of 45% of the profile width (for bonded systems) (not including the crown stiffener grooves)
- have a crown which is minimum of 40% of the profile width (for mechanically fixed systems)
- be of suitable quality and finish before the waterproofing layer and insulation system is installed
- be fixed using suitable fixings which avoid bimetallic corrosion in accordance with the manufacturer's recommendations.

#### Roof build-up

The roof build-up should:

- be a 'warm' or 'inverted warm' roof design
- have drainage falls formed by installing the profiled metal sheeting at a slope or by use of tapered insulation
- use insulation board with a compressive strength capable of spanning across the troughs of the profiled sheeting without crushing or be laid on a support board fixed across the profiles
- use a reinforced air and vapour control layer, or AVCL recommended by waterproofing manufacturer, in warm roof build-ups where unsupported across the troughs
- incorporate a support board fixed profiles in inverted warm designs to fully support the waterproofing layer.

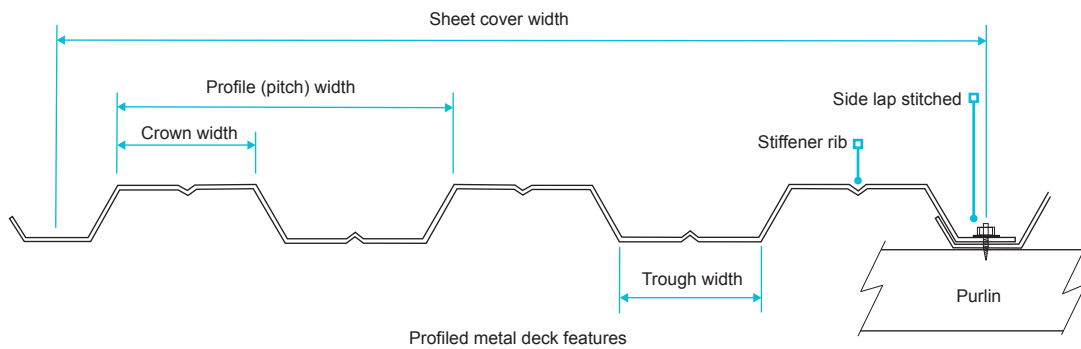

### Warm roof construction – with metal deck

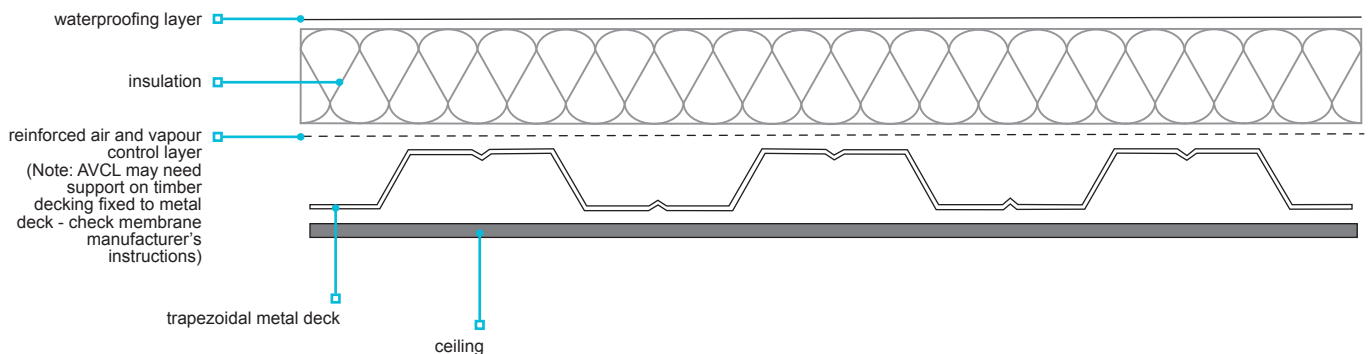

### Inverted warm roof construction

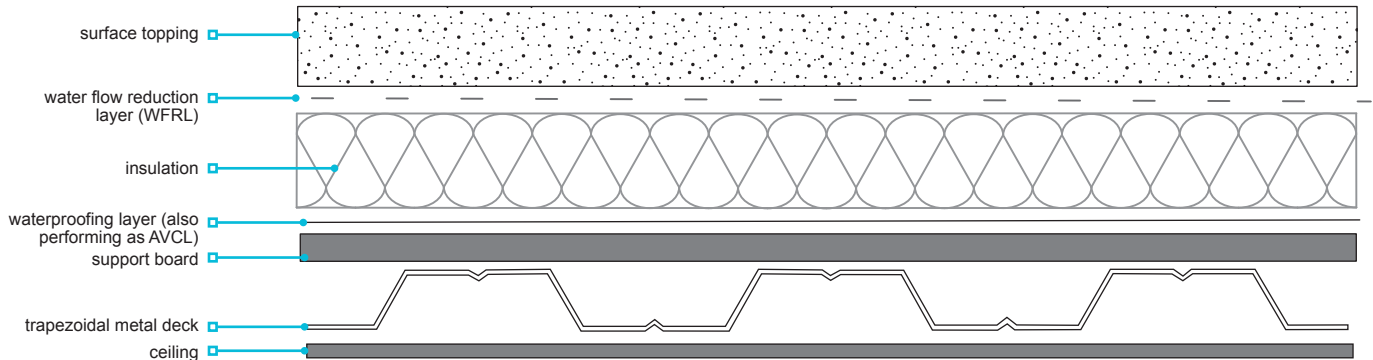

## 7.1.9 Profiled self-supporting metal roofing

**Profiled self-supporting metal roofing shall be of adequate strength and durability, and resist the passage of water to the inside of the building, and provide an adequate level of thermal and sound insulation.**

Profiled self-supporting metal sheet roofs should be designed and constructed in accordance with:

- BS 5427 CoP for the use of profiled sheet for roof and wall cladding
- BS EN 14782 Self-supporting metal sheet for roofing, external cladding and internal lining. Product specification and requirements
- BS EN 14509 Self-supporting double skin metal faced insulating panels – Factory made products – Specification
- BS EN 508- parts 1,2 and 3 Roof and cladding products from metal sheet. Specification for self-supporting products of steel, aluminium or stainless steel
- BS EN 506 for self-supporting copper and zinc
- BS EN 1991-1-1,3 & 4 for structural loads and be fixed in accordance with the manufacturer's instructions.

Profile sheet roofing can be:

- site assembly - including self-supporting metal liner, outer metal profile, held apart by site installed structural support system, with insulation between liner and profile layer
- factory insulated panels (ie, sandwich or composite panels) - metal inner and outer skins adhesively or cohesively factory bonded to a thermal insulation to form a composite self-supporting assembly.

An air and vapour control layer must be provided on the warm side of the insulation.

**Note**  
Subject to the profile manufacturer's recommendations the AVCL can be formed by sealing the side and end laps of the metal liner or by the provision of a separate AVCL membrane directly above the inner liner. The AVCL must be fully sealed around all penetrations and at the roof perimeter and have a vapour resistance of at least 500 MNs/g. Note: if high density polythene is used it must be reinforced 1000 gauge or more and of virgin material.

Insulation should contact both the inner and outer metal layers. Any voids formed by the profile of the outer sheet metal roof covering should be ventilated. Ventilation can be achieved by leaving open the profile at both ends of the sheeting above the insulation. If profile fillers are fitted, they should leave a free area of not less than 5% of the cross-sectional area of the void. Where the insulation is likely to be affected by local condensation, a breather membrane should be provided on top of the insulation to discharge condensate externally in accordance with the profile manufacturer's recommendations.

The profiled panels should be fixed using suitable fixings which avoid bimetallic corrosion in accordance with the manufacturer's recommendations.

### Twin skin build-up

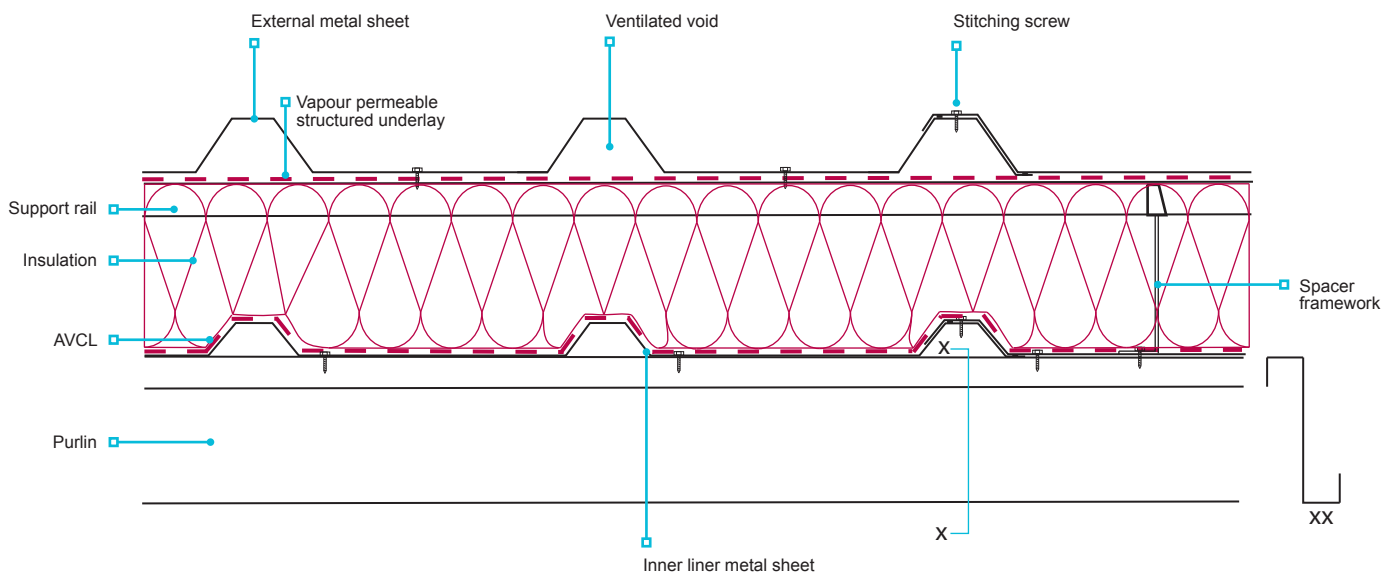

### Standing seam roof (secret fixings)

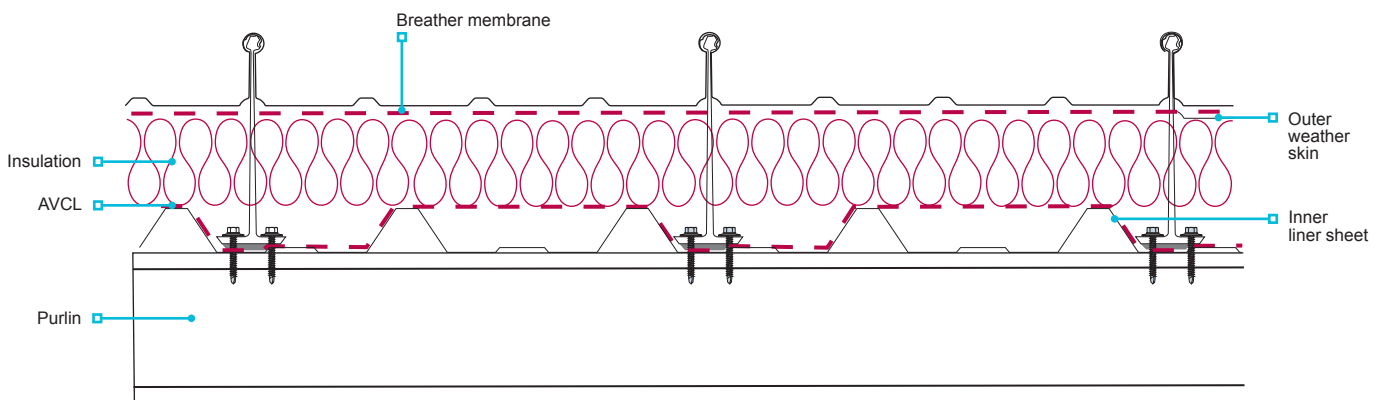

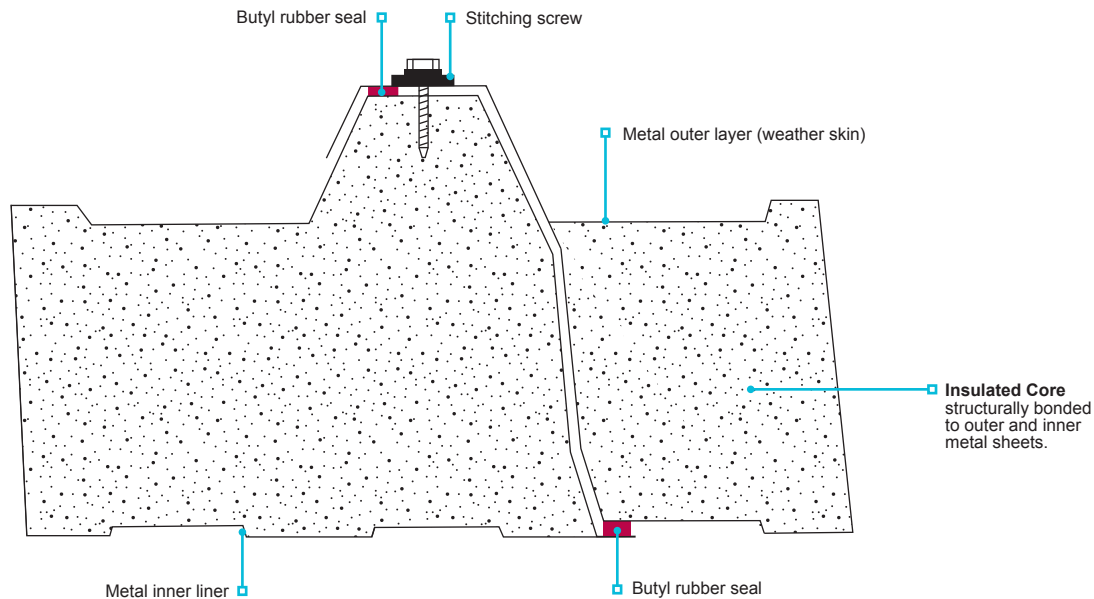
**Example of edge seal with composite roof panels**

The panel side laps, and end laps should be sealed to provide an air barrier as part of the overall air leakage and vapour control requirement of the building, in accordance with the panel manufacturer's instructions.

**7.1.10 Thermal insulation and vapour control**

(See also: BRE Report 'Thermal insulation avoiding risks' and BS 5250)

**Thermal insulation, vapour control and ventilation shall ensure satisfactory performance, and prevent the formation of condensation which could adversely affect the construction. Issues to be considered include:**

- |  |                             |
|--|-----------------------------|
| a) thermal characteristics of roof types | c) control of water vapour. |
| b) types of insulation                   |                             |

**Thermal characteristics of roof types**

**Uninsulated roof** – The temperature of the deck is at or close to that of the interior or exterior of the building whichever is the lesser.

**Cold roof** – The temperature of the deck is at or close to that of the external climate. Cold roof designs should be limited to roofs where it can be shown that effective cross ventilation can be provided to reduce the risk of interstitial condensation

**Warm roof** – The temperature of the deck is at or close to that of the building interior.

**Inverted warm roof** – The temperature of the deck is at or close to that of the building interior. The WFRL should be designed and installed to collect and drain most of the rainwater to reduce water entering and cooling the insulation layer.

Condensation analysis should be calculated using an external temperature of -5C in accordance with BS 6229.

**Types of insulations**

Types of insulations and their use should be in accordance with Table 8.

Table 8:

Insulation material	Abbreviation	BS EN Standard	Applications	
			Warm roof	Inverted warm roof <sup>1</sup>
Expanded polystyrene board	EPS	13163	yes <sup>2</sup>	no <sup>3</sup>
Extruded polystyrene board	XPS	13164	yes <sup>2</sup>	yes
Rigid polyurethane foam board	PUR, or PU,	13165	yes	no
Phenolic foam board	PF	13166	yes	no
Polyisocyanurate board	PIR	13165	yes	no
Cellular glass board	CG	13167	yes	no <sup>3</sup>
Expanded perlite board	EPB	13169	yes	no
Cork board	ICB	13170	yes	no
Fibreboard, bitumen-impregnated (used in conjunction with EPS with hot applied waterproofing)			yes	no
Composite boards or decks (eg Plywood + PIR)			yes	no
Resin bonded mineral wool rigid board	MW	13162	yes	no
Mineral wool quilts <sup>4</sup>	MW	13162	no	no
Vacuum insulation panels <sup>5</sup>	VIP		yes	yes

Notes

- 1 Thermal insulation used in inverted roofs should be designed in accordance with ETAG 031-1
- 2 Suitably protected when using hot applied waterproofing
- 3 Unless the product has an independent third-party assessment for use in inverted warm roofs
- 4 Not suitable for warm or inverted warm roofs and only used in cold roofs
- 5 Suitably assessed in accordance with Technical Requirement R3.

Insulation for warm roofs should be:

- either:
  - bonded or mechanically fixed to resist wind uplift in accordance with the manufacturer’s recommendations; where mechanically fixed, it should be installed using fixings of sufficient length to ensure adequate penetration into the supporting structure, or
  - part of a loose laid roof system which is ballasted to resist wind uplift
- kept dry and installed in quantities which can be quickly covered if it rains (to aid bonding and to avoid trapping moisture)
- dimensionally stable at working temperatures (eg 100°C under metal roofs)
- lightly butted to avoid gaps.

Insulation for inverted roofs should be:

- extruded polystyrene (XPS), or expanded polystyrene (EPS) suitably assessed in accordance with Technical Requirement R3
- suitable for external use
- ballasted to avoid floatation and wind uplift
- suitable for the weight of the ballast and able to withstand anticipated traffic and design loads
- protected by a breathable water flow reducing layer (WFRL) to reduce the cooling effect of cold water flowing into and under the thermal insulation and across the waterproofing layer
- calculated to take account of the cooling effect of rainwater seeping through the insulation board joints in accordance with BS 6229 and ETAG 031-1 and the dry calculated thickness increased to allow for this cooling effect.

Note

A WFRL should be designed and installed to drain most of the water from the roof. It should be installed at right angles to the designed slope of the roof, starting at the bottom of the slope. All side and end laps should be a minimum of 300mm. The WFRL should be star cut around pipes and wrapped with additional piece of membrane, turned up at upstands and penetrations, and turned down at drainage locations/outlets.

Composite insulated timber decks should:

- have two beads of sealant along each board joint at the foil under face (to maintain the integrity of the vapour control layer) in accordance with the board manufacturer’s recommendations.

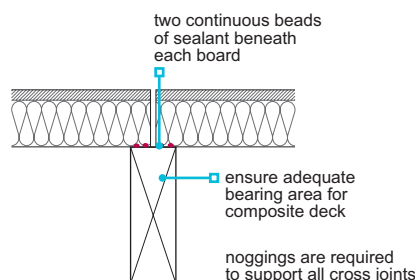

## Control of water vapour

The movement of water vapour within the roof construction must be controlled to avoid the risk of interstitial condensation. This can be achieved by providing an air and vapour control layer (AVCL) on the warm side of the insulation.

In a cold roof the addition of ventilation to the void(s) between the insulation and decking can also assist by removing water vapour from within the construction.

Warm roofs do not incorporate ventilation and rely entirely on the AVCL to avoid interstitial condensation. It is therefore essential that a good quality AVCL is used and that all laps, joins or penetrations are fully sealed. All AVCL's should be fully checked for any damage just prior to being covered over. Any damage should be repaired using a full width section of membrane. Penetrations should be kept to a minimum and fully sealed to the AVCL.

In an inverted warm roof, the waterproofing layer also acts as the AVCL. Control of interstitial condensation also relies on the thermal insulation above the waterproofing layer being kept free from running or ponding water between the insulation and waterproofing layer and within joints between the insulation boards. This should be controlled by the correct installation of the WFRL laid over the insulation.

AVCL's can be formed with one of the materials listed in Table 9.

**Table 9:** Materials for AVCL

Material	Specification
Reinforced bitumen membranes	BS 8747 BS EN 13970
Self-adhesive Polythene/ metal foil/ bitumen membranes for cold self-adhesion	BS EN 13970 BS EN 13984
High density Polyethylene sheet with metal foil core	BS EN 13984
High density Polyethylene sheet	BS EN 13984
Plastic and rubber sheets	BS EN 13984
12mm one coat mastic asphalt on glass fibre tissue	BS 6925

**Note**

Metal-cored flexible reinforced bitumen membranes are also suitable to form an AVCL.

AVCL's to warm roofs should:

- include at least one layer of reinforced bitumen roofing membrane (S2P3) below the insulation, fully or partially bonded to the structural deck as appropriate, or a suitable self-adhesive or torch-on membrane
- be self-sealing (eg self-adhesive aluminium foil-backed modified bitumen membrane) if penetrated by mechanical fixings, (eg those securing the insulation boards to the deck)
- be sealed and lapped to the waterproofing layer (where compatible) at the perimeters and at each penetration, eg at outlets and pipes, rooflights etc or extended up a minimum 50mm above the insulation and sealed to the wall, rooflights etc
- be fixed to resist the calculated wind uplift forces.

AVCL's for warm roof constructions supporting traditional hard metal roofs should have a minimum vapour resistance of 4000MNs/g and be fully supported.

Any fixings that penetrate the AVCL eg those securing insulation boards to the deck, should be carefully installed to avoid creating open perforations that would allow water vapour to pass through.

Cold flat roofs are difficult to detail correctly but, where used, they should be in accordance with BS 6229 and BS 5250 and have:

- an effective air and vapour control layer at ceiling level
- an unobstructed minimum 50mm ventilation space above the insulation
- adequate cross ventilation (openings at both ends of each joist void equivalent to a minimum 25mm gap)
- a maximum clear distance of 5m between ventilators on opposite sides of the roof.

**Note**

All ventilation gaps should have protective mesh or grilles (nominal 4mm openings) to avoid entry of large insects and birds.

### 7.1.11 Waterproofing layer and surface treatments

Flat roofs, and balconies forming roofs, shall adequately resist the passage of water to the inside of the building. Issues to be considered include:

- |  |                       |
|--|-----------------------|
| a) installation of waterproofing layer | c) surface treatments |
| b) waterproofing systems               | d) fire protection.   |

#### Installation of waterproofing layer

Prior to the waterproofing layer being installed:

- the surface should be even and dry and any nails should be punched, or screws countersunk, below the surface
- any penetrations for drainage, services, rooflights etc should be formed before the waterproofing layer is applied
- the manufacturer's recommendations for the preparation, including priming upstands, roof outlets, etc should be followed to achieve a satisfactory bond with the waterproofing layer
- the manufacturer's recommendations for conditioning, and unrolling membranes in advance of laying, should be followed.

Environmental conditions should be suitable for installing the waterproofing layer. Issues to be considered include the following:

- membranes should not be installed or handled when the product temperature and the air temperature is 5°C or less unless otherwise agreed with the manufacturer
- self-adhesive bitumen membranes should not be installed or handled below 5°C, unless otherwise permitted by the manufacturer
- membranes should not be installed on damp or frosted surfaces or when any rain, sleet or snow is falling.

Waterproofing layer should be:

- secured in a manner that resists the wind uplift.
- secured in a manner that allows expansion of metal decks
- installed in accordance with the design and the manufacturer's recommendations
- installed by a specialist roofing contractor approved by the manufacturer, where a proprietary system is used
- installed by the same contractor who installs the air and vapour control layer, insulation and surface finish
- checked by the contractor to ensure that the deck and insulation boards are waterproofed at the end of each day with 'night joints' and before inclement weather
- installed so that membrane laps near outlets do not impeded drainage ie, outlets should be recessed to avoid forming a raised lip with the waterproofing layer
- installed so that successive layers do not trap water.

Inverted roofs should:

- not be used for slopes greater than 10 degrees
- be laid on a deck with no back falls or ponding
- be designed to support the loads, particularly from ballast needed to retain insulation
- be ballasted to the depth specified in the design to resist wind uplift, flotation and provide fire protection, using minimum 40mm paving slabs or 20-40mm diameter rounded shingle ballast minimum 50 mm deep, subject to any other requirements to meet fire protection measures
- installed with a separating layer between the waterproofing layer and inverted warm roof insulation where required by the membrane manufacturer.

Note

The depth of ballast required to resist flotation may exceed the minimum depths needed to meet the fire protection.

**Table 10:** Waterproofing layer materials

Material	Standard	Code of practice	Other guidance
Reinforced bitumen membrane (RBM)	BS 8747 BS EN 13707	BS 8217 BS 6229	
APP & SBS modified bitumen roofing systems	Independent Third-Party Assessment BS EN 13707	BS 8217 BS 6229	
Mastic asphalt	BS 6925	BS8218	MAC Technical Guide
Plastic and rubber sheets	BS EN 13956		SPRA Design Guide
Liquid applied waterproofing (hot or cold applied)			LRWA Design Guide ETAG 005

**Reinforced bitumen membranes and modified bitumen roofing systems**

Bitumen membranes should be high performance to BS EN 13707 'Flexible sheets for waterproofing – reinforced bitumen sheets for roof waterproofing – definition and characteristics' and reinforced with polyester reinforcement. SBS (elastomeric) modified bitumen membranes offer increased extensibility and flexibility, especially at low temperatures, whilst APP (plastomeric) modified bitumen membranes offer resistance to UV degradation and high softening points, and both provide a longer service life than traditional RBMs.

Built-up bitumen membrane roofs should be complete systems provided by the membrane manufacturer and installed in accordance with BS 8217 'Reinforced bitumen membranes for roofing – Code of practice' and the membrane manufacturer's instructions.

The installation methods should consider the safe use and application of any hot applied materials including such guidance as the NFRC's 'Safe to torch'.

**Table 11:** Modified bitumen membranes used in warm roof construction

Deck	Preparation	AVCL RBM Minimum (S2P3) or Modified bitumen membranes	Insulation	First /preparatory layer (S2P3)	Final layer /cap sheet <sup>2</sup> with integral surface protection <sup>3</sup>
Concrete or screed	Smooth surface, and prime	Applied in accordance with the membrane manufacturer's instructions	See Note 1	Applied in accordance with the membrane manufacturer's instructions	Applied in accordance with the membrane manufacturer's instructions
Plywood or OSB	Prime deck				
Profiled metal eg steel, aluminium	Stitch side laps, prime crowns (or timber decking where provided)				

**Table 12:** Modified bitumen membranes used in an inverted warm roof construction

Deck	Preparation	First/preparatory layer (S2P3)	Final layer/cap sheet <sup>2</sup>
Concrete or screed	Smooth surface and prime	Applied in accordance with the membrane manufacturer's instructions	Applied in accordance with the membrane manufacturer's instructions

Notes to Tables 11 and 12

- 1 Insulation to be mechanical or adhesive fixed to deck in accordance with the design of the roof build-up. Torching on to insulation boards and timber deck is not acceptable, apart from suitable insulation boards eg rock fibre, perlite or foam insulation boards with a torch receivable facing.
- 2 Classification by performance should be in accordance with BS 8747 eg a minimum value of S2P3 for ballasted roofs with access for light maintenance only and minimum S5P4 for accessible roofs with paving slabs on supports. S = tensile strength and elongation, P=resistance to puncture both static and dynamic, the higher the number the better the performance.
- 3 The use of stone chippings is not recommended unless required to enhance fire protection. Solar reflective paint, if used, should not be used as the sole protective finish to the membrane.

### Mastic asphalt

Mastic asphalt should be:

- to BS 6925, type 988 T25, 20mm thick on the flat and installed on black sheathing felt
- 3 x 10mm layers on horizontal surfaces and 3 layers with a total thickness of 20mm on vertical surfaces, for upstands to walls on Green roofs.

Polymer modified asphalt should be assessed in accordance with Technical Requirement R3.

### Single-ply membrane

Single-ply membranes, including materials such as, PVC (polyvinyl chloride), Ethylene Propylene Diene Terpolymer (EPDM), and TPO (thermoplastic polyolefin), should be:

- either bonded to the insulation, mechanically fixed to the deck or loose laid, and sealed and ballasted. Fixing methods should be in accordance with the manufacturer's recommendations
- welded at laps using either hot air or a specific solvent with or without taped seams
- designed and installed in accordance with SPRA guide
- assessed in accordance with Technical Requirement R3.

### Liquid applied membranes

Liquid applied, include a variety of cold and hot applied membranes, should be:

- selected and applied in accordance with the Liquid Roofing and Waterproofing Association's guidance notes
- applied in accordance with the manufacturer's recommendations
- assessed in accordance with Technical Requirement R3.

### Fully supported flat sheet hard metal roof

Fully supported flat sheet hard metal roof coverings should be designed and constructed:

- to the material Standards as shown in Table 13 or assessed in accordance with Technical Requirement R3
- in accordance with BS EN 14783 'Fully supported metal sheet and strip roofing, external cladding and internal lining. Product specification and requirements'
- in accordance with the relevant Codes of Practice, the FTMRC 'UK guide to good practice' and the supply manufacturer's recommendations. Including allowance for thermal movement and wind uplift
- to avoid damage from condensation
- with maintenance access only.

**Table 13:** Fully supported flat sheet hard metal roof coverings

Metal type	Material Standard
Aluminium (Al)	BS EN 485-1
Copper (Cu)	BS EN 1172
Galvanised Steel (Gst)	BS EN 10346
Stainless Steel (SS)	BS EN ISO 9445 parts 1-2
Titanium Zinc (Zn)	BS EN 988

Direct contact between dissimilar metal roof coverings and metal fixings can cause corrosion, similarly, rainwater from dissimilar metal roofs should not discharge on to one another. Acid run-offs from timber cladding, contact with fresh cement mortar, and acidic cleaners, can also affect metal roofing particularly Zinc, and in marine environments metal roofing can suffer unsightly salt deposits. Various coatings have been developed to protect against corrosive environments and unsightly deposits. Advice on the above aspects should be sort from the metal roofing manufacturer when considering the roof design.

It is essential that interstitial condensation does not build up on the underside surface of metal roof coverings. This trapped moisture will increase the risk of corrosion developing in key parts of the construction containing metals such as Zinc, Galvanised steel and Aluminium. Prevention of interstitial condensation should be achieved by a ventilated design for either of the 'cold' or 'warm' roof types - with each having a ventilated void beneath the deck supporting the metal covering.

Ventilation needs to be effective in accordance with BS 5250 and BS 6229 with minimum 50mm ventilated void with continuous 25mm edge ventilation gaps and a maximum 5m between ventilation points in the direction of the joists. With verge to verge cross ventilation, and ventilation in the direction of the joists and 5-10m between ventilation points, a ventilation gap of minimum 100mm and continuous edge ventilation gaps of 60mm is recommended. Intermediate mushroom ventilators are ineffective in reducing these ventilation distances.

**Note**

Ventilation gaps should have mesh or grilles (nominal 4mm openings) to stop the entry of large insects and birds.

Ventilation also helps form a protective patina to the underside of aluminium, galvanised steel and zinc. Timber sarking boards with 3-5mm gaps between are the preferred deck option, if plywood is used it should have 3-5mm gaps between boards. The metal should be laid on a structural underlay ie, a breathable underlay with outer layer of bonded polypropylene mesh, which assists air and moisture movement all in accordance with the metal roof manufacturer recommendations.

### Ventilated cold roof design

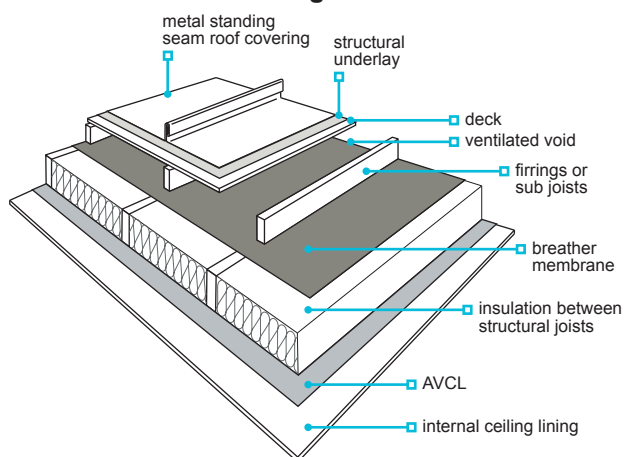

### Ventilated warm roof design

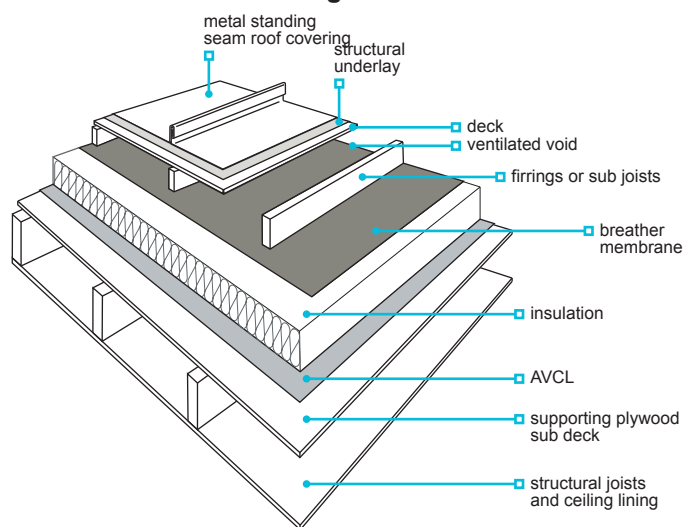

### Fully supported lead roof

Fully supported lead roofing should be:

- laid loose on building paper to BS 1521 Class A for plywood deck or smooth concrete/screed deck, or polyester geotextile felt for timber boards (fitted with penny width air gaps)
- installed as a ventilated cold or ventilated warm roof system
- installed in accordance with BS 6915, The Lead Contractors Association's, 'The ultimate guide to best practice' or manufacturer's recommendations. Including allowance for thermal movement and wind uplift
- designed with maintenance access only
- treated with patination oil directly after installation where rainwater run-off may cause staining to adjoining surfaces.

**Table 14:**

Metal type	Material Standard	Code of Practice
Lead (rolled)	BS EN 12588	BS 6915
Lead (machine cast)	Third-party assessment	

### Integrity testing of waterproofing layer

The waterproofing layer should be inspected for defects after installation. Any defects are to be repaired and retested and left in a satisfactory condition.

Waterproofing layers on flat roofs, terraces and balconies greater than 50m<sup>2</sup>, or roofs which are difficult to access (such as on buildings over 3 storeys), should be subject to visual inspection and an appropriate integrity test, undertaken by a suitably qualified surveyor.

Waterproofing layers under 50m<sup>2</sup> or those unsuitable for electronic testing eg EPDM or foil-faced bitumen membranes, may be checked by visually inspection which should include inspection of any seams with suitable probes.

Guidance on electronic test methods and their application can be found on the 'Roofing And Waterproofing Test Association' website.

A test report containing the test results and photographic record of the roof should be made available to NHBC.

## Surface treatments

Surface treatments should be in accordance with Table 15.

**Table 15:** Surface treatments for flat roofs

Material	Access for maintenance only	Access roof, walkway or terrace
Reinforced bitumen membranes	<ul style="list-style-type: none"> <li>mineral surfaced cap sheets (eg type S5P5)</li> <li>reflective stone chippings<sup>1</sup>, bedded in a bitumen-based compound</li> <li>a minimum thickness of 50mm washed, rounded 20-40mm shingle ballast laid loose</li> </ul>	<ul style="list-style-type: none"> <li>precast semi-porous concrete tiles bedded in bitumen or approved adhesive</li> <li>precast concrete proprietary paving slabs on supports, or sand/cement blinding<sup>2</sup></li> <li>proprietary decking systems<sup>3</sup></li> </ul>
Single-ply membranes	<ul style="list-style-type: none"> <li>supplementary solar reflective coatings or other finishes not required</li> <li>where laid loose, membranes can be ballasted with a 50mm minimum thickness of washed, rounded 20-40mm shingle ballast installed on a non-woven polymeric protection layer</li> </ul>	<ul style="list-style-type: none"> <li>proprietary flexible, non-slip walkway sheets or tiles, compatible with the membrane product</li> <li>precast concrete proprietary paving slabs on adjustable supports or suitable non-woven polymeric protection layer</li> <li>proprietary decking systems with bearers set on an additional membrane or suitable non-woven polymeric protection layer<sup>3</sup></li> </ul>
Cold applied liquid roofing membranes	<ul style="list-style-type: none"> <li>products generally do not require supplementary solar reflective coatings or other finishes</li> </ul>	<ul style="list-style-type: none"> <li>proprietary surface treatments compatible with the membrane product</li> <li>proprietary non-slip walkway tiles compatible with the membrane product</li> <li>precast concrete proprietary paving slabs on supports on a suitable non-woven polymeric protection layer</li> <li>proprietary decking systems with bearers set on additional pads on suitable non-woven polymeric protection layer/filter layer<sup>3</sup></li> </ul>
Hot melt rubberised bitumen systems	<ul style="list-style-type: none"> <li>use in inverted/buried membrane applications or in roof garden/green roofs</li> <li>must be protected with a substantial reinforced bitumen membrane protection sheet or protection board</li> <li>all upstands/details where the membrane becomes exposed need a protective membrane to be applied to prevent UV degradation</li> </ul>	
Mastic asphalt	<ul style="list-style-type: none"> <li>reflective stone chippings<sup>1</sup>, bedded in a bitumen-based compound</li> <li>solar reflective paint in accordance with BS 8218</li> </ul>	<ul style="list-style-type: none"> <li>precast semi-porous concrete tiles bedded in bitumen or approved adhesive</li> <li>precast concrete proprietary paving slabs on supports or sand/cement blinding<sup>2</sup></li> </ul>

### Notes

- Loose surface finishes should be prevented from being removed by weather and discharged into gutters and drainpipes. Chippings should be a minimum of 12.5mm limestone or white spar, not pea gravel.
- Cement/sand blinding should be installed on two layers of 1000 gauge polyethylene separating membrane.
- Decking systems should meet the required fire protection requirements for the overall roof system and should not float in the event of flooding.

## Fire protection

The surface protection provided to the waterproofing layer must satisfy the fire protection requirements as set out in the Building Regulations.

Account must be taken of the waterproofing detail at abutments with a building and the extent that the waterproofing can be dressed up the wall of the building and the jointing detail between the roof waterproofing and the cavity trays/DPC, this may include the use of non-combustible trays, in the external wall of the building.

Extensive green roof systems should include non-combustible perimeter abutment strips to buildings, roof lights etc and at regular intervals across the roof in accordance with the guidance in the GRO fire risk guidance document and Building Regulations.

## 7.1.12 Green and biodiverse (brown roofs) – including roof gardens

Green and biodiverse (brown roofs) shall be suitable for their intended use.

Green and biodiverse roofs should:

- be designed with a finished fall at the waterproofing layer of 1:60 (1°) minimum
- be designed in accordance with the GRO Code of Practice and CIRIA C753 SuDS Manual 2015
- have a certified waterproofing system that is endorsed by the manufacturer as fully suitable to be specified for a Green sustainable roof design
- be designed to take account of wind uplift and flotation
- have supporting data to demonstrate compliance with relevant material standards and codes of practice
- include waterproofing layer suitable for use in the green/biodiverse roof system
- have rainwater outlets that are accessible and have a visible inspection hatch.

Green and biodiverse roof systems that do not comply with the principles of this chapter should be assessed in accordance with Technical Requirement R3.

Both the green/biodiverse roof system and the waterproofing layer should be installed by a contractor trained and approved by the system supplier.

Waterproofing layer should be either:

- reinforced bitumen membrane
- mastic asphalt
- single-ply membrane, or
- a liquid applied system, (cold or hot melt).

The system should be installed in accordance with the design and the waterproofing layer manufacturer's recommendations and integrity tested prior to covering (see integrity testing).

Other issues that should be considered when installing green roofs include the:

- provision of a root barrier or use a waterproofing layer that is resistant to root penetration in accordance with BS EN 13948
- height of upstands in relation to soil height and flashings
- protection, reservoir and filter layers
- moisture control of the soil.

## Intensive green roof on warm roof deck

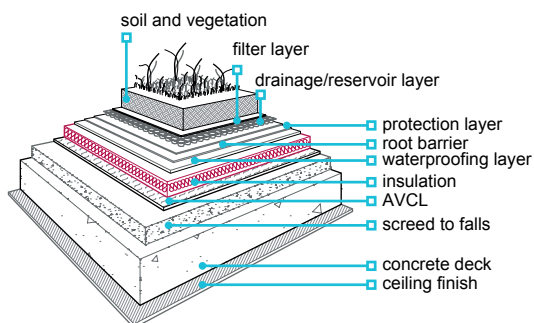

## Extensive green roof on warm roof deck

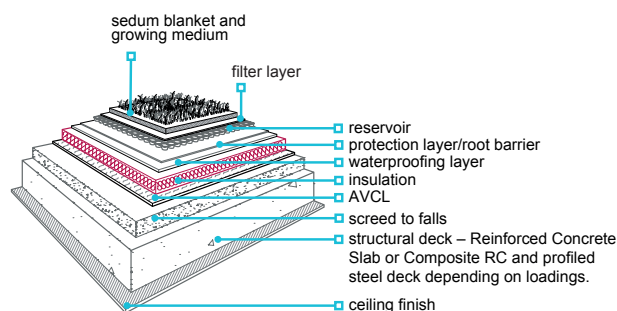

## Intensive green roof on inverted warm roof deck

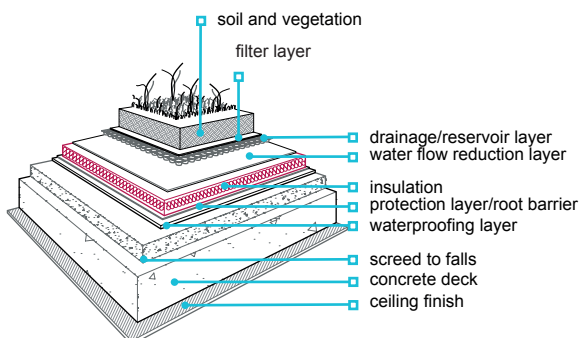

## Extensive green roof on inverted warm roof deck

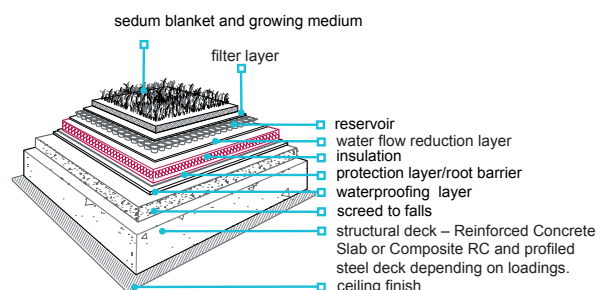

**Table 16:** Principles for green roofs

	Intensive	Extensive
Features	<ul style="list-style-type: none"> <li>provides a normal garden environment</li> <li>uses natural topsoil at least 150mm deep and 'normal' plants such as grass, bushes, shrubs and trees</li> <li>requires regular 'intensive' maintenance ie, like a normal garde</li> <li>requires protection of the waterproofing membrane from possible damage during maintenance of the garden, eg from weeding/planting</li> </ul>	<ul style="list-style-type: none"> <li>requires minimal maintenance, ie, annual attention</li> <li>types of planting includes sedum in a blanket or modular trays, wildflower blanket, non-blanket solutions using plug plants or hydroseeding</li> </ul>
Structure	<ul style="list-style-type: none"> <li>10° maximum roof pitch unless anti-shear measures are taken, accounting for full weight of wet soil (generally supported by a concrete deck)</li> </ul>	<ul style="list-style-type: none"> <li>45° maximum roof pitch deck (profiled metal deck or concrete deck depending on load)</li> </ul>
Drainage Falls	<ul style="list-style-type: none"> <li>finished fall of 1:60 at drainage level</li> </ul>	
Moisture control	<ul style="list-style-type: none"> <li>irrigation system may be required</li> <li>can be designed to retain some water in order to maintain the vegetation and to reduce run off</li> </ul>	
Air and vapour control layer	<ul style="list-style-type: none"> <li>fully bonded polyester - reinforced RBM (S2P3), a suitable self-adhesive membrane, or a torch-on membrane</li> </ul>	
Insulation	<ul style="list-style-type: none"> <li>insulation material should have adequate compressive strength to withstand likely applied loads</li> </ul>	
Roots	<ul style="list-style-type: none"> <li>a root resistant element is required above the waterproofing layer. Alternatively, an approved root resistant waterproofing layer can be used. Note: consideration should be given to the potential for large roots to enter and disrupt inverted warm roof insulation, the system provider should be consulted for advice</li> </ul>	
Protection and filter layers	<ul style="list-style-type: none"> <li>a protection layer (or board) should be placed above the waterproofing layer</li> <li>a filter layer should be placed above the reservoir layer</li> </ul>	<ul style="list-style-type: none"> <li>in accordance with the manufacturer's recommendations</li> </ul>

### 7.1.13 Blue roofs

**Blue roofs shall be suitable for their intended use.**

Blue roofs should:

- be designed in accordance with relevant parts of BS 6229: 2018 and the NFRC Technical Guidance Note for Construction and Design of Blue Roofs. Roofs and podiums with controlled temporary water attenuation
- have a certified waterproofing system that is endorsed by the manufacturer as fully suitable to be specified for a Blue sustainable roof design
- have supporting data to demonstrate compliance with relevant material standards and codes of practice
- include waterproofing layer suitable for use in the blue roof system and subject to independent third-party assessment
- have specific flow restrictor outlets to meet the required water discharge rate and which are accessible for inspection and maintenance
- fully drain over the designed retention period. Permanent retention of water is not accepted on the roof waterproofing layer
- include overflows independent of the rainwater drainage system, to avoid water ingress into the building should the water attenuation level be exceeded. Operation of an overflow should be visible to warn of a potential blockage in the drainage system
- have minimal penetrations of the waterproofing layer other than rainwater outlets and overflows
- be designed as a warm roof or inverted warm roof.

If designed as an inverted warm roof the design should take into account the additional thickness of insulation, over and above the dry state 'U' value calculation, that is required to compensate for the cooling effect of water penetrating the insulation and reaching the waterproofing layer, in accordance with the guidance in BS 6229.

The design should also include sufficient topping of ballast, paving or green roof to avoid flotation of the insulation, Flotation forces can be quite significant and occur before the attenuation system reaches full capacity.

Care should also be taken in the design and installation of the WFRL so that it performs as the principal drainage layer and reduces water penetration to the insulation layer below.

The WFRL should be:

- lapped and sealed to avoid/minimise rainwater getting below the insulation layer
- lapped and taped onto the lip of the water attenuation chamber
- finish a minimum of 50mm above the top of the blue roof attenuation level at parapets/upstands
- taken up all protrusions/penetrations and sealed. This includes between the top of the insulation layer and the bottom of the recessed lip of the water attenuation chamber, and behind parapet chambers.

### 7.1.14 Raised and buried podiums

**Podiums shall be protected by adequate weatherproofing and drainage.**

#### Podium roofs

Podiums shall be protected by a fully co-ordinated waterproofing and drainage system as part of the design. Products used for waterproofing and damp proof courses should have accredited 3rd Party Certification with proof of performance from relevant testing. For particular specified conditions of use in construction, wherever applicable, this testing should include membrane resistance to root penetration and durability performance for waterproofing of concrete surfaces trafficable by vehicles. Also, where relevant for compliance, refer to NHBC Standards Chapter 5.4, BS EN 13967: 2012 and PCA Guidance document - Podium Decks and Buried Roofs.

A raised podium is a deck or terrace, usually situated over a non-habitable space where thermal insulation is generally not required.

Waterproofing system combinations should be designed and installed to fully protect the envelope and provide continuity of a water-resistant barrier, along all interfaces between the raised podium ie, bridging across to the superstructure and/or the basement substructure. NHBC Standards chapter 5.4 provides further details for the design and construction of podiums at or below ground level (buried podiums).

The make-up of the waterproofing layer and topping should follow the guidance given for the individual waterproofing layers and toppings quoted within this chapter and to suit the type of deck that has been used to form the podium.

Consideration must be given to emergency vehicular traffic at the planning stage and, where necessary, waterproofing and structural designs must be capable of accommodating foreseeable loading.

#### Raised podium

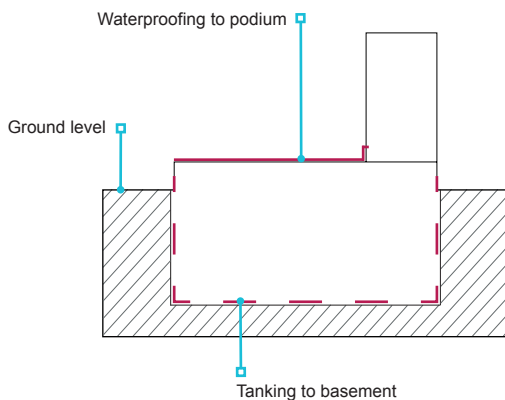

#### Buried podium

See Chapter 5.4 'Waterproofing of basements and other below ground structures'.

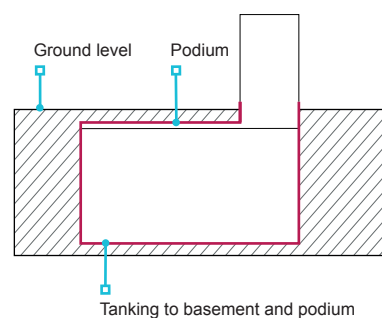

### 7.1.15 Detailing of flat roofs

Flat roofs shall be detailed to ensure satisfactory performance.

**Table 17:** Flashings materials

Flashing material	Guidance
Rolled lead sheet	Minimum code 4. BS EN 12588
Aluminium and aluminium alloys	BS EN 485 and BS EN 573, 0.6-0.9mm thick and protected from contact with mortar by a coating of bituminous paint.
Zinc alloys	BS EN 988 and 0.7mm thick.
Copper	BS EN 1172, 0.6mm thick and fully annealed.
Stainless steel	BS EN ISO 9445 parts 1-2
Galvanised steel	BS EN 10142/3
Proprietary flashing, including plastic and composite.	Assessed in accordance with Technical Requirement R3.

**Note**  
Where two metals are to be joined, they should be compatible and not cause bimetallic corrosion in that environment. Alternatively, they should be isolated from each other.

The following illustrations are intended as a guide to demonstrate the general principles of the flat roof detailing commonly used on flat roofs, terraces and balconies. Where indicated, the principles are applicable to other types of roof construction. Further information on specific waterproofing systems may be obtained from BS 6229 and BS 8217.

#### Concrete Decks

##### Upstands

Upstands may be fixed to the wall.  
Upstands should be a minimum of 150mm high.  
Similar details apply to inverted roofs with concrete decks.

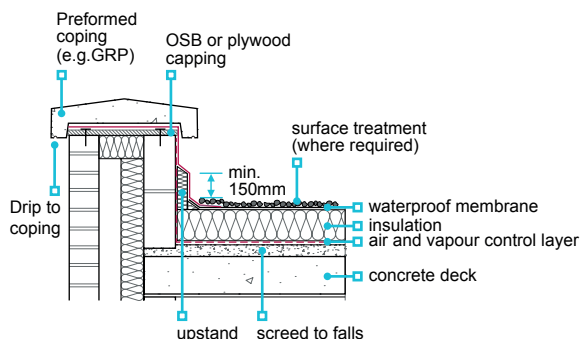

##### Skirting to rooflights or ventilator kerb

Similar details apply to inverted roofs.  
Allow for thickness of ballast to achieve a minimum 150mm upstand.

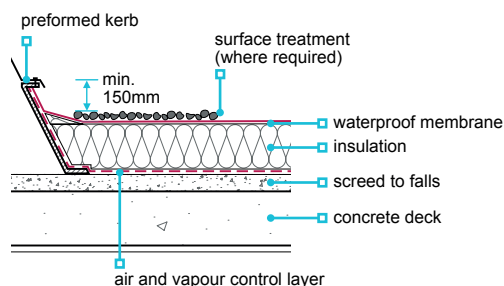

##### Twin-kerb expansion joint

Similar details apply to inverted roofs.

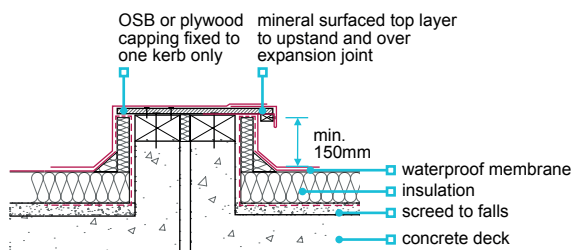

**Timber decks****Mansard edge**

Elements should be firmly fixed to prevent peelback in high winds.

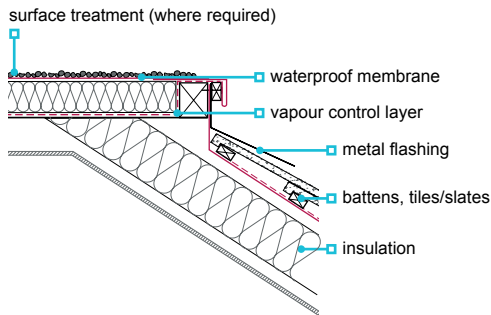
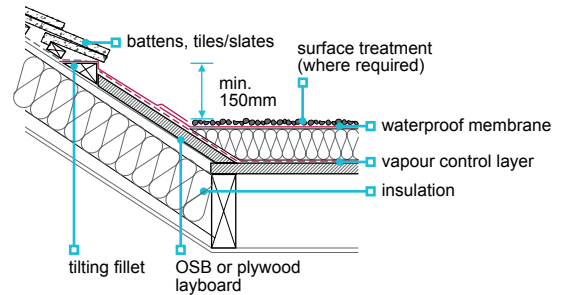
**Pitched roof abutment****Independent skirting detail**

Upstand should be kept separate from wall, and allow for movement. Upstand should be a minimum of 150mm high above surface finish. Similar details apply to cold deck timber roofs.

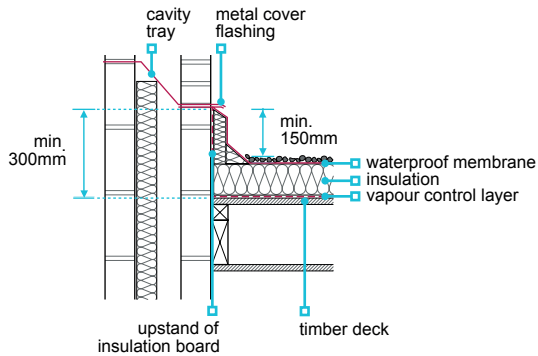
**Verge detail**

Similar details apply to inverted decks.

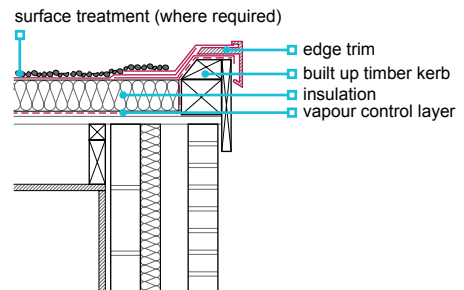
**Welded drip to external gutter**

Inverted timber decks should be detailed to avoid insulation being lifted by wind suction and an alternative detail used.

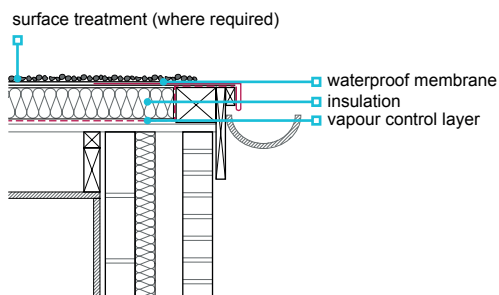
**Pipe passing through roof**

Vapour control layer should be bonded to the waterproofing. Detailing of upstand and flashing is similar for all roofs.

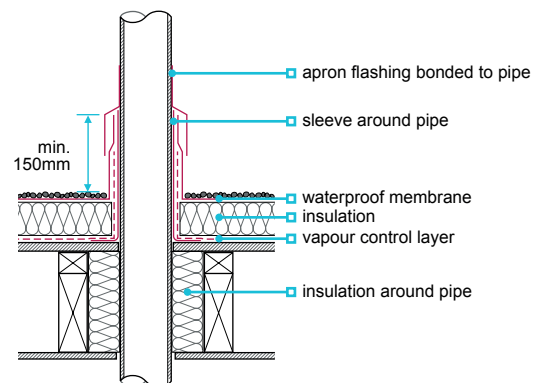

### Upstand to ventilator or rooflight kerb

Similar details apply to cold and inverted roofs. Allow for the thickness of ballast in inverted roofs, to achieve upstand dimensions.

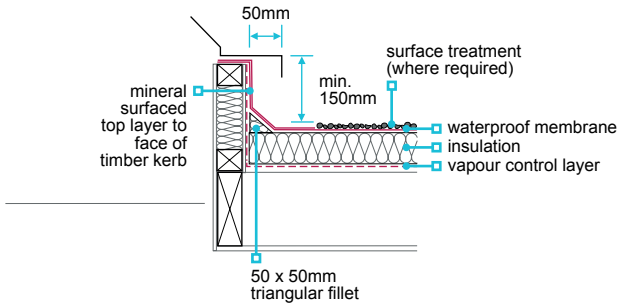

### Rainwater outlet

The opening should be properly trimmed.  
The outlet should be at the lowest point in roof.  
Ensure that the outlet is fixed securely to decking to prevent displacement by thermal expansion of rainwater pipe.  
Similar details apply to concrete roofs.

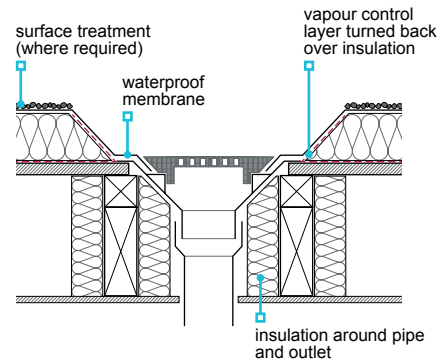

### Inverted warm roof drainage outlet

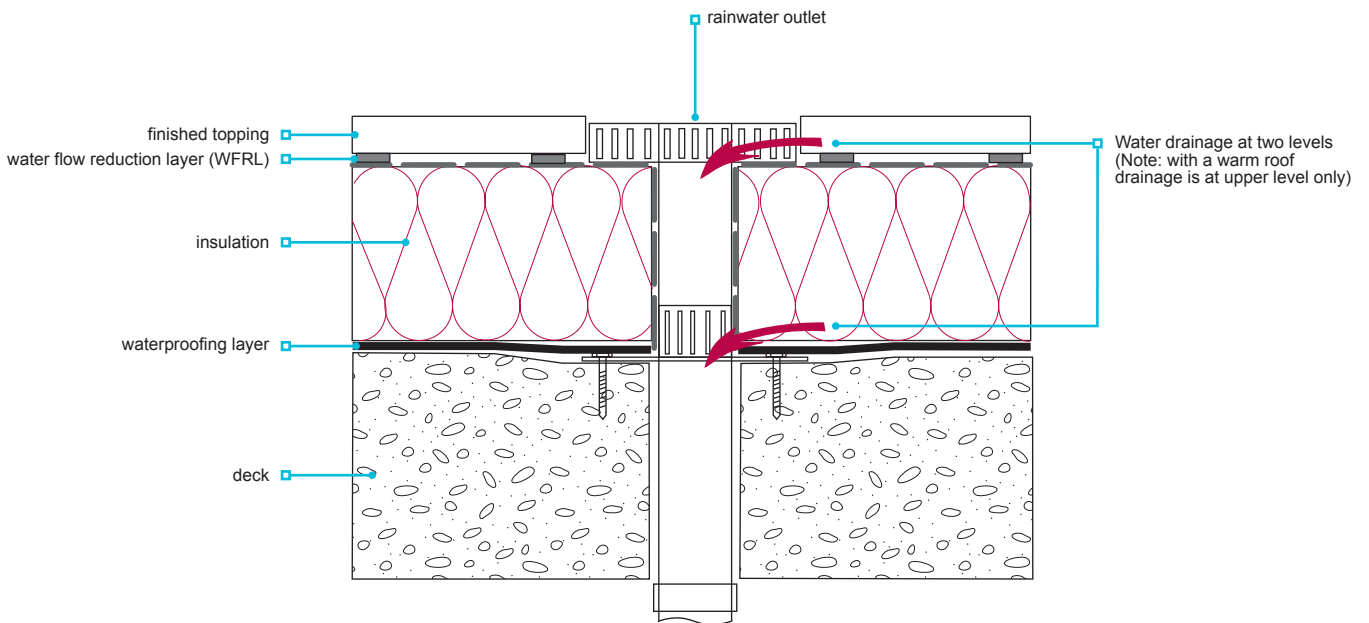

**7.1.16 Accessible thresholds and upstands****Accessible thresholds shall be protected by adequate weatherproofing and drainage.**

Generally, where a flat roof or terrace abuts a wall the waterproofing layer should extend up the wall to form a minimum 150mm upstand measured from the balcony/terrace drainage layer of the roof/terrace. The waterproofing material forming an upstand should link directly under a cavity tray to ensure the cavity fully drains. Weepholes should be provided in masonry walls at 1m maximum spacings to assist drainage.

Where there is a door threshold or a window sill less than 150mm above the balcony/terrace drainage layer and there is a requirement for level access, or the fenestration design involves windows at or close to internal floor level and the paving/decking level, then the following upstand and accessible threshold design requirements, as shown in the diagrams below, should apply.

Designs which continue the waterproofing layer horizontally through/under the outer leaf of a cavity wall and form an upstand against the inner leaf within the cavity are not acceptable because:

- materials used for the waterproofing layer are generally unsuitable to perform as a DPC supporting masonry loads
- the cavity must fully drain to avoid water retention and associated problems through prolonged saturation of the wall material, frost action and water turning stagnant
- water draining from the waterproofing layer must not be directed into a cavity wall
- future inspection, repair and maintenance of hidden upstands cannot be carried out without significant disruption to the construction.

Accessible thresholds should:

- be in accordance with the design - specific fire, thermal and acoustic precautions may be required
- have a maximum 15mm upstand at the threshold (measured at the door position); additional sloping transition elements, such as a small internal ramp and external sill, may be provided either side of the upstand; the maximum slope on the ramps and sills should be 15 degrees
- have a minimum 45mm projecting sill to shed rainwater away from the interface with the waterproofing layer with a drip feature a minimum 30mm away from the face of the upstand
- have a 75mm minimum balcony upstand below the underside of the projecting sill, measured from the balcony/terrace drainage layer.

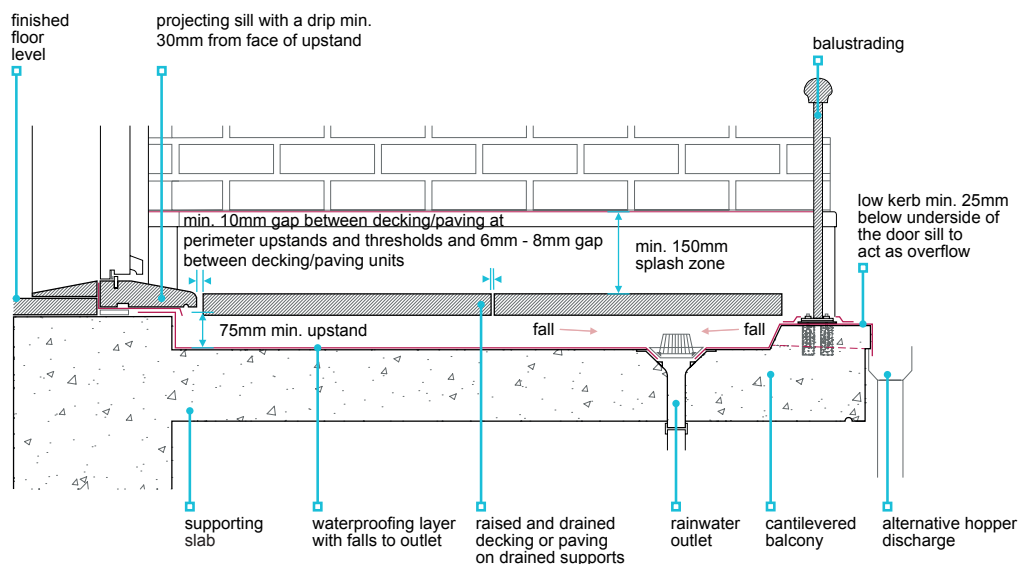
**Uninsulated balcony deck**

**Insulated terrace deck**

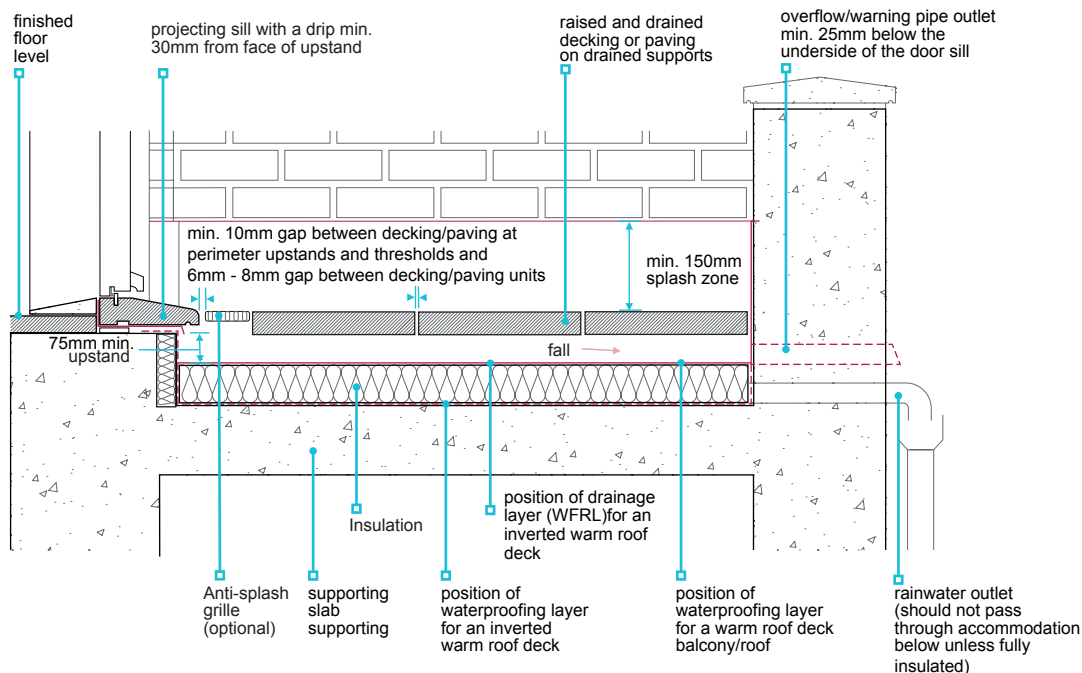

**Accessible threshold**

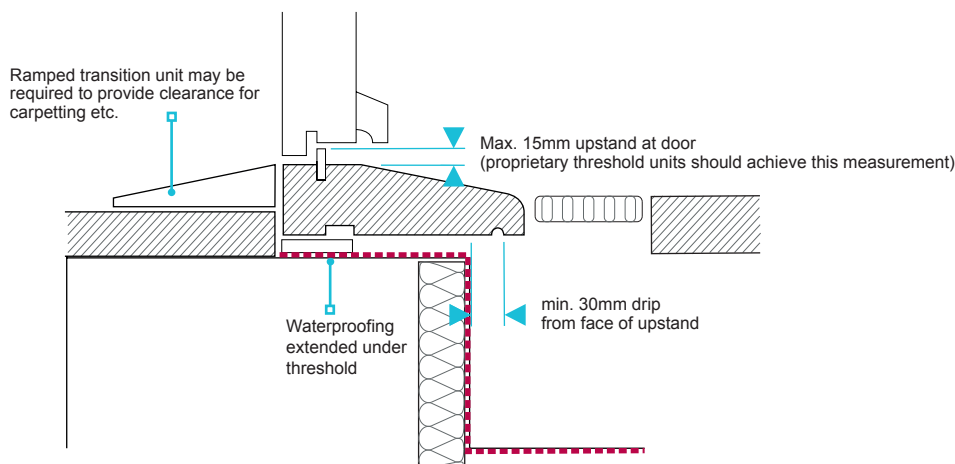

Waterproofing layers should:

- be laid without forming ponding and associated stagnant water
- have a finished fall of a minimum of 1:80 to rainwater outlet(s)
- be subject to specific third-party assessment where falls are zero degrees with no back falls or ponding
- be designed to ensure that where falls are towards or parallel to the building, blockage of the outlet(s) cannot cause flooding to the building
- be fully protected from direct trafficking
- be capable of withstanding point loads from supports to decking or paving
- be UV resistant or fully protected from daylight.

Drainage arrangements should be effective and have a suitable overflow. The building should not flood where an outlet or downpipe is blocked. This can be achieved by using:

- at least one outlet and an overflow with at least the capacity of the outlet
- at least one outlet chute and hopper (chute should be sized to serve at least twice the discharge capacities to allow for partial blockage without causing flooding into the building)
- two outlets connected to independent downpipes such that if one downpipe becomes blocked the other outlet(s) can still cope with the discharge, or
- setting the balcony kerb a minimum 25mm below the door threshold to discharge safely without causing any adverse effect to the construction below.

Outlets beneath decking or paving should be clearly identified and accessible for maintenance.

To ensure adequate drainage:

- As-built gaps of 10mm - 12mm should be provided between decking/paving units along perimeter upstands/thresholds
- As-built gaps of 6mm - 8mm should be provided between individual units of decking or paving
- spacers and supports which raise the decking or paving should not obstruct the flow of rainwater to outlet(s).

A splash barrier around the perimeters should be provided:

- to ensure water does not reach any part of the wall that could be adversely affected by the presence of moisture
- to a minimum of 150mm above the decking or paving
- using an impervious wall finish or cladding or by extending the waterproofing layer to form an upstand with cover flashing and cavity tray. Note: impervious masonry units with porous bed joints are unsuitable within this zone.

### 7.1.17 Metal balcony decking systems

**Metal balcony framework structures and metal balcony decking systems should be designed and constructed as recommended in BS 8579 guidance for the design of balconies and terraces and their component parts.**

### 7.1.18 Parapets and guarding to terraces and balconies

**Terraces and balconies to which persons have regular access other than for maintenance, shall be adequately guarded to minimise the risk of falling. Issues to be considered include:**

- |  |  |
|--|--|
| a) guarding  | d) durability and fixing of balustrading and guard rails |
| b) stability of guarding   | e) access for maintenance.                               |
| c) strength, movement and weatherproofing of masonry balcony walls |  |

#### Guarding

Guarding should:

- not be easily climbed by young children
- be to an adequate height
- be toughened glass, laminated glass (subject to meeting fire regulations) or glass blocks (suitably reinforced) where glazed balustrading is used
- not inhibit the flow of drainage on the waterproofing layers or overflows in the event of a blocked outlet.

#### Stability of guarding

Guarding, including parapet walls and balustrading used as guarding, should be designed in accordance with BS EN 1991-1-1 to resist horizontal loading and as required by Building Regulations. Care is needed when the design incorporates balustrading fixed to parapet walls to ensure stability and prevent overturning. End fixings into walls or returns may be needed to ensure stability.

In balcony walls (especially long balconies) the structural stability should be checked, as cavity trays and DPCs in the wall can create a slip plane that can seriously limit the ability of the wall to resist horizontal forces. In such cases, it may be necessary to incorporate a ring beam or other support to ensure stability.

### Strength, movement and weatherproofing of masonry balcony walls

Masonry balcony walls should be built in accordance with Chapter 6.1 'External masonry walls. In particular:

- walls should incorporate strengthening as required by the design
- movement joints should be provided in accordance with the design
- top of the walls should be weatherproofed with a coping, or by the deck waterproofing layer taken up and over the masonry wall
- copings should be firmly fixed
- copings should project a minimum 45mm beyond the faces of the wall below and incorporate a drip feature that discharges water at least 30mm away from the face of the wall and stops water running back under the coping. Note: preformed edge trims that are sealed to and form a finished edge to the waterproofing layer and which extend down over the wall/fascia, may have a lesser drip projection provided the waterproofing layer drains away from the trim
- copings should incorporate DPCs and cavity trays linked to the waterproofing layer upstands. Cavity trays should be installed to discharge towards the external face of the wall and incorporate weepholes at maximum 1000mm centres.

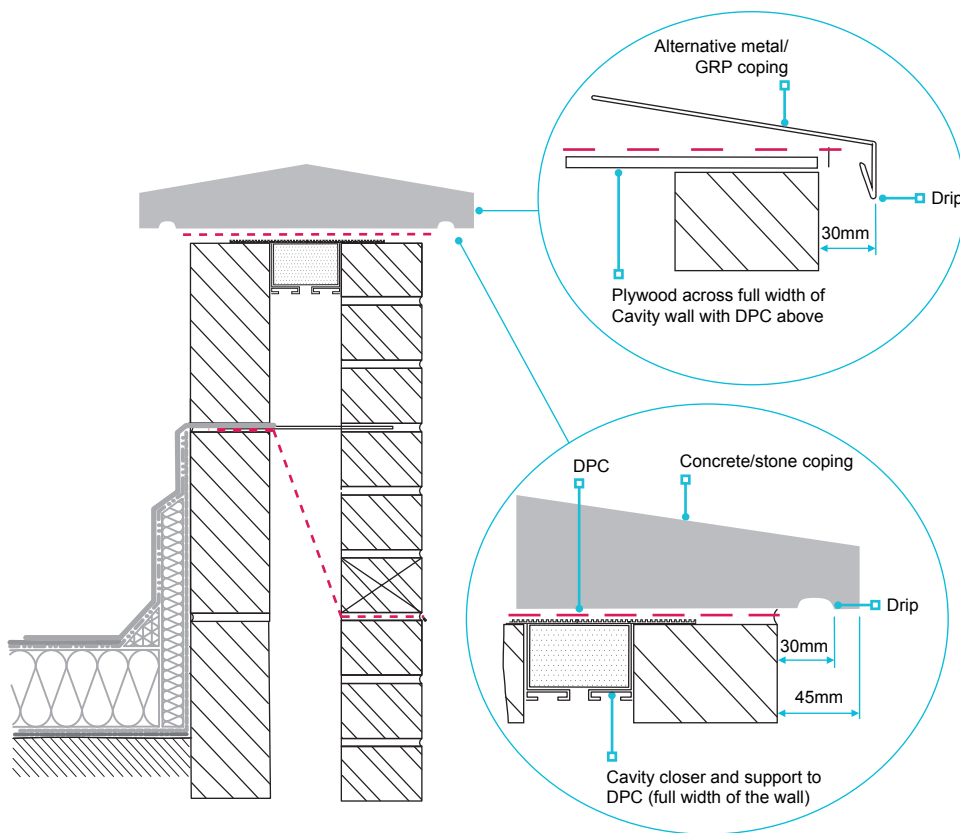

### Parapet detail with waterproofing taken over top of wall and finished with an edge trim

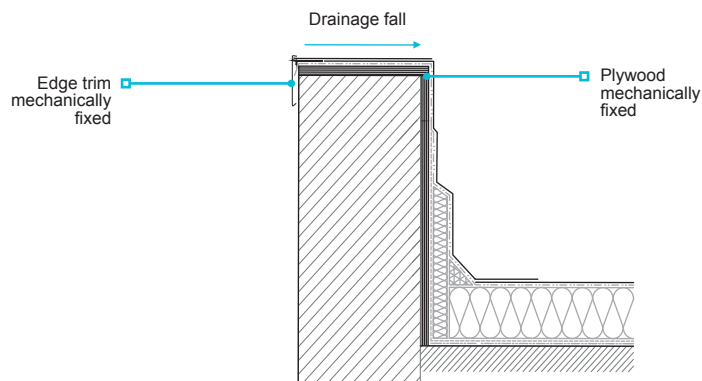

### Durability and fixing of balustrading and guard rails

Balustrading and guard rails should be of adequate durability and fixed securely. The structure to which the balustrading and guard rails are fixed should be adequate to safely resist the potential forces acting on the guarding.

Balustrading should not be:

- fixed through a coping or capping due to the difficulties in achieving a waterproof junction with the coping or capping and maintaining an impermeate DPC beneath the coping or capping. These issues should be avoided by fixing the balustrading to the face of the wall below the coping or capping
- fixed through the waterproofing layer unless suitable precautions are taken to provide a waterproof junction eg locating baseplates on a raised waterproofed kerb or surrounded the baseplates in a pitch pocket detail.

#### Pitch pocket sealing detail around post fixed to deck

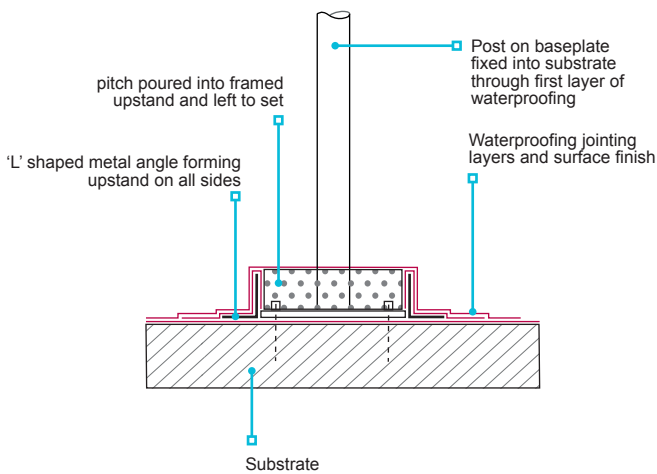

#### Handrail fixing on an upstand formed in concrete roofs

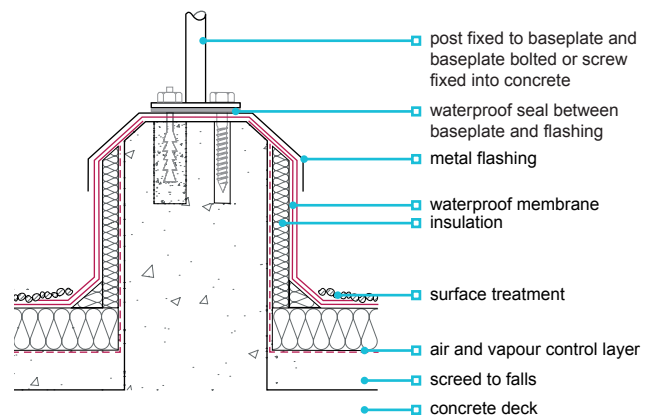

#### Base of balustrade post raised above drainage level

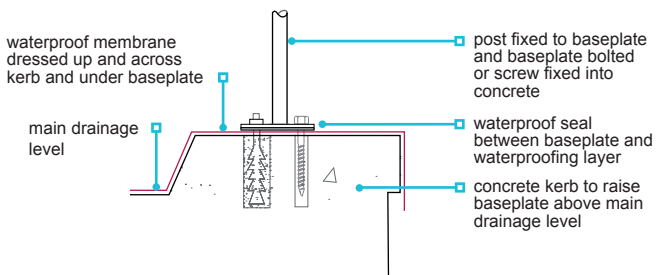

#### Balustrade post fixed to wall below coping/kerb

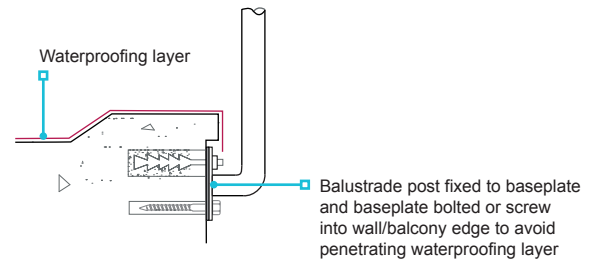

Particular attention should be given to use of materials or finishes that resist corrosion or unsightly surface staining in aggressive environments such as coastal zones.

Note

Ferritic stainless steel can suffer surface rusting/staining in coastal zones.

### Access for maintenance

Provision should be made for safe future access to flat roofs for the purposes of maintenance.

# Chapter 7.2



## Pitched roofs

This chapter gives guidance on meeting the Technical Requirements for pitched roofs, including:

- coverings
- vertical tiling
- fixings
- ventilation
- weatherproofing.

7.2.1	Compliance	01
7.2.2	Provision of information	02
7.2.3	Design of pitched roofs	02
7.2.4	Protection of trusses	05
7.2.5	Durability	05
7.2.6	Wall plates	06
7.2.7	Joints and connections	07
7.2.8	Restraint	08
7.2.9	Bracing for trussed rafter roofs	09
7.2.10	Strutting for site formed attic trusses and cut roofs that form a floor	15
7.2.11	Support for equipment	15
7.2.12	Access	15
7.2.13	Dormer construction	16
7.2.14	Underlay, sarking boards and sheets	18
7.2.15	Ventilation, vapour control and insulation	19
7.2.16	Fire-stopping and cavity barriers	28
7.2.17	Battens	29
7.2.18	Roof coverings	30
7.2.19	Fixing tiles and slates	31
7.2.20	Weathering details	35
7.2.21	Valleys and hidden gutters	39
7.2.22	Drainage	40
7.2.23	Fascias and trim	40
7.2.24	Spandrel panels in cold roofs	41
7.2.25	Roof cassette systems	41
7.2.26	Solar roof panels	42

For figure reference tables in this chapter, please go to the end of the chapter

### Definitions for this chapter

For the purposes of this chapter, the following definitions apply:

<b>Air impermeable weatherproof covering</b>	A roof covering where the airflow through it is not greater than $17.4 A_r$ (in $m^3/h$ )
<b>Air permeable weatherproof covering</b>	A roof covering where the airflow through it is greater than $17.4 A_r$ (in $m^3/h$ )
<b>Air and vapour control layer</b>	A continuous layer to restrict the movement of air and water vapour
<b>Cavity barrier</b>	Cavity barriers are a construction within a cavity, other than a smoke curtain, to either close a cavity to stop smoke or flame entering, or restrict the movement of smoke or flame within a cavity
<b>Coastal locations</b>	A site within a distance of 500m from the general coastline of the United Kingdom
<b>Cold pitched roof</b>	A roof where the insulation is laid horizontally at ceiling level and the space above is unconditioned
<b>Complex roof</b>	Large span roofs of over 12m, or roofs with complex geometry and/or features
<b>Conditioned space</b>	Occupied space in which the temperature and humidity are controlled
<b>Fire-stopping</b>	Fire-stopping is a seal provided to close an imperfection of fit or design tolerance between elements or components, to restrict the spread of fire and smoke
<b>Hybrid roof</b>	A roof where the insulation is positioned partly on a horizontal ceiling, vertical members and partly at the rafter line
<b>Normal ceiling</b>	A ceiling with a typical air permeability of $300 \text{ mm}^2/\text{m}^2$ (0.3%)
<b>Perimeter roofing element</b>	The single roofing element (eg tile, slate, shingle) at any discontinuity in the plane of the roof, including, roof windows, dormers, valleys, roof edges etc
<b>Pitched roof</b>	Part of the external envelope of a building that is at an angle between $10^\circ$ and $70^\circ$
<b>Sarking board</b>	Softwood timber boards, fixed over the rafters of a pitched roof, used for the purposes of roof bracing. Boards may be tongue and grooved or open jointed
<b>Sarking sheet</b>	Tightly jointed sheet boards, fixed over the rafters of a pitched roof, used for the purposes of roof bracing (eg OSB, exterior grade plywood, etc.)
<b>Solar roof panel</b>	Solar roof panels could be either solar photovoltaic or thermal roof panels, and either be 'on-roof' type or integrated into the roof covering
<b>Type HR underlay</b>	A membrane with a high water vapour resistance, $s_d$ , greater than 0.05 m (0.25 MN·s/g)
<b>Type LR underlay</b>	A membrane with a low water vapour resistance, $s_d$ , not exceeding 0.05 m (0.25 MN·s/g)
<b>Unconditioned space</b>	Unoccupied space in which the temperature and humidity are not controlled
<b>Warm pitched roof</b>	A roof where the insulation follows the rafter line
<b>Well-sealed ceiling</b>	A ceiling with a typical air permeability of not more than $30 \text{ mm}^2/\text{m}^2$ ( $\leq 0.03\%$ )

### 7.2.1 Compliance

Also see: Chapter 2.1

#### **Pitched roof structures and coverings shall comply with the Technical Requirements.**

Pitched roofs that comply with the guidance in this chapter will generally be acceptable.

Roofs with a tile or slate covering should be in accordance with BS 5534.

## 7.2.2 Provision of information

**Designs and specifications shall be produced in a clearly understandable format, include all relevant information and be distributed to the appropriate personnel.**

Designs and specifications for traditional cut roofs and roof trusses should be issued to site supervisors, relevant specialist subcontractors and suppliers, and include the following information:

- the layout of cut roofs, trusses and associated items
- details of mono-pitch, lean-to roofs and roof intersections (ie, hips and valleys)
- details of girder trusses, multiple trusses and diminishing trusses, including how they are to be fixed together and supported on truss shoes, layboards or similar
- details of bracing requirements
- details of supports for equipment in the roof space
- the type and position of air and vapour control layers
- details of restraint/holding-down strapping, including coatings and fixings
- the types, position and thickness of insulation
- the means of providing ventilation
- details of fire-stopping at separating wall and boxed eaves
- details of coverings and fixings, including number and type
- details of flashing details at abutments, chimneys, etc
- details of trimming around chimneys, access hatches, etc
- details of loose rafter and floor joist trimming arrangements around staircases, dormer roofs etc where attic trusses are utilised.

For trusses, the design should be provided to the manufacturer in accordance with PD 6693-1, which includes:

- usage, height and location of building, referencing any unusual wind conditions
- rafter profile, referencing camber where required
- spacing, span and pitches
- method of support and position of supports
- type and weight of coverings, including sarking, insulation and ceiling materials
- eaves overhang and other eaves details
- size and approximate position of water tanks or other equipment to be supported
- positions and dimensions of hatches, chimneys and other openings
- type of preservative treatment, where required
- special timber sizes, where required to match existing construction.

## 7.2.3 Design of pitched roofs

*Also see: BM TRADA Eurocode 5 span tables (4th edition) and BS 8103-3*

**The sizing and spacing of members shall ensure structural stability and provide restraint to the structure without undue movement or distortion. Issues to be taken into account include:**

### a) trussed rafter roofs

The design of pitched roofs should:

- have dead, imposed and wind loads calculated in accordance with BS EN 1991-1-1, BS EN 1991-1-3 and BS EN 1991-1-4
- be in accordance with PD 6693-1, and Technical Requirement R5, where appropriate
- be appropriate for the location, accounting for exposure and wind uplift
- ensure that the structure is coherent and that all forces are resolved
- ensure the deflection of floors formed by the bottom chords of attic trusses are in accordance with the requirements of Clause 6.4.9 'Timber joists'

Roofs should be designed by an engineer in accordance with Technical Requirement R5 where:

- the roof is not a basic pitched roof
- hips, valleys or other special features are included in a trussed rafter roof
- the spans, sizes, spacing or strength classes of the timber are outside the scope of authoritative tables

### b) traditional cut roofs.

- ensure that where raised collar trusses are used, as part of the room-in-roof construction, the horizontal deflection of the trusses at the supports should be no more than +/- 6mm
- ensure stability with the complete structure, including the connections and compatibility with the supporting structure and adjacent elements
- where trussed rafters and a cut roof are combined, the designer should provide details of the complete roof (particular care is needed in such circumstances).

- trussed rafters support traditional cut roof members, or
- it is a proprietary system (designs supplied by manufacturers will generally be acceptable).

Structural timber components should be of a suitable strength class as specified by the designer to BS EN 338. Solid structural timber should be:

- machine graded to BS EN 14081, or visually graded to BS 4978 for softwoods or BS 5756 for hardwoods
- assigned a strength class based on BS EN 1912 when visually graded
- dry graded
- marked in accordance with BS EN 14081.

Further guidance on strength classes for certain timber species can be found in PD 6693-1.

Engineered wood products such as I-section or metal-web studs, joists and rafters should be assessed in accordance with Technical Requirement R3.

### Trussed rafter roofs

Trussed rafters should be:

- installed in accordance with the design, and the structure or spacing should not be altered without prior consent from the designer
- fixed to the wall in accordance with the design (eg using double skew nailing or truss clips)
- vertical and suitably located (where necessary, temporary bracing should be used to maintain spacing and to keep trusses vertical)
- evenly spaced at maximum 600mm centres.

Where the maximum 600mm spacing cannot be achieved, eg to accommodate hatch openings or chimneys, spacing may be increased to a maximum of twice the nominal spacing, provided that the spacing  $X$  is less than, or equal to,  $2A-B$  where:

- $X$  = distance between centres of trussed trimmed rafters and the adjacent trussed rafter
- $A$  = design spacing of trussed rafters
- $B$  = nominal width of opening.

Where multiple and reinforcing timbers to simple or multiple trussed rafters are used, they should be:

- designed to be permanently fastened together
- either fixed together during manufacture, or fully detailed drawings and specifications showing the fixing method should be supplied.

Hipped roofs constructed with trussed rafters typically require a series of diminishing mono-pitched trusses supported by a girder truss.

The bearing of mono-pitched trusses into shoes should be in accordance with Table 1, unless designed by an engineer in accordance with Technical Requirement R5.

Figure 1: Trussed trimmed rafters

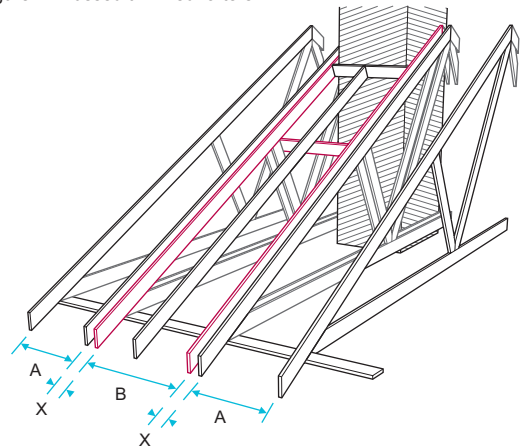

**Table 1:** Bearing length of mono-pitched trusses into shoes

Span	Minimum bearing length	Minimum thickness of trussed rafter
Less than 4m	50mm	35mm
4m or more	75mm	35mm

Ceiling finishes should be fixed according to the spacing of the support members and the thickness of the sheet.

Plasterboard should be fixed as follows:

- 9.5mm plasterboard should be fixed at a maximum support spacing of 450mm
- 12.5-15mm plasterboard should be fixed at a maximum support spacing of 600mm
- additional members will generally be required to support coverings and finishes where trusses are spaced further apart.

Where the width of a gable ladder exceeds that of the trussed rafter centres, noggings should be used to reduce the span of the roofing tile battens.

### Traditional cut roofs

For traditional cut roofs:

- the design should specify the details of each structural member and the method of fixing or jointing
- the roof should be in accordance with the design and members accurately located
- members should be fully supported and tied together where necessary, particularly where the roof is not a simple triangle
- temporary support to long span members should be used until framing is complete
- purlins and binders should be built in where necessary
- framing should be completed before coverings are installed.

**Table 2:** Basic timber members

Member	Notes
Valley rafter	Provides support for loads from both sections of the roof and should: <ul style="list-style-type: none"> <li>• be larger than ordinary rafters to take the additional load</li> <li>• provide full bearing for the splay cut of jack rafters</li> <li>• be provided with intermediate support where required</li> </ul>
Hip rafter	Provides spacing and fixing for jack rafters and should: <ul style="list-style-type: none"> <li>• have a deeper section than the other rafters to take the top cut of the jack rafters</li> </ul> Purlins should be mitred at hips and lip cut to accept the bottom of the hip rafter
Ceiling joist or ties	Provides support for the rafters and should: <ul style="list-style-type: none"> <li>• stop the walls and roof spreading outwards</li> <li>• provide support to the ceiling finish and walkways, etc</li> </ul>
Ridge	Provides fixings and spacing for the tops of the rafters
Purlin	Provides support to long span rafters to prevent deflection and increase stiffness
Struts	Provides support to purlins to prevent deflection and to transfer roof loads to the load-bearing structure below
Collar	Ties the roof together at purlin level
Ceiling binders and hangers	Provides support to long span ceiling joists
Pole plates	Similar to purlins, but used where ceiling joists are above wall plate level

Figure 2: Traditional roof members

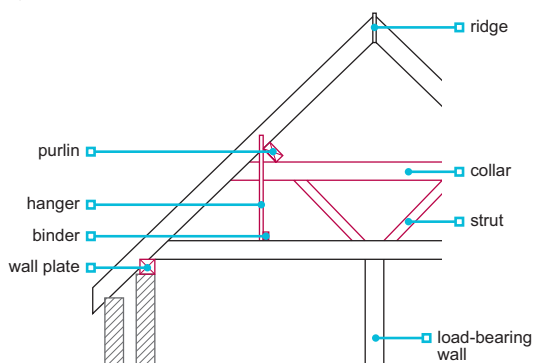
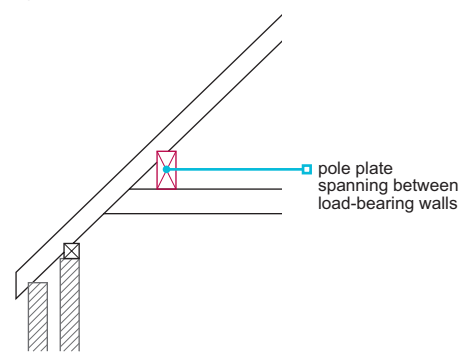

Figure 3: Pole plate



Generally sizes should be as Table 3, unless designed by an engineer in accordance with Technical Requirement R5.

**Table 3:** Typical sizes for timber members

Member	Minimum size
Struts	100mm x 50mm
Valley rafter	32mm thick
Ridges and hips	Rafter cut + 25mm

Figure 4: Types of rafter

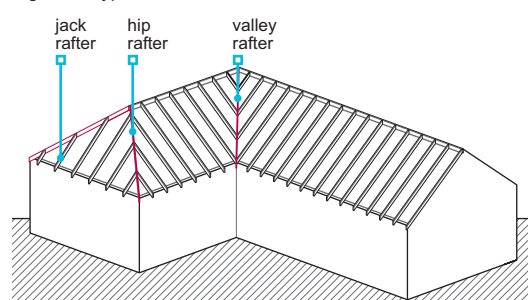

### 7.2.4 Protection of trusses

Also see: *Trussed Rafter Association Technical Handbook*

#### Trusses shall be protected from damage.

To avoid distortion and to prevent damage, trusses should be:

- protected against weather to prevent the corrosion of truss plates and the deterioration of the timber
- adequately ventilated during storage
- stored clear of the ground
- stored vertically and propped
- stored with level bearers under the joints
- carried upright (fasteners can loosen when carried flat).

Trussed rafters should not be cut, modified or repaired, except in accordance with written or drawn instructions issued and approved by the trussed rafter designer.

### 7.2.5 Durability

Also see: *Chapter 3.3*

#### Timber shall be of suitable durability.

The following timber members should be preservative treated or have adequate natural durability in accordance with Chapter 3.3 'Timber Preservation (natural solid timber)':

**Table 4:** Durability options for the following components

	Preservative treatment			Naturally durable species
	Treatment required	Use Class	Desired service life (years)	Select timber from a minimum Natural Durability Class <sup>(1)</sup> (heartwood only)
Porch posts	✓	3.1/3.2	60	2/1
Tiling battens	✓	2	60	2
Soffits	✓	3.1/3.2	30	3/2
Barge boards	✓	3.1/3.2	30	3/2
Fascias	✓	3.1/3.2	30	3/2

Notes

1 Where natural durability is used in lieu of preservative treatment, timber must be specified and selected as being heartwood only. Natural durability classes for the heartwood of commonly used timbers are available in BS EN 350 and Table 2 in Chapter 3.3.

Where the pitched roof is to include a fully supported weatherproofing membrane (ie, impervious coverings such as single ply membranes, bituminous membranes, etc) or continuous metal coverings, the risk of condensation is increased. The timber components listed in Table 5 should be preservative treated or have adequate natural durability.

**Table 5:** Durability options where fully supported weatherproofing membranes and continuous metal coverings are used

	Preservative treatment			Naturally durable species
	Treatment required	Use Class	Desired service life (years)	Select timber from a minimum Natural Durability Class <sup>(1)</sup> (heartwood only)
Rafters / trussed rafters	✓	2	60	2
Purlins	✓	2	60	
Ceiling joists	✓	2	60	
Bracings	✓	2	60	
Wall Plates	✓	2	60	
Battens	✓	2	60	

Note

1 Where natural durability is used in lieu of preservative treatment, timber must be specified and selected as being heartwood only. Natural durability classes for the heartwood of commonly used timbers are available in BS EN 350 and Table 2 in Chapter 3.3.

## 7.2.6 Wall plates

Wall plates and the roof structure shall be bedded and fixed to distribute and transmit loads, and to prevent uplift.

Trussed rafter roofs and traditional cut roofs should be supported on timber wall plates. Trussed rafters should only be supported at the junction between the ceiling tie and rafter, unless specifically designed otherwise, eg as a cantilever.

Wall plates should be:

- bedded to line and level
- fixed using nails or straps
- a minimum of 3m or extend over at least three joists, rafters or trusses
- joined using half-lapped joints, including at corners
- 38 x 100mm or in accordance with local practice.

Fixings used to connect the roof structure to the wall plate should be specified according to the roof construction and exposure of the site.

Where trussed rafter roofs are not subject to uplift, a minimum of two 4.5mm x 100mm galvanized round wire nails, skew nailed, one on each side of the trussed rafter, or truss clips (fixed in accordance with the manufacturer's instructions) are acceptable.

Where the roof is required to resist uplift, skew nailing is unlikely to provide sufficient strength, and appropriate metal straps should be used. Holding-down straps should be:

- provided according to the geographical location and construction type
- provided where the self-weight of the roof is insufficient against uplift
- provided in accordance with the design
- a minimum of 1m long with a cross section of 30mm x 2.5mm and spaced at a maximum of 2m centres (galvanised steel straps are generally acceptable) or proprietary straps and fixings
- fixed to the wall, or turned into a bed joint.

Fixings for straps should be:

- in accordance with the design
- of a material or finish which is compatible with the straps
- where into masonry, a minimum of four number, 50mm long No 12 wood screws (into suitable plugs)
- provided so that the lowest fixing is within 150mm from the bottom of the strap.

Proprietary straps should be:

- in accordance with Technical Requirement R3
- installed in accordance with manufacturer's recommendations.

Figure 5: Permissible truss projection

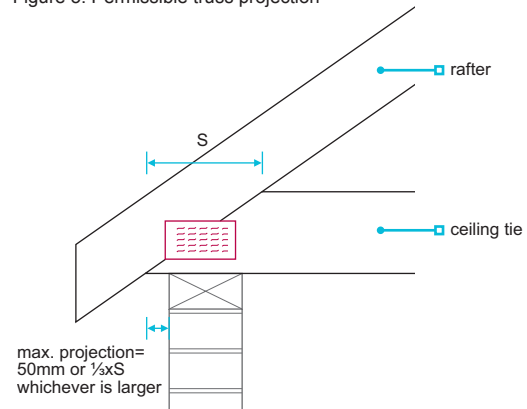

### 7.2.7 Joints and connections

Joints and connections shall be designed to ensure structural stability without undue movement or distortion.

Members should:

- be accurately cut to fit tightly
- not be damaged or split.

The following joints should be used at the main connections of traditional cut roof members:

#### Rafters to ceiling joists using a nailed lapped joint

The rafter should be birdsmouthed and skew nailed to the wall plate.

Figure 6: Rafter to ceiling joist connection

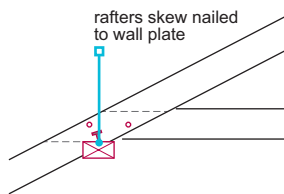

#### Rafter to purlin

A birdsmouth joint should be used, generally the purlin is fixed vertically.

Figure 7: Rafter to purlin connection

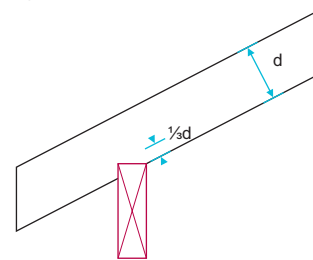

#### Purlin connections

Support should be provided directly under the joint or a scarf joint used. Scarf joints should be made near to a strut so that the joint supports the longer span.

Figure 8: Purlin connection

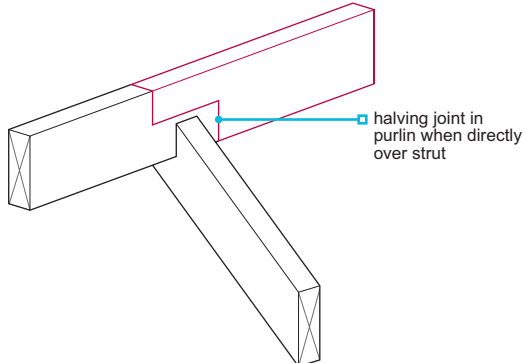

#### Scarf joint

Used to support the long span of the purlin.

Figure 9: Scarf joint

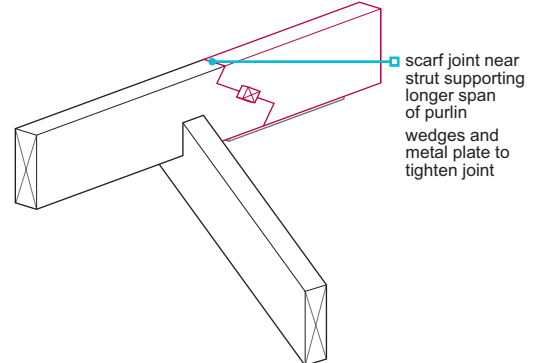

#### Hipped roof joints

Angle ties should be used at the corners of hipped roofs to prevent the wall plates from spreading.

Where hip rafters are heavily loaded, eg carrying purlins, they should be jointed using dragon ties, or similar, to prevent the hip rafter spreading.

Figure 11: Dragon tie

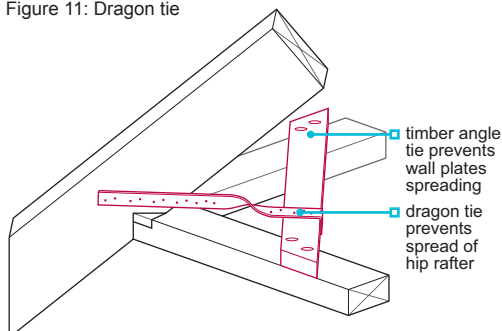

Figure 10: Angle tie

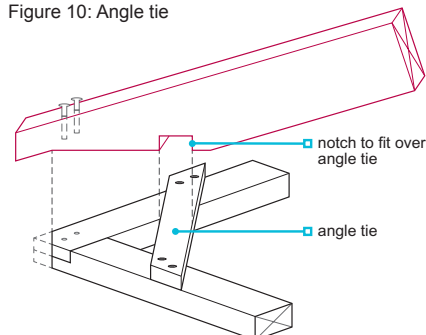
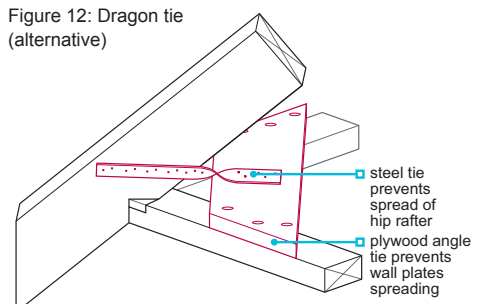

Figure 12: Dragon tie (alternative)



### Diminishing truss support

Diminishing trusses should be adequately supported by one of the following:

- by having a splayed bottom chord to ensure correct seating on the rafter or
- by sitting on a continuous binder which is splayed to receive the diminishing truss (Figure 13) or
- by sitting on 25mm x 38mm x 300mm long battens which are splayed to receive the diminishing truss (Figure 14) or
- proprietary diminishing support brackets assessed in accordance with Technical Requirement R3.

Figure 13: Diminishing truss supported by continuous binders

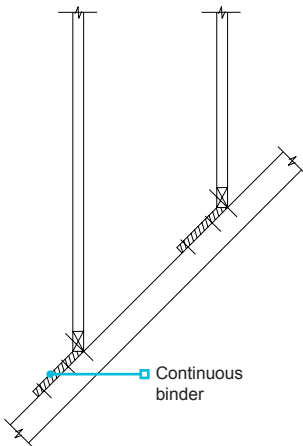
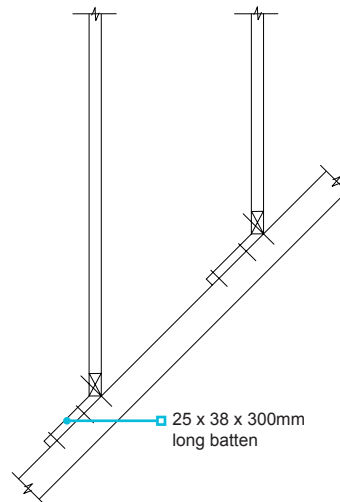

Figure 14: Diminishing truss supported on long battens



## 7.2.8 Restraint

Also see: Chapter 6.1

**Adequate restraint shall be provided to support the structure, distribute roof loads and prevent wind uplift. Strapping shall be of adequate strength and durability, and fixed using appropriate fixings.**

Restraint straps, or a restraining form of gable ladder, should be used where required to provide stability to walls, and be installed in accordance with the design.

Lateral restraint straps should be located:

- for homes up to and including three storeys (two storeys in Scotland), at a maximum spacing of 2m
- for homes four storeys (three storeys in Scotland) or over, fixed at a maximum spacing of 1.25m.

Lateral restraint straps should be fixed to the roof structure by either:

- fixing to solid noggings using a minimum of four 50mm x 4mm steel screws or four 75mm x 4mm (8SWG) round nails, with one fixing in the third rafter (Figure 15), or
- fixing to longitudinal bracing members using eight 25mm x 4mm steel screws evenly distributed along the length of the strap (Figure 16). Alternatively, 100mm x 25mm timber members, fixed over four trusses and nailed in accordance with Clause 7.2.9 can be used where the position of the strap does not coincide with a longitudinal binder.

Figure 15: Lateral restraint strap secured to timber blocking

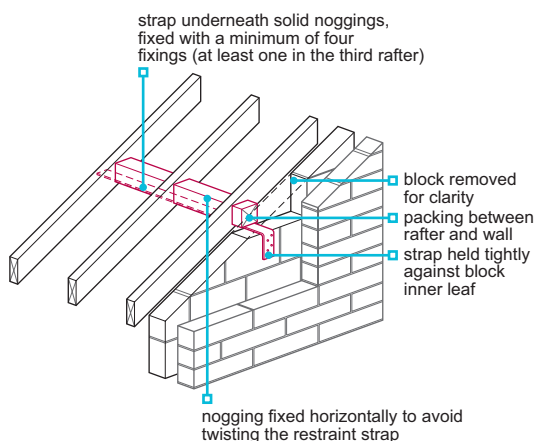
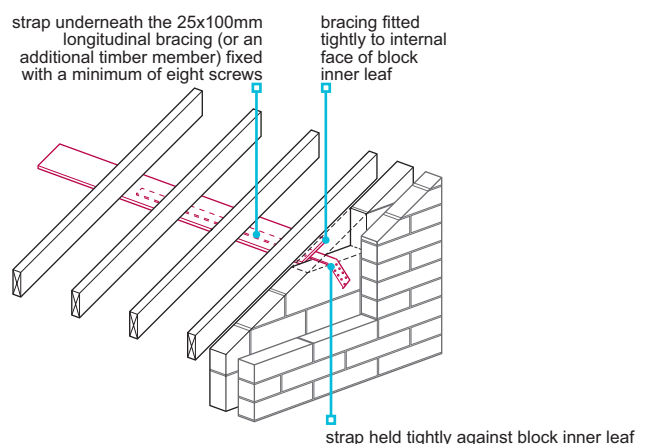

Figure 16: Lateral restraint strap secured to longitudinal bracing



Lateral restraint straps should be:

- ordered and supplied according to the design, ie, the correct length and number of bends and twists
- provided at rafter level on gable walls, where the home is of masonry construction (larger or separating walls may require restraint at ceiling level)
- protected against corrosion in accordance with BS EN 845-1 Clause 6.1.11 Table 4 (sherardised straps or fixings are not acceptable in Northern Ireland and the Isle of Man)
- of sufficient length to be fixed to a minimum of three trusses
- a minimum size of 30mm x 5mm and have a minimum anchorage downturn to 100mm (or proprietary straps)
- fixed with the downturn on a substantial piece of blockwork, preferably fitted over the centre of an uncut block
- in accordance with BS EN 1995-1-1, where the home is of timber frame construction.

In framed roofs, as an alternative, purlins and pole plates can be used to provide restraint where the timber abuts a gable construction. Where purlins are used to provide restraint, the maximum permissible spacing is 2m unless the design shows otherwise.

Gable ladders can also be used to provide restraint to the external wall where:

- forming part of the structural design
- there is blocking between the last trussed rafter and the inner leaf (maximum 2m spacing) or the longitudinal bracing is in contact with the inner leaf (maximum 2m spacing). Additional intermediate boards may need to be provided, where bracings are more than 2m apart and where homes are four storeys (three storeys in Scotland) or over
- the soffit board is cut carefully and then fixed securely to restrain the outer leaf.

Proprietary straps should be:

- in accordance with Technical Requirement R3
- installed in accordance with manufacturer's recommendations.

Figure 17: Restraint by gable ladder – masonry

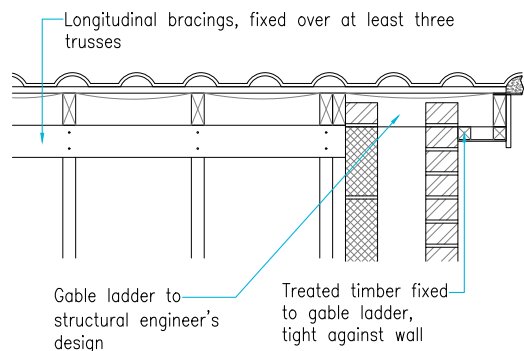

### 7.2.9 Bracing for trussed rafter roofs

Also see: BS EN 1995-1 and PD 6693-1

**Trussed rafters shall be suitably braced to support applied loads and self-weight without undue movement. Issues to be taken into account include:**

- |                         |                       |
|-------------------------|-----------------------|
| a) general requirements | c) mono-pitched roofs |
| b) duo-pitched roofs    | d) attic roofs.       |

For the purposes of this chapter, the guidance and use of standard trussed rafter bracing applies to all homes designed within the parameters set out below. For large houses with truss spans of over 12m, homes with complex roofs or roofs near exposed sites, the bracing should be designed by an engineer in accordance with Technical Requirement R5.

Standard trussed rafter bracing, in accordance with Table 6, is generally acceptable, where the home:

- has a rectangular roof (including hip ends) and is either a duo-pitched or a mono-pitch structure
- is not taller than 8.4m (to the underside of the ceiling tie)
- is braced in accordance with this chapter
- is braced according to the conditions of the site and in accordance with the design
- does not have trusses which span more than 12m
- has trusses which are only supported at each end
- does not have unsupported masonry spanning more than 9m (between buttressing walls, piers or chimneys)
- has a ceiling of plasterboard directly under each truss (where there is no plasterboard, ie, garages, additional diagonal ceiling bracing and longitudinal binder bracing at each ceiling node point is required).

**Table 6:** Location, height and span for standard bracing conditions for buildings at site altitudes ≤150m

	Roof type		Duo-pitch						Mono-pitch								
	Max pitch		35°			30°			35°			30°			25°		
	Storeys		1	2	3	1	2	3	1	2	3	1	2	3	1	2	3
Maximum span (m)	England <sup>(1)</sup> and Wales <sup>(1)</sup>	Wind zone A <sup>(2)</sup>	11.3	9.3	8.9	12	11.6	10.5	5.7	3.0	4.5	6.9	5.9	5.3	8.5	7.2	6.6
	Scotland <sup>(1)</sup> upto Glasgow and Aberdeen	Wind zone B <sup>(2)</sup>	9.4	8.1	7.6	11.6	10.2	9.1	5.0	4.0	3.8	5.9	5.2	4.5	7.2	6.4	5.7
	Scotland <sup>(1)</sup> upto Oban and Inverness	Wind zone C <sup>(2)</sup>	8.7	6.9	6.4	10.3	8.9	7.8	4.4	3.7	3.2	5.2	4.5	3.9	6.5	5.7	5.0
	Scotland <sup>(1)</sup> areas north of Isle of Mull and Broro	Wind zone D <sup>(2)</sup>	7.7	6.4	5.4	9.1	7.8	6.7	3.8	3.2	2.7	4.5	3.9	3.3	5.8	5.0	4.0
	Northern Ireland <sup>(1)</sup> and the Isle of Man	Wind zone B <sup>(2)</sup>	9.4	8.1	7.6	11.6	10.2	9.1	5.0	4.0	3.8	5.9	5.2	4.5	7.2	6.4	5.7
	Northern Ireland <sup>(1)</sup> areas north west of Ballymena	Wind zone C <sup>(2)</sup>	8.7	6.9	6.4	10.3	8.9	7.8	4.4	3.7	3.2	5.2	4.5	3.9	6.5	5.7	5.0

Notes

- 1 For details of area specific wind zoning please refer to PD6693-1.
- 2 Wind zones in accordance with PD6693-1.

Where trussed rafter designs are outside the parameters above, the guidance in PD6693-1 should be followed.

### General bracing requirements

Roof bracing should be:

- in accordance with this chapter or PD6693-1
- in accordance with the design and not altered without prior approval from the designer
- appropriate for the site (for large houses with truss spans of over 12m, homes with complex roofs or roofs near exposed sites, the bracing should be designed by an engineer in accordance with Technical Requirement R5)
- completed before the roof covering is laid
- provided using a minimum timber size of 100mm x 25mm (3mm tolerance)
- nailed twice to each rafter it crosses; fixings should be 3.35mm x 65mm (10 gauge) galvanized round wire nails or minimum 3.1mm x 75mm mechanically driven gun nails
- where braces and binders are not continuous, they should be lap jointed and nailed to a minimum of two trusses.

Figure 18: Roof bracing – lap joint

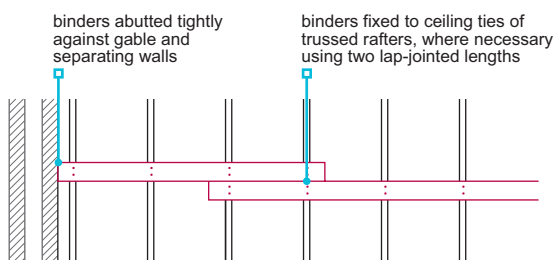

When bracing pitched roofs:

- diagonal and longitudinal bracing should be provided at rafter level (this may be omitted where sarking sheets or boards are used, eg chipboard, plywood or OSB, which are fixed to each trussed rafter with 3mm x 50mm galvanised round wire nails at 200mm spacing)
- diagonal and chevron bracing should pass across each rafter in the roof, however, small gaps, such as two trussed rafters between sets of bracing, or one trussed rafter adjacent to gable or separating walls, is permitted in the middle of an otherwise fully braced roof
- longitudinal bracing members should extend the full length of the roof, tightly abut gable and party walls and permit diagonal bracing to pass (they may be lap-jointed providing the overlap is nailed to a minimum of two trussed rafters)
- there should be a minimum of four diagonal rafter braces in each roof; in narrow fronted roofs (Figure 22) and mono-pitched roofs, where the braces cross, the intersection detail (Figure 23) should be used
- the diagonal bracing should extend over and be directly fixed to the wall plate, fixings should be 3.35mm x 65mm (10 gauge) galvanized round wire nails or minimum 3.1mm x 75mm mechanically driven gun nails, see Figure 19. Where the bracing cannot be directly fixed to the wall plate the bracing should be terminated as detailed in PD6693-1:2019, Figure E.9.

Figure 19: Roof bracing – wall plate connection

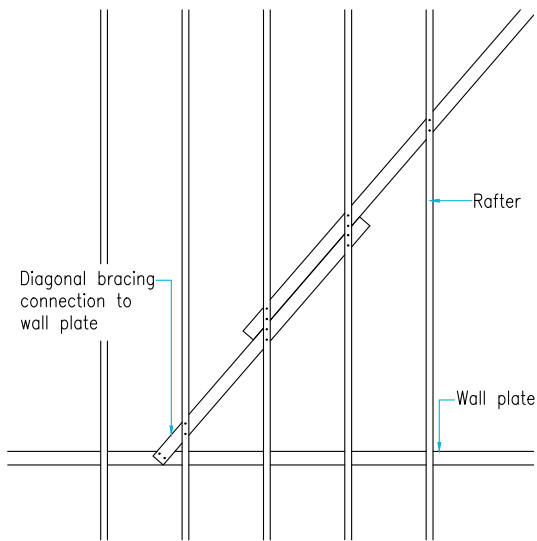

### Duo-pitched roofs

#### Diagonal bracing for duo-pitch trusses

Applicable to all trussed rafter roofs unless sarking sheets or boards, are used.

Diagonal bracing should also be provided in-between hipped ends, where the length of roof between the hip ends exceeds 1.8m.

Diagonal rafter bracing should be approximately 45° to the rafters on plan.

Figure 20: Diagonal rafter bracing – square roofs

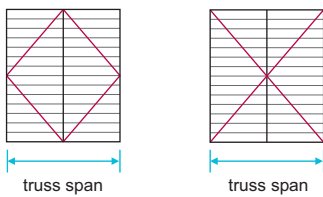

Figure 21: Diagonal rafter bracing – larger roofs

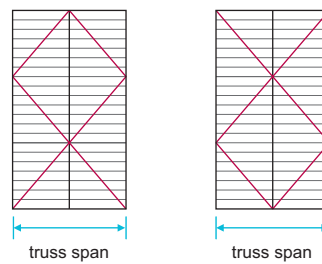
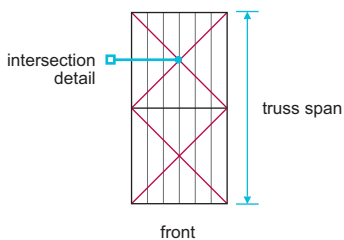

Figure 22: Diagonal rafter bracing – narrow fronted roofs



Intersection details should be formed by:

- 22mm x 97mm x 600mm timber splice plate
- nailing, using a minimum of four 3.35mm x 65mm galvanised round wire nails or minimum 3.1mm x 75mm mechanically driven gun nails to each side of the intersection, with nails driven through bracing and clenched over.

Figure 23: Intersection detail

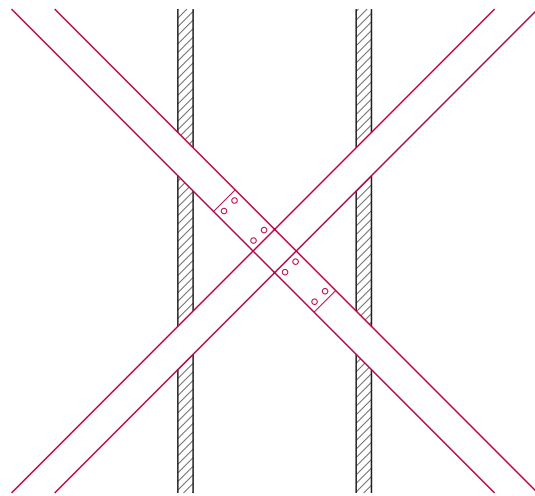

### Longitudinal bracing member at ridge node point

Applicable to all trussed rafter roofs. Not necessary where sarking sheets or boards are used.

Figure 24: Longitudinal bracing – ridge node

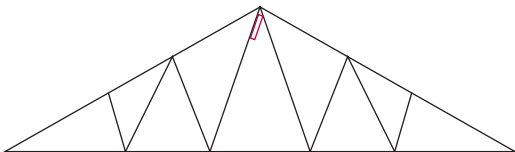

### Longitudinal bracing member at rafter node point

Applicable to all rafter node points. Not necessary where:

- spacing between braced nodes is less than 4.2m, or
- sarking sheets or boards are used.

Figure 25: Longitudinal bracing – rafter node

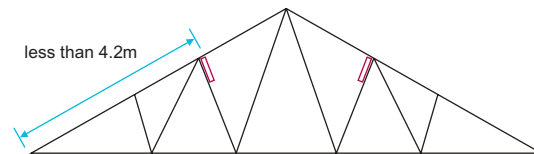

### Longitudinal binders at ceiling node points

Applicable to all ceiling node points. Not necessary where the spacing between braced nodes is less than 3.7m.

Figure 26: Longitudinal binders – ceiling node

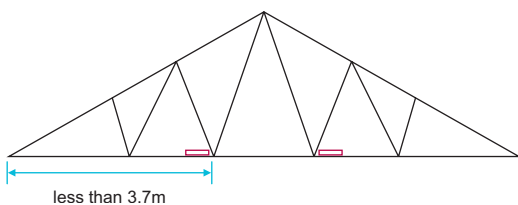

### Chevron bracing between webs

Chevron bracing should be:

- provided where the span exceeds 8m
- at approximately 45°
- nailed to at least three trusses.

Figure 27: Chevron bracing – duo pitched roof

KEY:

- ▭ Chevron bracing position where span exceeds 8m
- ▭ Additional chevron bracing position where span exceeds 11m

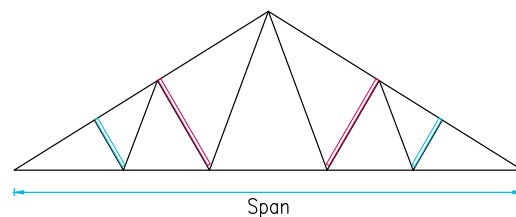

For duo-pitch roofs over 11m span, chevron bracing should be designed by an engineer in accordance with Technical Requirement R5.

### Mono-pitched roofs

#### Diagonal bracing for mono-pitch trusses

Applicable to all mono-pitched trussed rafter roofs unless sarking sheets or boards are used.

Diagonal rafter bracing should be approximately  $45^\circ$  to the rafters on plan.

Figure 28: Mono-pitch truss - diagonal rafter bracing

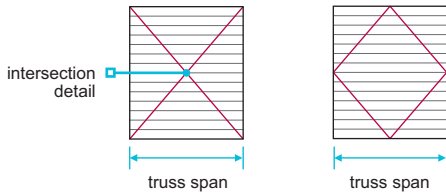

#### Longitudinal bracing to mono-pitch trusses

Longitudinal bracings should be located at the apex and either:

- all other node points (excluding support points); or
- where intermediate longitudinal bracing members are omitted, the resultant spacing between longitudinal braced node points does not exceed 4.2 m measured along each rafter and 3.7 m measured along each ceiling tie.

Figure 30: Mono-pitch truss – longitudinal bracing

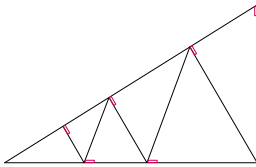

#### Diagonal bracing to end vertical member of mono-pitch trusses

Applicable where the truss is not restrained by:

- a masonry wall, or
- cladding, ie, plywood.

Figure 29: Mono-pitch truss - diagonal bracing to end vertical member

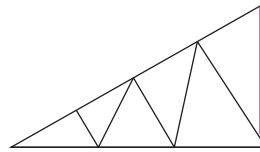



#### Chevron bracing between webs

Chevron bracing should be:

- provided where the span exceeds 5m
- at approximately  $45^\circ$
- nailed to at least three trusses.

Figure 31: Mono-pitch truss - chevron bracing

KEY:

-  Chevron bracing position where span exceeds 5m
-  Additional chevron bracing position where span exceeds 8m

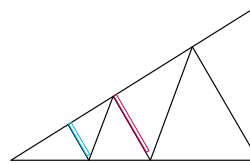

For mono-pitch roofs over 8m span, chevron bracing should be designed by an engineer in accordance with Technical Requirement R5.

## Attic trusses

Attic trusses should be braced in accordance with the design.

### Diagonal bracing

Applicable to all attic trussed rafter roofs unless sarking sheets or boards are used.

Diagonal bracing is required:

- at each gable end at approximately 45° on plan
- at intervals along the roof to ensure each truss is braced
- to be fixed to the underside of the rafters (where diagonal bracing passes through the room space, ceiling boards can be fixed over the diagonal bracing onto battens fixed to the rafters on each side of the bracing).

### Diaphragm bracing

Where the diagonal bracing passes through the room space and needs to be interrupted to allow boarding to be fixed without battening out the rafters the following options may be used:

- continuous internal 9mm plywood or OSB sheathing (see Table 9) minimum 900mm width, as shown in Figure 33, face fixed to underside of rafters for the full length of the roof, or
- diaphragm bracing closely fitted between the rafters as shown in Figure 34 and Figure 35. The bracing should be 9mm plywood or OSB sheathing (see Table 9), at least 1200mm long fixed to a 50mm x 50mm timber framework.

Figure 34: Attic truss – diaphragm bracing

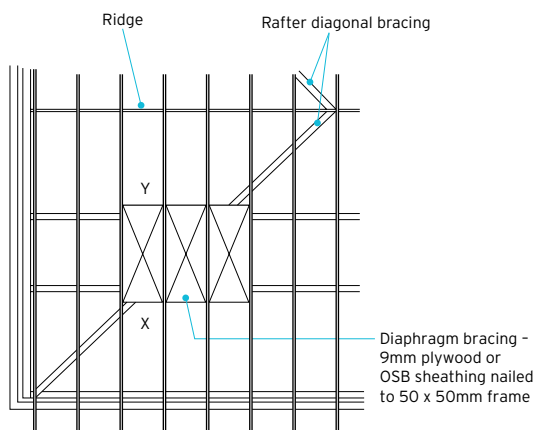

### Longitudinal bracing

Longitudinal bracing is required:

- at node points (excluding support points).

Figure 32: Attic truss - diagonal bracing

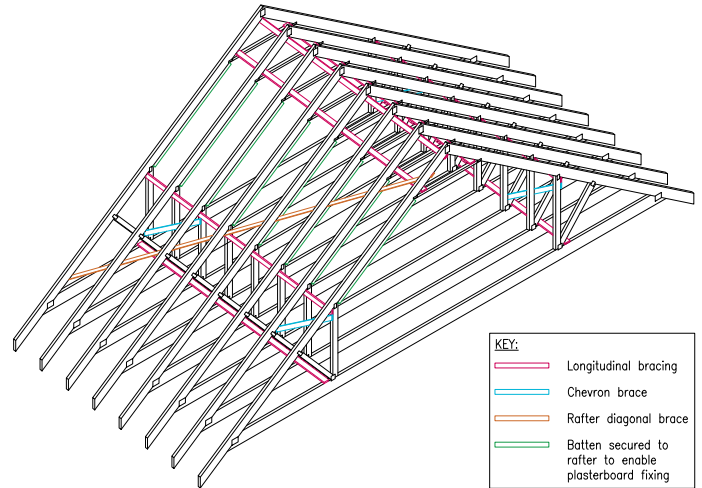

Figure 33: Attic truss – diaphragm bracing

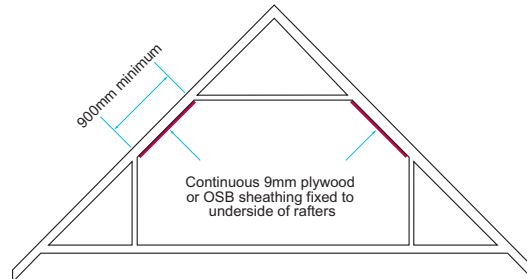

Figure 35: Attic truss – diaphragm bracing

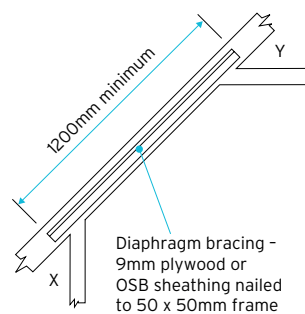
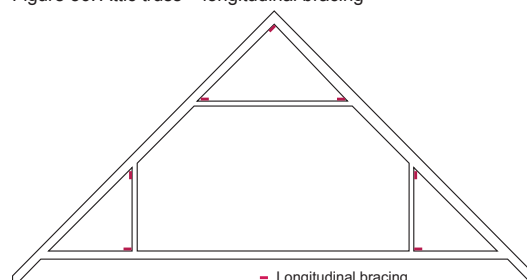

Figure 36: Attic truss – longitudinal bracing



Also see: Chapter 6.4

### 7.2.10 Strutting for site formed attic trusses and cut roofs that form a floor

**Strutting to site formed attic trusses shall be provided to support the applied loads and self-weight without undue movement or distortion.**

Strutting should be provided:

- in accordance with the design
- where the span between the node points which form the width of the floor of the attic truss exceeds 2.5m
- where the span between the supports to a floor within a cut roof exceeds 2.5m
- using herringbone (38mm x 38mm timber) or solid strutting (a minimum of 0.75x the depth of the floor and a minimum of 38mm thick).

**Table 7:** Provision of strutting

Span of floor	Rows of strutting
Under 2.5m	None required
2.5m-4.5m	One (at centre of span)
Over 4.5m	Two (at equal spacing)

### 7.2.11 Support for equipment

**Permanent equipment in roof voids shall be adequately supported.**

Where equipment (eg water tanks and MVHR fan units) is located in the roof void, the structure should be designed in accordance with PD 6693-1 and the truss manufacturer's recommendations, to support the additional load. Platforms supporting permanent equipment, should be positioned with a minimum clearance of 50 mm between the top of the insulation and the underside of the platform, to ensure a clear ventilation space.

### 7.2.12 Access

Also see: Clause 7.2.15

**Roof voids shall be provided with suitable access.**

Access to roof voids should be provided to allow for periodic inspection, maintenance and removal of permanent equipment.

Access should:

- be provided to the main roof space and to voids which contain permanent equipment (eg heating, water storage, energy producing and ventilation equipment, etc), service connection boxes or connection points for TV aerials, etc
- permit the removal of permanent equipment located in the roof space
- have a minimum opening width of 520mm in each direction
- not be located directly over stairs or in other hazardous locations
- include securely fixed boarded walkways between the opening and the permanent equipment and at each piece of permanent equipment, a minimum 1m<sup>2</sup> platform should be provided to facilitate maintenance
- boarded walkways and working platforms should be securely fixed with a minimum clearance of 50 mm between the top of the insulation and the underside of the walkway to ensure a clear ventilation space.

Access may not be required where a void does not contain any permanent equipment, service connection boxes or connection points for TV aerials, etc where:

- the main roof consists of only a small void below the ridge where the raised collar is less than 2m in length
- roof cassette systems are used in forming room-in-roof and the length of the raised collar is over 2m and the floor to ceiling dimension below the ceiling is over 2.4m
- small voids are present in the eaves (including those which contain water pipes only).

Access hatches should be in accordance with Clause 7.2.15. Where an access hatch is required to provide fire resistance, the fire-resistance period should be supported by test evidence.

### 7.2.13 Dormer construction

Also see: Chapter 3.3

Dormers shall be adequately constructed. Issues to be taken into account include:

- a) structure
- b) ventilation
- c) insulation
- d) control of condensation
- e) proprietary dormers.

#### Structure

Figure 37: Dormer – rafter supported

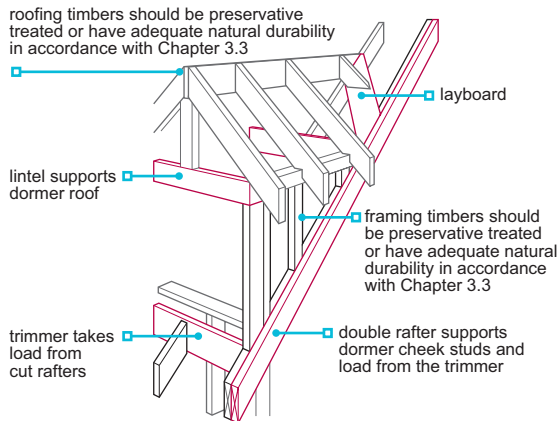
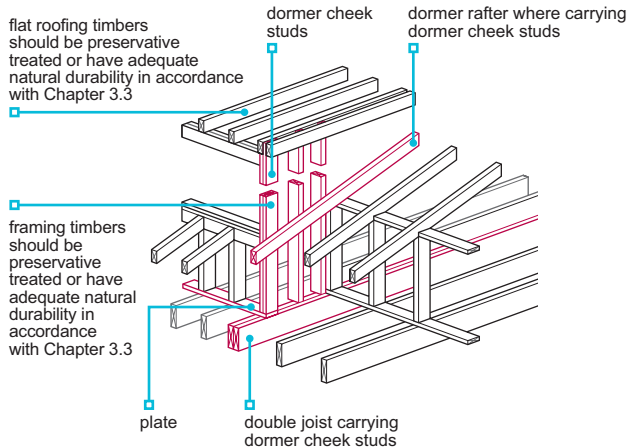

Figure 38: Dormer – floor supported



Site formed dormer roofs:

- should be constructed in accordance with the design
- cheek studs should be supported by either a double rafter or a double floor joist
- trimming members should be large enough to support additional loads from the main roof members, dormer framing and cladding
- which are unusually large or of bespoke design should have an appropriate support designed by a suitable qualified person or a structural engineer in accordance with Technical Requirement R5
- should have a suitable lintel provided over the opening
- lintels should be structurally independent from the window frame
- timbers should be preservative treated or have adequate natural durability in accordance with Table 1 of Chapter 3.3 'Timber preservation (natural solid timber)'
- should have roofs braced in accordance with this chapter, where roof trusses are used
- should have roof coverings in accordance with this chapter or Chapter 7.1 'Flat roofs, terraces and balconies'.

The external walls of a site formed dormer:

- should be sheathed and protected by a suitable breather membrane
- have a drained and ventilated cavity behind claddings, in accordance with Clause 6.2.10.

Lead, used to clad dormer cheeks, should be detailed in accordance with the Lead Sheet Training Academy 'The complete manual' and be:

- a minimum Code 4 (blue) or 5 (red) in a sheltered to moderate exposure zone or
- code 5 (red) or 6 (black) in a severe exposure zone.

### Ventilation

Pitched roofs shall be adequately ventilated to limit the risk of interstitial condensation. For cold roofs, ventilation should be provided from eaves to eaves or at ridge level, in accordance with Table 8.

Figure 39: Ventilation to dormer pitched roofs

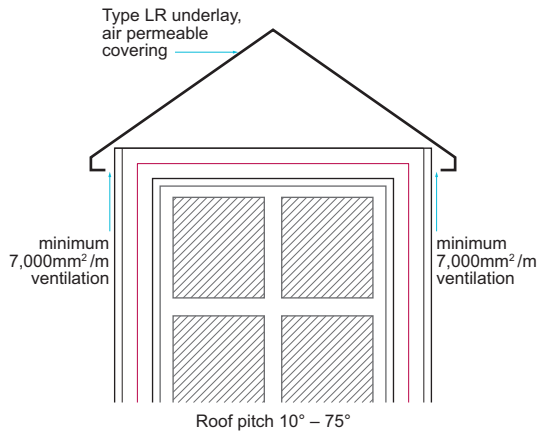
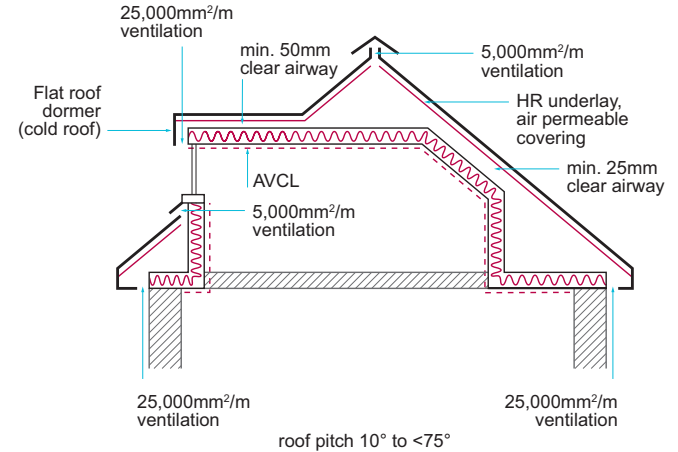

Figure 40: Room in roof (flat cold roof dormer)



**Table 8:** Dormer pitched roof ventilation requirements

Cold roof with air permeable outer weatherproof covering			
Roof pitch	Underlay type	Ceiling type	Minimum eaves ventilation
10° to 15°	Type HR	Any	25 000mm <sup>2</sup> /m
>15° and <75°	Type HR <sup>(1)</sup>	Any	10 000 mm <sup>2</sup> /m
10° to 75°	Type LR	Normal <sup>(2)</sup>	7000 mm <sup>2</sup> /m
		Well-sealed <sup>(2)</sup>	3000 mm <sup>2</sup> /m <sup>(3)</sup>

Notes:

1. High level vent 5000 mm<sup>2</sup>/m based on the longest horizontal dimension should be provided where the roof pitch exceeds 35°.
2. A normal ceiling typically has an air permeability of 300 mm<sup>2</sup>/m<sup>2</sup> (0.3%). A well-sealed ceiling conforms to Clause 12.4.2 of BS 5250 and BS 9250, and typically has an air permeability of not more than 30 mm<sup>2</sup>/m<sup>2</sup> (<0.03%).
3. Alternatively, a high-level vent 5 000 mm<sup>2</sup>/m based on the longest horizontal dimension of roof can be provided.

Where air impermeable outer weatherproof coverings are used, please refer to Clause 7.2.15 for guidance on roof ventilation strategies.

Flat roof dormers should:

- have falls to the front or sides
- be either of warm deck or cold deck construction (in accordance with BS 5250)
- be ventilated where of cold deck construction in accordance with Clause 7.1.11
- be constructed in accordance with Chapter 7.1 'Flat roofs, terraces and balconies'.

### Insulation

Dormer roofs and cheeks should be insulated to meet the requirements of the Building Regulations.

### Control of condensation

To limit interstitial condensation, site formed dormers should incorporate an air and vapour control layer to the walls.

Air and vapour control layers should also be provided to flat roofs, in accordance with Chapter 7.1 and are recommended to be applied to the warm side of the insulation within pitched roofs.

Further guidance on air and vapour control layers can be found in Clause 7.2.15.

### Proprietary dormers

Proprietary dormers (eg glass reinforced plastic - GRP) should hold a satisfactory assessment by an appropriate independent technical approval's authority acceptable to NHBC.

Proprietary dormers should meet the Technical Requirements and:

- be suitably durable
- limit the risk of interstitial condensation occurring to the walls and roof
- be installed in accordance with certification requirements.

Walls and roofs of proprietary dormers should typically incorporate an air and vapour control layer. The air and vapour control layer specification should be in accordance with manufacturers requirements.

### 7.2.14 Underlay, sarking boards and sheets

**Underlay and sarking shall be provided to resist the passage of moisture.**

Underlay and sarking should:

- be in accordance with the manufacturer's recommendations
- take account of the type and fixing of the roof covering
- be used in accordance with relevant assessments.

In areas of severe exposure, a rigid sarking sheet or board with underlay is recommended.

**Table 9:** Acceptable materials for use as underlay and sarking

Material	Standard / requirement	Minimum material specification (where applicable)	Minimum material thickness (where applicable)
Solid timber tongue and grooved or square edged board	BS 1297		16 mm
Plywood	BS EN 636	BS EN 636 - 2S <sup>(2)</sup>	9 mm <sup>(1)</sup>
Chipboard	BS EN 312	Type P5	12 mm <sup>(1)</sup>
OSB	BS EN 300	OSB/3	9mm <sup>(1)</sup>
Type HR (>0.25MN/g) and Type LR (<0.25MN/g) underlay	BS EN 13859-1	Class W1	
	BS 8747	1F/5U	
Type LR - Low water vapour resistance (<0.25MN/g) and air permeable underlay (min. air permeability of 34m <sup>3</sup> /m <sup>2</sup> .h at 50 Pa)	Technical Requirements R3 <sup>(3)</sup>	Class W1	
Proprietary products	Technical Requirements R3 <sup>(3)</sup>		

Notes:

1. Minimum thickness suitable only where roof coverings (eg slates and tiles) are independently supported on battens, secured to counter battens. Minimum thicknesses quoted, actual design requirements may differ.
2. S- Structural.
3. Propriety products should hold a satisfactory assessment by an appropriate independent technical approval's authority acceptable to NHBC.

Underlay should:

- be provided to all tiled and slated roofs
- not be left exposed to sunlight for longer than recommended by the manufacturer
- where fully supported on a sarking sheet which offers a high resistance to the passage of air or water vapour, such as plywood, OSB, chipboard, or tongue and grooved sarking boards, be treated as a type HR underlay for roof ventilation purposes
- be supported by a continuous fillet or proprietary eaves support tray, laid to inclined falls (see Figure 41), to prevent sagging (which can form a water trap)
- be securely fixed in accordance with manufacturers requirements
- at vertical laps, be fixed only over rafters, and at horizontal laps be held in place by battens. Where no batten is provided over a horizontal lap, the underlay manufacturers guidance should be sought
- be cut neatly to fit tightly around surface penetrations and not be torn, ie, where pipes project through the underlay
- be dressed into the gutter where exposed at eaves level, be UV resistant or of type 5U felt or a proprietary eaves guard used
- where traditional mortar pointing is used to bed ridge tiles, extend over the ridge, in accordance with Clause 7.2.19
- be detailed in accordance with manufacturer's requirements where proprietary ventilating ridge tiles or dry ridge systems are used
- continue over hips to form a 150mm minimum lap parallel with the hip rafter
- at abutments, be supported and turned up by a minimum of 100mm
- be draped to allow water to drain behind the tiling battens.

**Table 10:** Horizontal laps for unsupported and supported underlays

Pitch	Minimum horizontal laps	
	Unsupported underlay	Supported underlay
Less than 15°	225mm	150mm
15° and above	150mm	100mm

At valleys:

- the main roof underlay should be cut to the valley batten line
- a strip of underlay should be laid under the main roof underlay and held down by the valley battens (where used).

Figure 41: Underlay detailing

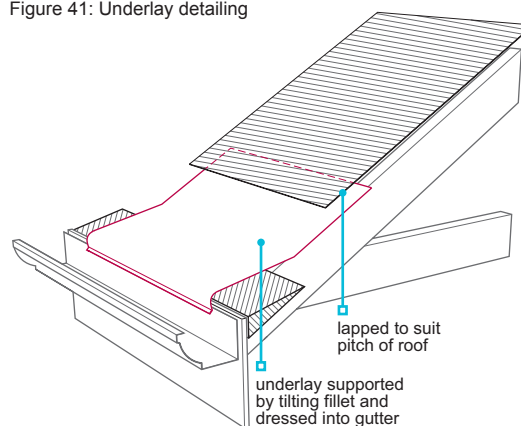

### 7.2.15 Ventilation, vapour control and insulation

Also see: Part 8.0, BS 5250

**Roofs shall have adequate precautions against condensation and cold. Issues to be taken into account include:**

- |                   |               |
|-------------------|---------------|
| a) ventilation    | c) insulation |
| b) vapour control | d) pipework.  |

#### Ventilation

This guidance on ventilation should be read in conjunction with the definitions table at the beginning of Chapter 7.2 'Pitched roofs'.

Pitched roofs should be adequately ventilated to limit the risk of interstitial condensation. Roof ventilation should be in accordance with BS 5250:2021.

The roof ventilation guidance in this clause is taken from BS 5250:2021 'Management of moisture in Buildings – Code of practice'. New-build homes can be at risk of a significant additional moisture load from the construction process and therefore roof-space condensation may occur during the first heating season. The builder may consider additional precautions than those stated below, to help reduce the potential for condensation during this period eg by providing 5000mm<sup>2</sup>/m high level ventilation in cold roof construction, where high level ventilation is not be required in the British Standard.

The roof ventilation strategy should be selected dependent upon:

- the roof covering ie, air permeable or air impermeable
- the underlay type ie, Type LR or Type HR
- the roof type ie, cold or warm roof
- the pitch of the roof
- ceiling type ie, normal or well-sealed (where applicable).

#### Roofing underlay

Roofing underlays, Type HR or Type LR, should be selected with consideration for the roof type, the outer weatherproof covering and the design of the property, in order to ensure that the required ventilation provision can be met.

Where a Type LR underlay is fully supported on sarking sheets or boards which offer a high resistance to the passage of air or water vapour, such as plywood, oriented strand board (OSB), chipboard, or tongue and grooved sarking boards, the Type LR underlay and sarking should be treated as a Type HR underlay, for roof ventilation purposes.

Where Type LR underlays are laid on open jointed square-edged sarking boards, typically 150 mm wide with a minimum 2 mm gap between each board, these may be treated as Type LR underlays, for roof ventilation purposes.

#### Air permeability of roof coverings

Manufacturers information should be checked to confirm the air permeability of the roof covering. BS 5534 'Slating and tiling for pitched roofs and vertical cladding' (Annex L) provides information on testing the air permeability of tiles or slates.

Where the permeability of the roof covering is unknown, the roof covering should be treated as air impermeable.

Where arrays of integrated solar roof panels are installed forming the roof covering, then the whole roof covering should be treated as air impermeable, unless the panel manufacturer is able to demonstrate their system is air permeable. Intergrated solar roof panel manufacturers may also require a larger air space beneath the panel, than stated in this Clause, to increase ventilation and cooling of the panel.

**Roof ventilation strategies**

Roof ventilation should:

- prevent the entry of birds, etc (fabrications with 3mm-10mm openings are acceptable)
- ensure that ventilation pathways remain clear, ie, not blocked by insulation or the structure
- have a spacer in the eaves to allow insulation to be installed over and beyond the wall plate to minimise the thermal bridge without blocking the ventilation path (the spacer should be of sufficient length to maintain ventilation throughout the thickness of the insulation)
- incorporate correctly sized, proprietary eaves ventilators, which are fixed in accordance with the manufacturer's instructions.

Figure 42: Typical eaves ventilation

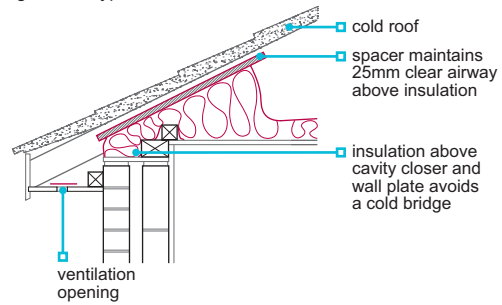

For the purposes of health and safety it may not be necessary to provide ventilation to small roof areas (3m<sup>2</sup> or less) over porches or bay windows. Where no roof ventilation is proposed, a condensation risk analysis should be undertaken to ensure the risk of interstitial condensation is mitigated. Alternative designs for small roofs maybe more appropriate, for example:

- warm roof designs or
- the use of air and vapour permeable underlays.

To avoid condensation in larger roofs, pitched roofs which incorporate insulation, should be designed to limit the risk of interstitial condensation. Guidance on roof ventilation strategies can be found using the flow chart below:

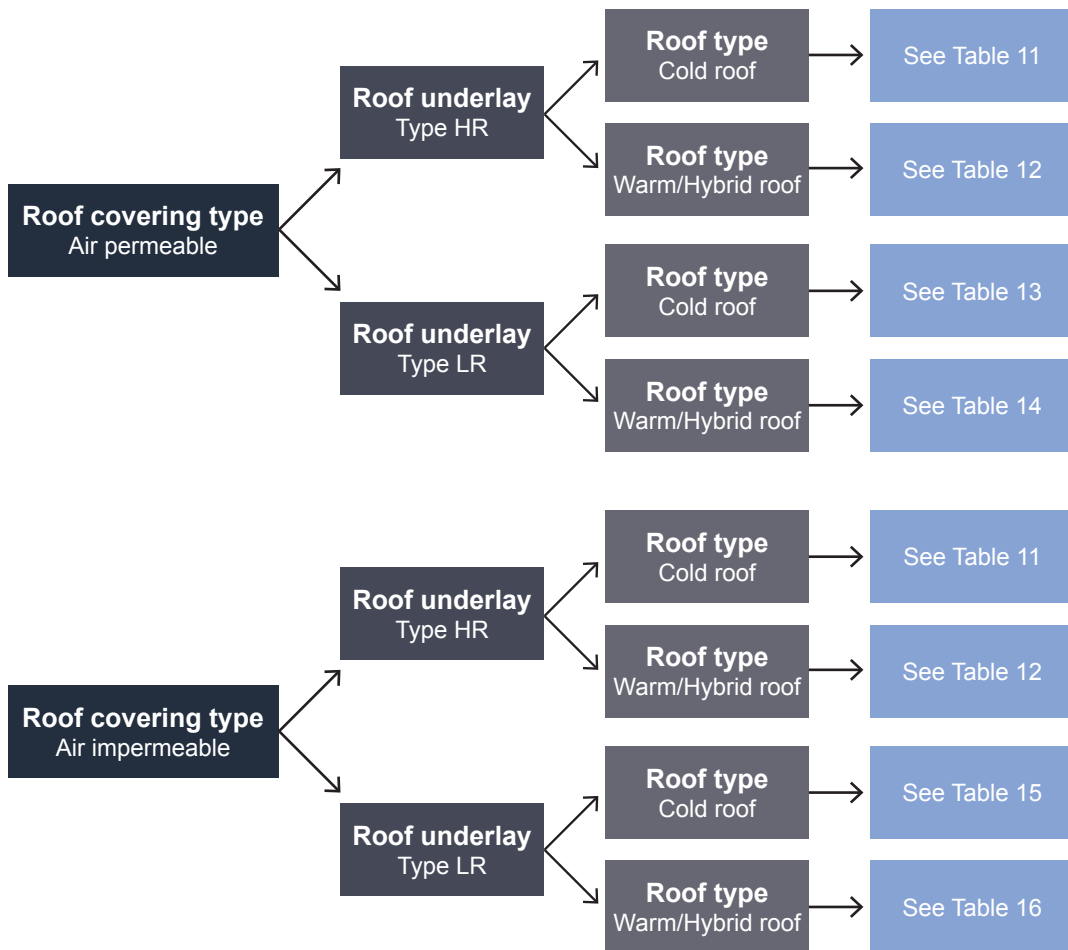

### Air permeable outer weatherproof coverings

This section provides guidance on the roof ventilation strategy where an air permeable outer weatherproof covering is used.

Outer weatherproof coverings of concrete and clay tiles are typically classed as air permeable, manufacturers information should be consulted.

**Table 11:** Cold roof ventilation (Type HR underlay and air permeable outer roof covering)

Roof pitch	Minimum eaves/ low level ventilation (underneath underlay)	Additional requirements
10° to 15°	25 000mm <sup>2</sup> /m	Additional 5000 mm <sup>2</sup> /m ridge or high level ventilation (underneath underlay), based on the longest horizontal dimension, should be provided where the roof pitch exceeds 35° or the roof span exceeds 10m, or the roof is a lean-to or mono pitch
>15° and <75°	10 000mm <sup>2</sup> /m	

Figure 43: Roof pitch 10° to 15°

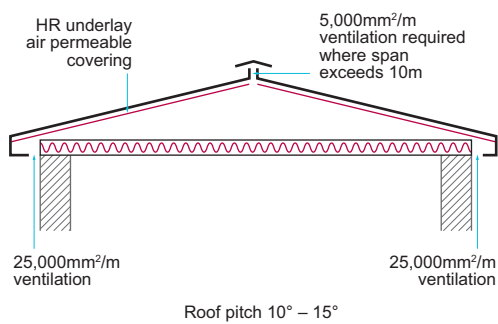

Figure 44: Roof pitch >15° and <75°

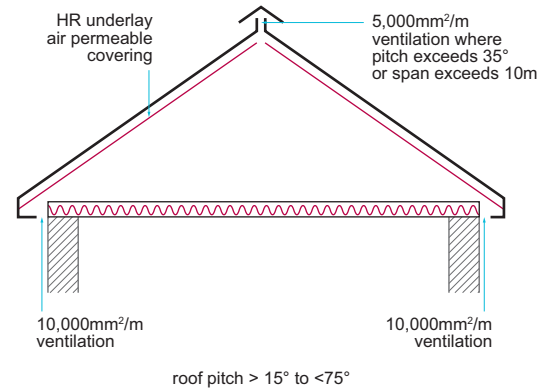
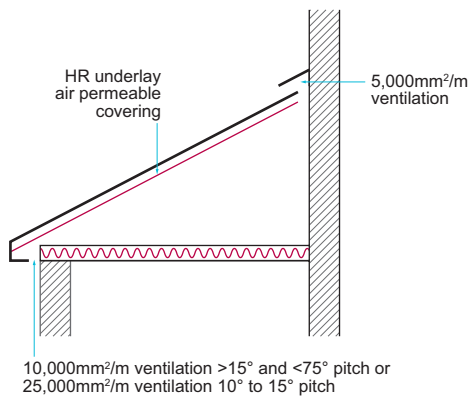

Figure 45: Mono-pitched roof



**Table 12:** Warm or hybrid roof ventilation (Type HR underlay and air permeable outer roof covering)

Roof pitch	Minimum eaves/ low level ventilation (underneath underlay)	Minimum ridge/ high level ventilation (underneath underlay)	Additional requirements
10° to <75°	25 000mm <sup>2</sup> /m	5000mm <sup>2</sup> /m	AVCL required Minimum 25mm clear ventilation pathway required <sup>(1)</sup>

Note:

1. Minimum 25mm clear ventilation pathway is measured from the lowest point of the underlay drape or underside of sarking.

Figure 46: Hybrid roof - Room-in-roof

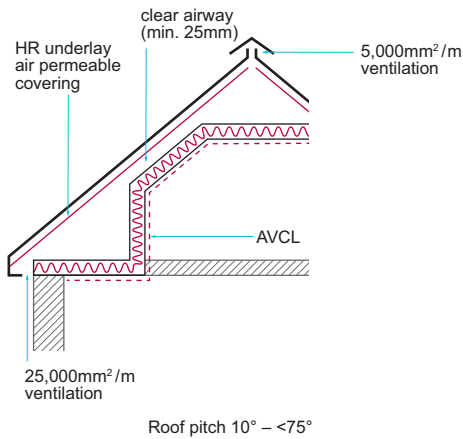

Figure 47: Hybrid roof - Room in roof (flat roof dormer)

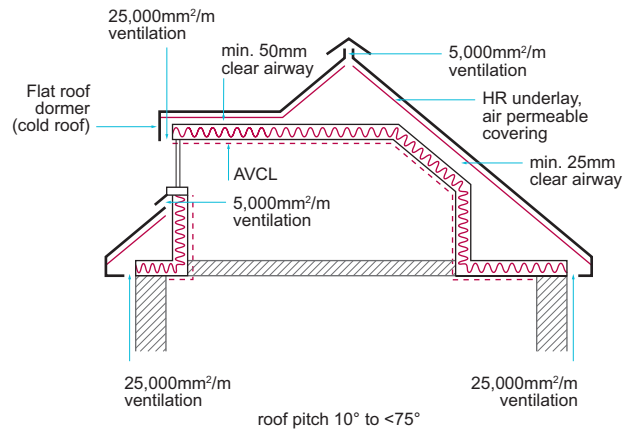
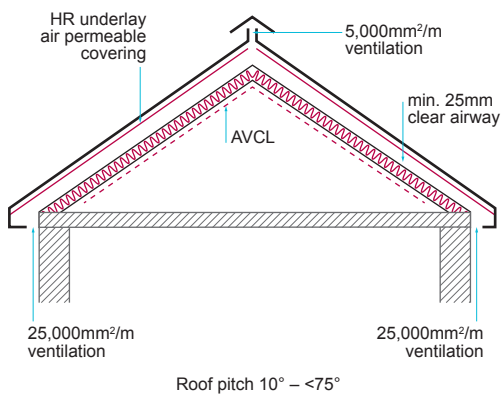

Figure 48: Warm roof



**Table 13:** Cold roof ventilation (Type LR underlay and air permeable outer roof covering)

Roof pitch	Ceiling type	Minimum eaves/low level ventilation (underneath underlay)
10° to <75°	Normal <sup>(1)</sup>	7000mm <sup>2</sup> /m
10° to <75°	Well-sealed <sup>(1)</sup>	3000mm <sup>2</sup> /m <sup>(2)</sup>

Notes:

1. A normal ceiling typically has an air permeability of 300 mm<sup>2</sup>/m<sup>2</sup> (0.3%).  
A well-sealed ceiling conforms to BS 9250 and typically has an air permeability of not more than 30 mm<sup>2</sup>/m<sup>2</sup> (≤0.03%).
2. Alternatively, a high-level vent 5000 mm<sup>2</sup>/m based on the longest horizontal dimension of roof can be provided.

Figure 49: Cold roof – LR underlay with air permeable covering

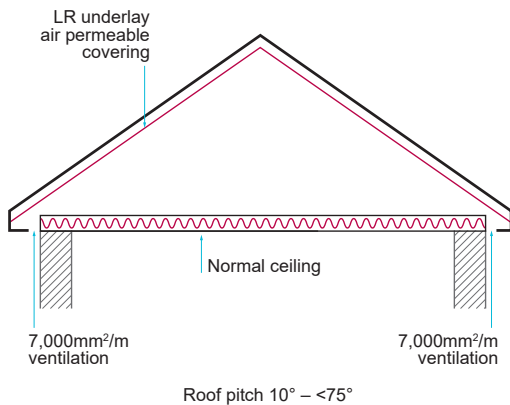

Where no ventilation is proposed to the cold roof void with air permeable outer roof coverings, the roofing underlay (Type LR) must be a low water vapour resistance and air permeable underlay and hold current certification for use in a non-ventilated application, from an appropriate independent technical approvals body, acceptable to NHBC. Such membranes should have a water vapour resistance,  $s_d$ , not exceeding 0.05 m (0.25 MN·s/g) and a minimum air permeability of 34m<sup>3</sup>/m<sup>2</sup>.h at 50 Pa, or more.

**Table 14:** Warm or hybrid roof ventilation (Type LR underlay and air permeable outer roof covering)

Roof pitch	Roof type	Minimum eaves/ low level ventilation (underneath underlay)	Minimum ridge/ high level ventilation (underneath underlay)	Additional requirements
10° to <75°	Warm roof	None	None	AVCL required <sup>(1)</sup> Underlay drape should be maintained
10° to <75°	Hybrid roof	7000mm <sup>2</sup> /m	5000mm <sup>2</sup> /m	AVCL required A minimum 25mm clear ventilation pathway is required <sup>(2)</sup>

Notes:

- Where a continuous air and vapour control layer is impractical to install, an additional 25 000mm<sup>2</sup>/m eaves or low level ventilation and 5000mm<sup>2</sup>/m ridge or high level ventilation should be provided below the underlay. A minimum 25mm clear ventilation pathway is required below the underlay.
- Minimum 25mm clear ventilation pathway is measured from the lowest point of the underlay drape or underside of sarking.

Figure 50: Warm roof - LR underlay with air permeable covering

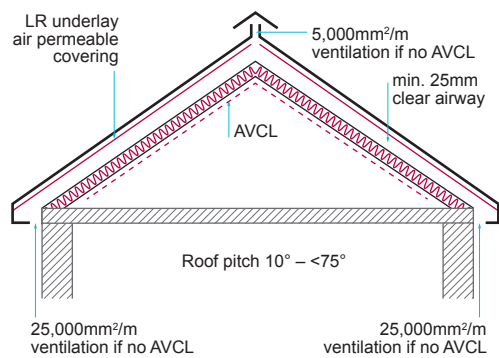
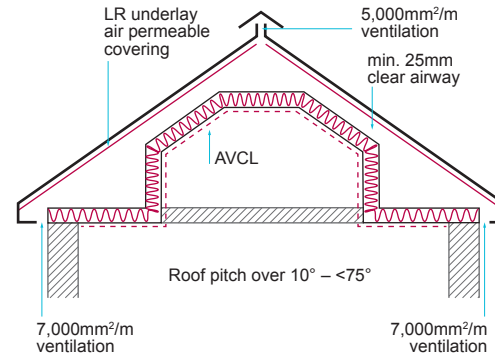

Figure 51: Hybrid roof - LR underlay with air permeable covering



### Cold Roof with flat roof apex

Where a cold pitched roof meets a cold flat roof, there is a risk of condensation occurring on the underside of the flat roof deck. Ventilation beneath the underlay, should therefore be provided in accordance with Figure 52 below.

Figure 52: Cold pitched roof with flat roof apex

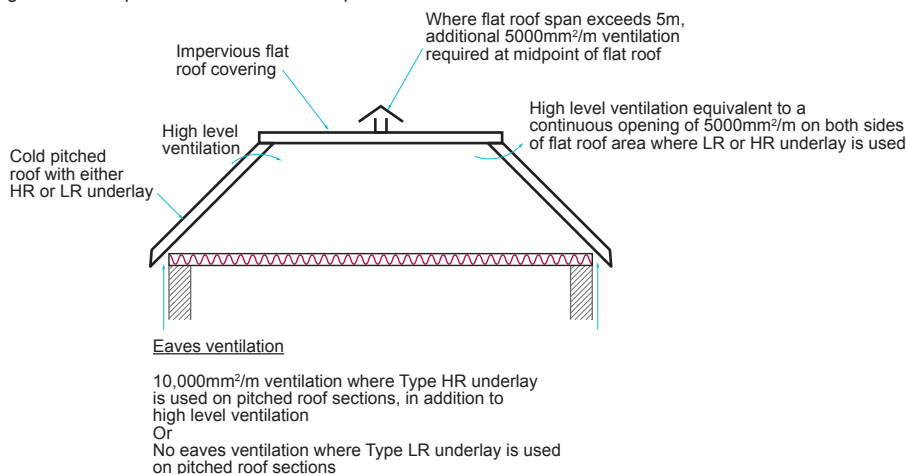

### Air impermeable outer weatherproof covering

This section provides guidance on the roof ventilation strategy where an air impermeable outer weatherproof covering is used.

Outer weatherproof coverings of fibre cement slates, sheet metal, continuous bitumen or plastic membranes, are typically considered to be air impermeable, manufacturers information should be consulted.

Roofs with a Type HR underlay and air impermeable outer roof covering, should be ventilated in accordance with the following guidance:

- cold roof - Table 11
- warm or hybrid roof - Table 12

Roofs with a Type LR underlay and air impermeable outer roof covering, should be ventilated in accordance with:

- cold roof - Table 15
- warm or hybrid roof - Table 16

**Table 15:** Cold roof ventilation (Type LR underlay and air impermeable outer roof covering)

Roof pitch	Ceiling type	Minimum eaves/low level ventilation (underneath underlay)	Minimum batten space ventilation using min. 25mm deep counterbattens (above underlay) <sup>(1)</sup>
10° to <75°	Normal <sup>(2)</sup>	7000mm <sup>2</sup> /m	25 000 mm <sup>2</sup> /m at eaves/low level and 5000 mm <sup>2</sup> /m at ridge/high level
10° to <75°	Well-sealed <sup>(2)</sup>	3000mm <sup>2</sup> /m (or 5000 mm <sup>2</sup> /m ridge or high level ventilation based on the longest horizontal dimension of roof)	25 000 mm <sup>2</sup> /m at eaves/low level and 5000 mm <sup>2</sup> /m at ridge/high level

Notes:

1. If no batten space ventilation is provided then the LR underlay should be treated as an HR underlay and ventilation provided in accordance with Table 11 above.
2. A normal ceiling typically has an air permeability of 300 mm<sup>2</sup>/m<sup>2</sup> (0.3%). A well-sealed ceiling conforms to BS 9250 and typically has an air permeability of not more than 30mm<sup>2</sup>/m<sup>2</sup> (≤0.03%).

Figure 53: Cold roof – Type LR underlay with air impermeable covering

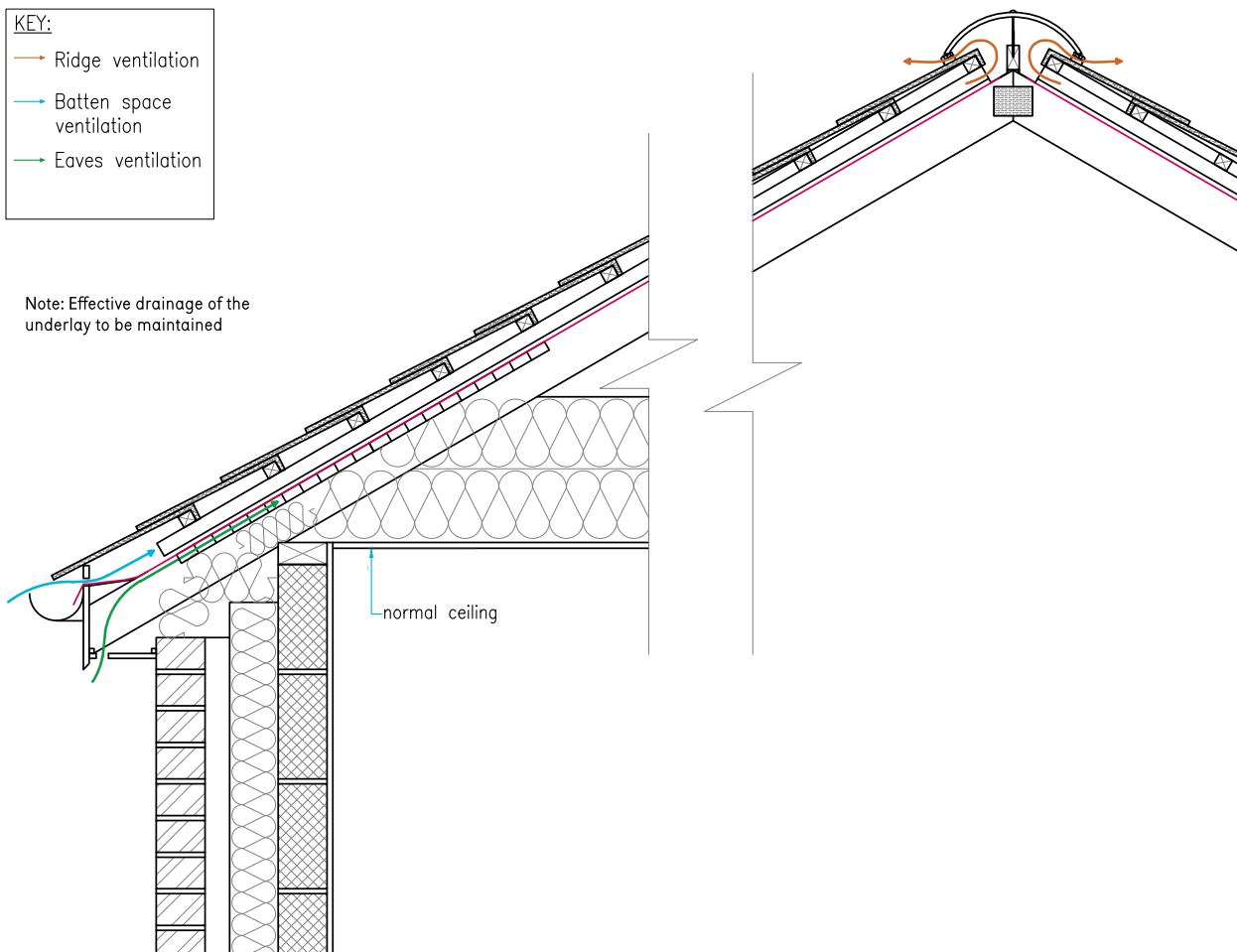

**Table 16:** Warm or hybrid roof ventilation (Type LR underlay and air impermeable outer roof covering)

Roof pitch and type	Minimum eaves/low level ventilation (underneath underlay)	Minimum ridge/high level ventilation (underneath underlay)	Minimum batten space ventilation using min. 25mm deep counterbattens (above underlay)	Minimum ridge/high level ventilation (above underlay)	Additional requirements
10° to <75° Warm roof	None	None	25 000mm <sup>2</sup> /m at eaves or low level	5000mm <sup>2</sup> /m	AVCL required Underlay drape should be maintained
10° to <75° Hybrid roof	7000mm <sup>2</sup> /m	5000mm <sup>2</sup> /m	25 000mm <sup>2</sup> /m at eaves or low level	5000mm <sup>2</sup> /m	AVCL required A minimum 25mm clear ventilation pathway <sup>(1)</sup>

Note:

1. Minimum 25mm clear ventilation pathway is measured from the lowest point of the underlay drape or underside of sarking.

Figure 54: Warm roof – LR underlay with air impermeable covering

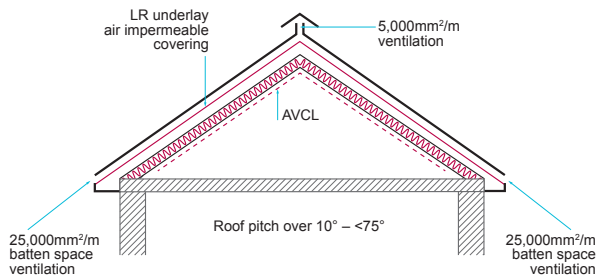
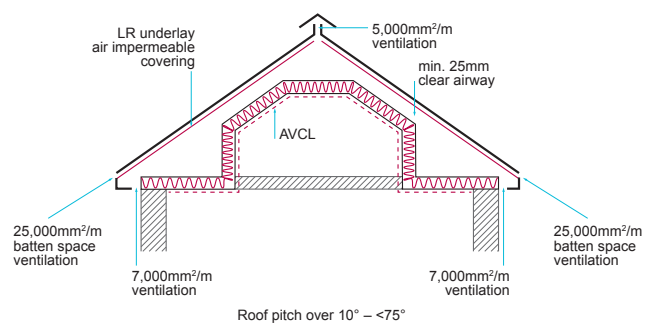

Figure 55: Hybrid roof - LR underlay with air impermeable covering



**Pitched roofs with no ventilation provision and air impermeable outer weatherproof covering**

Pitched roofs with no ventilation provision and air impermeable outer weatherproof covering will not be acceptable to NHBC.

## Vapour control

Air and vapour control layers (AVCL) should be provided in accordance with the design, and be:

- placed on the warm side of insulation
- used in warm and hybrid roof construction.

Figure 56: Ceiling penetrations

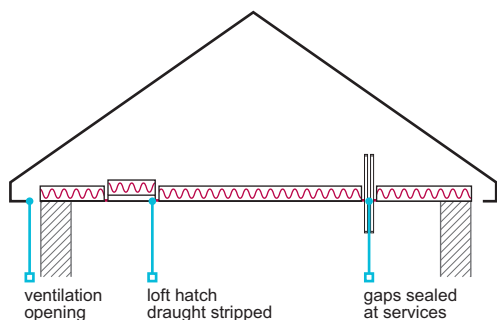

Air and vapour control layers should be:

- installed once framing timbers have a moisture content of less than 20%
- installed once the building is weathertight
- selected in accordance with the design eg a minimum 500 gauge (125 micron) polyethylene sheet, vapour control plasterboard or a product assessed in accordance with Technical Requirement R3
- fixed at 250mm centres to framing members including laps and around openings, boards should be fitted in accordance with Chapter 9.2 'Wall and ceiling finishes'
- lapped into openings ie, roof windows, dormers, etc
- sealed around service penetrations, where used downlighters should be specified and sealed to limit air leakage
- made good where damage has occurred.

Joints in the air and vapour control layers:

- should have 100mm minimum laps
- should be located on rafters
- may be sealed with adhesive tape for enhanced air tightness (but joints should still occur over rafters).

Where vapour control plasterboard is used, joints should be:

- positioned on rafters
- cut with care to avoid displacing the vapour control material
- filled, taped and finished, in accordance with the design and manufacturers recommendations.

Where the ceiling below a cold pitched roof includes an air and vapour control layer, the design should ensure adequate ventilation is provided to the habitable areas to prevent condensation problems in the home.

Access hatches to cold roof voids should have:

- an air leakage rate not more than  $1\text{m}^3/\text{h}$  at a pressure of 2 Pa when tested to BS EN 13141-1, or
- a push-up cover with a minimum weight of 5.5 kg and compress a closed cell seal or 'o-ring' between the cover and frame (clamps may also be required to ensure that the cover compresses the seal).

Proprietary hatches should be fitted and sealed to the surrounding construction in accordance with the manufacturer's instructions.

## Insulation

Insulation should be of sufficient thickness to meet the requirements of Building Regulations and laid over the whole loft and wall plate.

The thermal performance of any access hatch should contribute to the overall thermal performance of the ceiling or wall in which the hatch is located and avoid cold bridging.

**Table 17:** Suitable materials for roof insulation

Material	Standard
Mineral wool	BS EN 13162
Blown mineral fibre	BS 5803-2
Blown cellulose fibre	BS 5803-3
Rigid polyurethane foam	BS EN 13165
Proprietary products	Technical Requirement R3 <sup>(1)</sup>

Note:

- Proprietary products should hold a satisfactory assessment by an appropriate independent technical approval's authority acceptable to NHBC.

## Pipework

To reduce the risk of freezing or condensation forming on pipework in roof voids, the following precautions should be taken:

- where possible, water pipes should be below the main roof insulation
- water pipes should be insulated in accordance with Part 8 'Internal services and low or zero carbon technologies'
- roof insulation should be placed above and around water tanks, but not below them
- 'cold rising' pipework above ceiling level should be insulated, even where it is below the main roof insulation.

Figure 57: Storage tank insulation

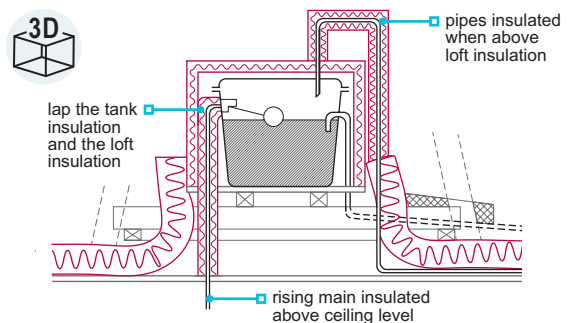

### 7.2.16 Fire-stopping and cavity barriers

Also see: Chapter 6.8

**Pitched roofs shall be constructed to provide adequate fire resistance and separation.**

Fire-stopping should be provided in accordance with the Building Regulations, including, at the junction between a compartment wall and roof and be extended into any eaves.

When providing fire-stopping:

- gaps between compartments should be fire-stopped, using materials which achieve the same level of fire resistance as the compartment wall
- compartment walls should stop approximately 25mm below the top of adjacent roof framing, and a soft fire-stopping material, should be used to allow for movement in roof timbers and prevent 'hogging' of the tiles.

Cavity barriers should be provided in accordance with the Building Regulations, including, at the edges and junctions of cavities.

When providing cavity barriers, they should be:

- sized appropriately for the cavity
- tightly fitted to a rigid construction
- mechanically fixed in position.

Combustible material, such as roof timbers and sarking felt, should be kept away from heat sources.

Figure 58: Fire precautions

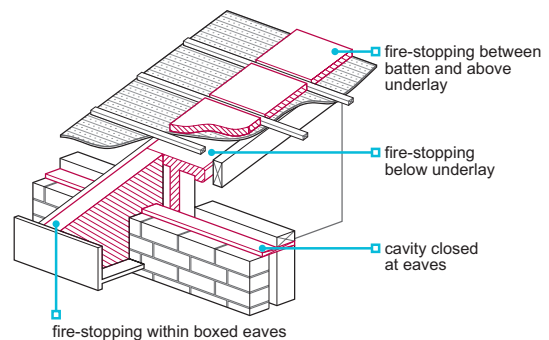

### 7.2.17 Battens

Also see: Chapter 3.3 and Part 8.0

**Battens and counter battens shall be adequately sized, spaced and fixed to support the roof covering.**

Battens and counter battens should be:

- in accordance with BS 5534, accompanied by a delivery note and indelibly marked with the supplier, origin, grade and size
- preservative treated and not re-sawn, ripped or planed after treatment (battens can be cut to length)
- where cut ends are located in wet or dry verges, treated with preservative
- cut square, butt jointed over rafters and nailed to each rafter they span
- fixed by skew driven nails on each side of a joint.

Counter battens should be fixed to the rafters and not only to sarking sheets or boards. The dimensions of counter battens should be sufficient to provide a ventilation gap (where required) and permit a drainage pathway beneath the battens.

Battens should be:

- a minimum of 1.2m long and span a minimum of three rafters
- set out in straight lines parallel to the ridge and to the gauge required for the tile or slate (the lap should not be decreased as this would reduce weathertightness)
- set out so that the tiles project a minimum of 50mm over the gutter
- fixed through counter battens to rafters
- where on sarking sheets or boards, be supported on counter battens
- at verges, tile battens should finish 25mm-50mm from the face of the protecting undercloak
- sized in accordance with the roof covering/solar roof panel manufacturer's recommendations, but not less than shown in Table 18.

**Table 18:** Minimum batten sizes

		450mm span		600mm span	
		Depth	Width	Depth	Width
Double lap slates	Natural: sized or random	25mm	50mm	25mm	50mm
	Fibre cement or concrete	25mm	38mm	25mm	50mm
Clay/concrete tiles	Double lap	25mm	38mm	25mm	38mm
	Single lap	25mm	38mm	25mm	50mm

Notes

- 1 Tolerances on the basic sizes of timber battens should be: width  $\pm 3$  mm, depth  $-0 +3$  mm.
- 2 Batten sizes may need to be increased, where solar roof panels are installed, to ensure full fixing depth penetration is achieved.

Battens should be set out to avoid joints occurring over the same rafter. Where batten spacing is:

- more than 200mm, no more than one batten in any group of four should be joined over any one truss or rafter, see Figure 60
- 200mm or less, no more than three joints should be made over any twelve consecutive battens, see Figure 61.

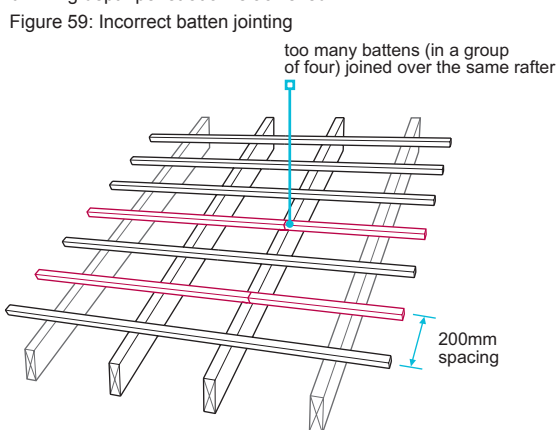

Figure 60: Correct batten jointing – batten gauge >200mm

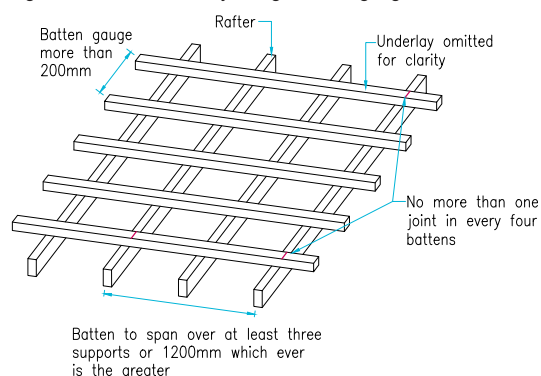
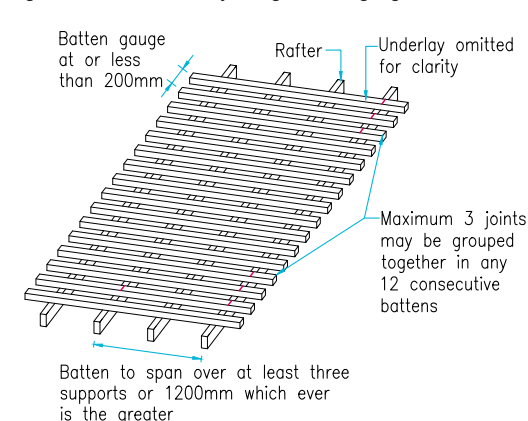

Figure 61: Correct batten jointing – batten gauge  $\leq 200$ mm



Batten fixings should be capable of resisting wind forces in accordance with BS 5534 (Annex H.7 'Batten fixing penetration'). The length, type and material specification of the fixing to be used, should be determined according to the site exposure and location.

Nails for fixing battens and counterbattens, should meet the following minimum requirements:

- be a driven nail of a minimum of 3.35mm diameter with 40mm minimum penetration into the supporting structure
- a mechanical gun nail with a shank diameter not less than 3.1mm
- round plain shank, indented, spiral roll or annular ring shank nails maybe selected (ring shank nails are recommended in Scotland and Northern Ireland)
- zinc-coated in accordance with BS EN 10230-1
- hot dip galvanised steel or aluminium when situated in a coastal location.

Nails should not be driven below the top of the batten, this reduces the thickness of timber between the nail head and the underside of the batten, which reduces the pull-off resistance and may damage the batten.

### 7.2.18 Roof coverings

Also see: Part 8.0

**Roof coverings shall be of a suitable quality and durability to protect the building from weather.**

When covering a pitched roof:

- coverings should be in accordance with the design and established building practices
- recovered materials may be used where prior approval by NHBC has been granted (independent certification of suitability may be required).

**Table 19:** Standards relevant to roof coverings

Material	Standard	Code of Practice	Other guidance
Clay tiles and fittings	BS EN 1304		
Concrete tiles and fittings	BS EN 490 and BS EN 491		
Dry fixed systems	BS 8612		
Natural slates	BS EN 12326		
Fibre cement slates and fittings	BS EN 492		
Fully supported lead sheet roofing		BS 6915	Technical requirement R3
Rolled lead sheet for building purposes	BS EN 12588		
Zinc and zinc alloys	BS EN 988	CP 143-5	Technical requirement R3
Copper	BS EN 1172	CP 143-12	Technical requirement R3
Stainless steel	BS EN 508-3		Technical requirement R3
Aluminium	BS EN 508-2	CP 143-15	Technical requirement R3
Roof windows	BS EN 14351-1		Technical requirement R3
Natural stone slates			Established practices
Thatch			Standards set by the Thatching Advisory Services or other appropriate authority, in accordance with Technical Requirement R3
Shingles should be of western red cedar			Grade 1 to the Canadian Standards Association
Proprietary roof coverings and products ie, Flashings, soakers, GRP and composite products (dormers, chimneys, copings, cappings, bay window canopies, etc)			Proprietary products should hold a satisfactory assessment by an appropriate independent technical approval's authority acceptable to NHBC.

Natural slates used for roofing should meet the requirements of Table 20.

**Table 20:** Acceptable characteristics for natural slates

Characteristics	Grade to BS EN 12326:2014 <sup>(1)</sup>
Water absorption less than 0.6%	W1
Thermal cycle	T1
Carbonate content less than 20%	S1

Note

1 A copy of the slate manufacturers Accompanying Commercial Document (ACD), in accordance with BS EN 12326:2014, should be provided to NHBC when requested.

### 7.2.19 Fixing tiles and slates

Also see: BS 5534

**Coverings shall be suitably fixed to protect the building from weather. Issues to be taken into account include:**

- |                               |                               |
|-------------------------------|-------------------------------|
| a) eaves, ridge and hip tiles | c) mortar                     |
| b) verges                     | d) mansard roofs and dormers. |

Careful setting out will improve the finished appearance of the roof, help avoid problems such as unequal overhangs, and reduce excessive tile cutting at abutments, chimneys and similar obstructions.

When installing coverings:

- clay tiles that do not meet the dimensional and geometric requirements given in BS EN 1304 should not be laid at pitches less than 40°
- joints between tiles and slates should be slightly open, which provides some flexibility in setting out and should help to avoid tile cutting (single lap interlocking tiles have a tolerance of approximately 3mm at the joint)
- double tiles, tile-and-a-half or half tiles can be used, when available from the manufacturer (to avoid the use of small sections of cut tiles). Alternatively, where the tile manufacturer provides guidance, small sections of single lap tile can be bonded to full tiles
- the bottom edges of double-lapped slate and plain tile roofs should be finished with an under-eaves course.

**Table 21:** Pitch, gauge and lap

Type or tile	Gauge	Minimum headlap	Minimum permissible pitch (°)
Plain (double lap)	Maximum 1/3 length lap	65mm generally for clay tiles 75mm in severe exposure conditions	35 (clay) 35 (plain concrete)
Concrete (single lap interlocking)	Comply with the manufacturer's recommendations	75mm or to the manufacturer's recommendations	30 <sup>(2)</sup>
Slates (double lap)	Maximum 1/3 length lap	54mm <sup>(1)</sup> minimum, increased with lower pitch and severe exposure conditions	20 subject to headlap

Notes

- For pitches greater than 45° and less than 75° in sheltered and moderate exposure zones only.
- For pitches below 30°, evidence shall be provided as to suitable performance.

When fixing coverings to a pitched roof:

- the fixing schedule should be produced by the tile manufacturer; fixings for single and double lap tiles should be in accordance with BS 5534 and BS EN 1994-1-4 (evidence of calculations in compliance with Technical Requirements R3 and R5 may be required)
- coverings should be fixed in accordance with the design and the manufacturer's recommendations
- perimeter (see definitions) roof tiles or slates should be mechanically fixed using a minimum of two fixings (subject to meeting the wind loading recommendations), one of which can be a tile clip, adhesive (following manufacturers recommendations) or dry verge capping system where designed to resist uplift
- slates and tiles should generally be fixed using clout or slate nails, these should be either silicon bronze, phosphor bronze, aluminium to BS 1202-3 or copper to BS 1202-2, additionally tiles can also be fixed using stainless steel clout nails
- galvanized steel nails should not be used for slates and tiles
- fixings should be a minimum of 38mm long, and penetrate a minimum of 15mm into battens
- tile clips should be made of aluminium alloy or other alloy types, stainless steel, non-ferrous metals or polymer based materials and be of adequate durability and strength in accordance with BS 5534
- slates should be fixed in accordance with BS 5534, fully nailed over the whole roof, and nailed twice where centre nailed. Alternatively slate hooks maybe used where they can be shown to resist wind uplift.

Where slate hooks are used they should:

- meet the requirements of BS 5534
- have a minimum shank diameter of 2.7mm
- be stainless steel grade 316 to BS EN 10088-3
- be 'nail-in' type slate hooks and not 'hook-over' batten type
- have a crimped shank when used on roof pitches less than 30 degrees. Slate hooks should not be used on roof pitches below 25 degrees.

Where the hooked fixing method is used, slates at the perimeters of a roof eg eaves, valleys, verges, ridges, hips, abutments and penetrations, should be nailed (or nailed and hooked) to resist uplift and lateral drift.

### Eaves, ridge and hip tiles

At eaves:

- tiles should project a minimum of 50mm across the gutter
- when using natural or fibre cement slates or plain tiles, an under-eaves course should be used
- the height of the fascia should maintain the tile pitch, in accordance with the tile manufacturer's recommendations.

Where ridge tiles are mortar bedded:

- on duo-pitched roofs the underlay should be lapped over the ridge in accordance with Table 10
- on mono-pitched roofs the underlay should extend over the mono ridge by a minimum 100mm
- small openings above the top batten are permitted at ridges where required for ventilation of the roof void.

At hips:

- underlay should continue to form a 150mm minimum lap parallel with the hip rafter
- where wet bedded tiles are used, they should be supported at the base by a galvanized hip iron and project to the centre line of the gutter.

Ridge and hip tiles should be mechanically fixed with self-sealing non-ferrous fixings into timber battens, and have a nominal joint thickness of 10mm where wet bedded.

Figure 62: Eaves detailing

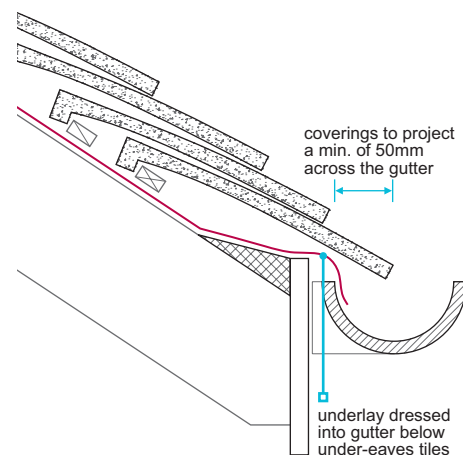
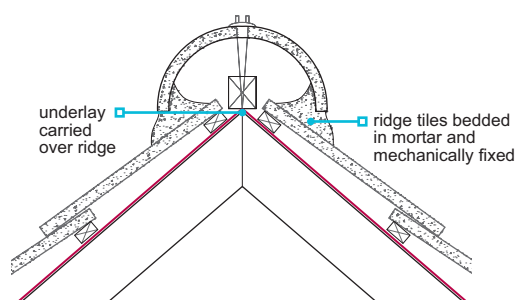

Figure 63: Mechanically fixed ridge



Wet bedded 'baby' hip/ridge tiles to low level roofs, such as those over porches and ground floor bay windows, may be bedded using mortar only, subject to self-weight being sufficient to resist the wind loads, in accordance with BS 5534 (Annex H). Where no wind uplift calculation is provided, baby hip/ridge tiles should be mechanically fixed, in accordance with manufacturer's recommendations.

Where proprietary dry fixed, ridge and hip systems are used, they should conform to BS 8612 and be installed in accordance with manufacturers requirements.

Figure 64: Wet bedded ridge with dentil tiles

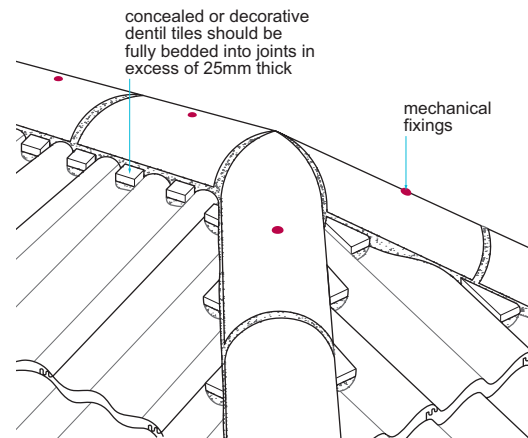

### Verges

Where proprietary dry verge systems are used, they should conform to BS 8612 and be installed in accordance with manufacturers requirements.

Unless a proprietary dry verge system or cloaked verge is used, tiles should be bedded into a 100mm wide bed of mortar on an undercloak of fibre-cement board, plain tile or slate. Undercloaks should be a minimum 150mm wide and laid face down. Plain tiles should not be used as an undercloak below 30° pitch or on a bargeboard.

Undercloak should be:

- fixed in accordance with manufacturer's recommendations
- installed to a true line
- installed at the correct level to ensure that the line of the tiling is maintained where it passes over the wall, and not tilt inwards
- bedded on roofing mortar and struck off flush with the external surface of the wall (alternatively, a suitable exterior grade bedding sealant should be used in accordance with the manufacturer's recommendations)
- securely nailed to a true line where a bargeboard is used.

Figure 65: Wet verge

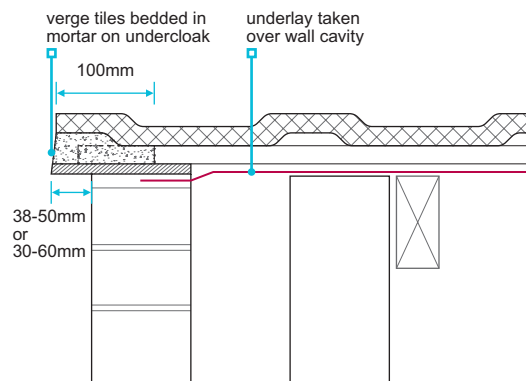
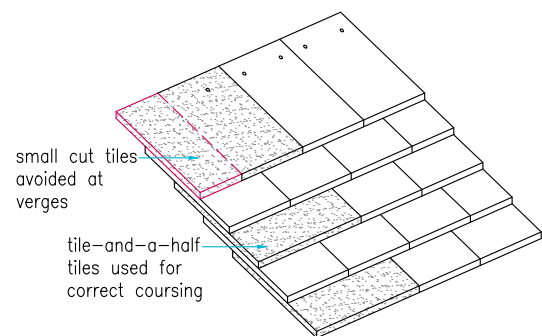

Figure 66: Verge - plain tiles



Where verge tiles and slates are wet bedded, pointing should be completed as soon as possible using the same mix.

Verge clips should be in full contact with the tile to resist uplift, nailed twice to battens and sized to ensure that they are in direct contact with the top surface of the verge tile.

Where plain tiles and slates are used at the verge:

- they should project 38-50mm beyond the gable wall or bargeboard
- cut plain tiles are not acceptable, and purpose-made plain tile-and-a-half tiles should be used, see Figure 66
- natural slate verges should be formed with full slates and either slate-and-a-half or half slates that are a minimum of 150mm wide.
- small sections (less than a half tile width) of cut interlocking tiles should be avoided. Where cut tiles (less than half a tile width) are used, these should be bonded to the adjacent tile in accordance with manufacturers recommendations.

Where interlocking tiles are used at the verge:

- they should project 30-60mm beyond the gable wall or bargeboard

## Mortar

When bedding tiles or slates in mortar:

- the mortar should be 1:3 cement: sand with plasticiser
- the mortar should be a mix based on sharp sand with soft sand added to achieve workability; the proportion of sharp sand should not be less than one third of the total sand content (proprietary mixes may be accepted by NHBC where they are shown to have similar strength, durability and workability)
- pointing should be completed as soon as possible using the same mix
- tiles should be wetted on their contact surface, and surface water allowed to drain away before fixing
- concealed or decorative dentil tiles should be fully bedded into joints in excess of 25mm thick.

## Tiling and slating of mansard roofs and dormers

When fixing tiling and slating to mansard roofs (75° or steeper) and dormers:

- all tiles and slates should be fixed in accordance with manufacturers requirements and BS 5534
- tiles and slates should be fully nailed; single lap tiles require additional tail clips, double lap tiles (nibbed) require two nails, fibre cement slates require additional disc rivets, slates should be centre nailed
- all tiling and slating should be laid over battens and counter battens, secured to the sheathing board in line with vertical supports
- batten and counter batten sizes should be in accordance with this chapter
- a suitable breather membrane/underlay should be provided in accordance with BS 5534
- the length of the top course should ensure that the minimum headlap is maintained
- the bottom edges (eave) should be finished with an under-course tile or slate, which extends a minimum 50mm below the tilting fillet
- the eave course should be supported by a tilting fillet or other proprietary product which substantially maintains the same plane as the main cladding
- at internal or external angles, purpose-made corner tiles or soakers should be used to form weathertight joints
- where pitched roofs abut a dormer, abutments should be formed in accordance with Clause 7.2.20 and BS 5534
- at dormer cheeks, the tiles or slates should be specified to be cut close to the slope of the roof
- where air impermeable outer weatherproof coverings eg fibre cement slates are used, ventilation behind the weatherproof covering should be in accordance with manufacturers requirements.

Vertical tiling and slating to walls should conform to Chapter 6.9 'Curtain walling and cladding'.

## 7.2.20 Weathering details

Also see: Chapter 6.8

Weatherproofing shall be provided at abutments, flat roof intersections, changes in slopes and projections to resist the passage of moisture to the inside of the building. Issues to be taken into account include:

- |   |                                 |
|---|---------------------------------|
| a) abutments                                  | c) projections through the roof |
| b) flat roof intersection or changes in slope | d) raking copings.              |

Flashing details should be appropriate for the roof and the type of roof covering used, in accordance with BS 5534. Where flashings come into contact with metal, they should be formed using non-ferrous material.

**Table 22:** Suitable materials for flashings

Material	Standard	Additional information
Rolled lead sheet <sup>(2)</sup>	BS EN 12588	Apron and cover flashings <sup>(1)</sup> , saddles <sup>(1)</sup> and soakers should: <ul style="list-style-type: none"> <li>• be a minimum Code 4 (blue) and soakers minimum Code 3 (green)</li> <li>• not exceed 1.5m in length</li> </ul>
Aluminium and aluminium alloys	BS EN 485 and BS EN 573	0.7 - 0.9 mm thick and protected on both sides by a coating of bituminous paint where built into brick, stone or concrete
Zinc alloy	BS EN 998	Minimum of 0.8 mm thick
Copper	BS EN 1172	Flashings, soakers and saddles should be: <ul style="list-style-type: none"> <li>• fully annealed</li> <li>• 0.55mm thick (0.7 mm thick for inclined valleys)</li> </ul>
Proprietary products eg lead replacement products, GRP flashings etc	Technical Requirement R3 <sup>(3)</sup>	

Notes:

1. Lead thickness may need to increase in line with the severity of exposure. Thicknesses quoted are for sheltered to moderate exposure zones.
2. Where lead flashings are turned into joints by more than 50mm, they will require bitumen paint protection on both sides.
3. Propriety products should hold a satisfactory assessment by an appropriate independent technical approval's authority acceptable to NHBC.

## Abutments

Where a flat or pitched roof over an enclosed area abuts a wall, or a balcony abuts a wall, cavity trays should be linked to the flashing to prevent water penetrating into an enclosed area. Horizontal flashings should provide weathering to a minimum of 75mm above the intersection with the roof.

At abutments:

- flashings, soakers and gutters should be provided as necessary
- lead flashings should have a minimum upstand of 75mm and minimum lap of 100mm
- flashings should be tucked 25mm into a bed joint and wedged in place at not more than 450mm centres, or a minimum of one per step for stepped flashings
- joints between the masonry and flashing should be pointed with cement mortar or suitable exterior grade sealant in accordance with the manufacturer's recommendations
- free edges of lead flashings should be clipped to prevent lifting, in accordance with the Lead Sheet Training Academy 'The complete manual'.

Where a pitched roof abuts the wall at an angle:

- a preformed stepped cavity tray linked to a stepped flashing should be used
- stepped flashings should be cut from a strip a minimum of 150mm wide
- stepped flashings should be a minimum of 65mm wide.

Figure 67: Wall abutment

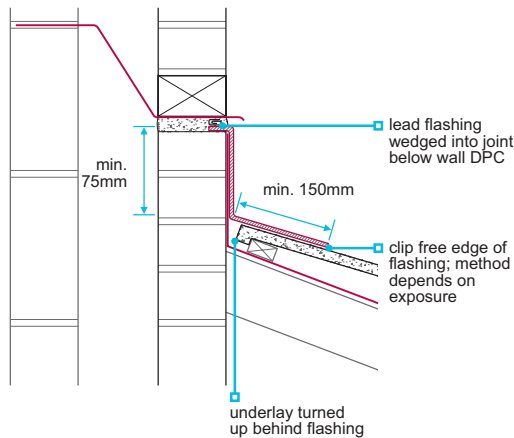
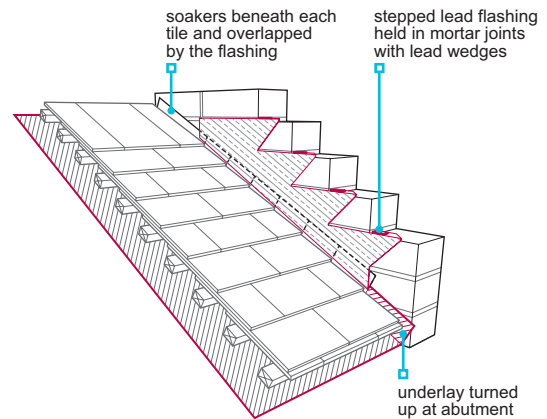

Figure 68: Side abutment (double lap clay or concrete plain tile and slate)



Roof side abutment details should be correctly formed, dependent upon the chosen tile or slate.

When using double-lap clay and concrete plain tiles, side abutments should be formed:

- using soakers and step flashings or
- an abutment gutter including a single step flashing, detailed in accordance with manufacturers recommendations (where there is a risk of blockage by debris, a step and cover flashing should be provided).

When using single-lap clay and concrete interlocking tiles, side abutments should be formed:

- for profiled tiles, a flashing detail conforming to the tile manufacturer's recommendations or an abutment gutter including a single step flashing, detailed in accordance with manufacturers recommendations (where there is a risk of blockage by debris, a step and cover flashing should be provided)
- for flat or substantially flat tiles, an abutment gutter including a single step flashing, detailed in accordance with manufacturers recommendations (where there is a risk of blockage by debris, a step and cover flashing should be provided).

When using natural or artificial slates, side abutments should be formed:

- using soakers and step flashings or
- an abutment gutter including single step flashing, detailed in accordance with manufacturers recommendations (where there is a risk of blockage by debris, a step and cover flashing should be provided).

Figure 69: Side abutment gutter

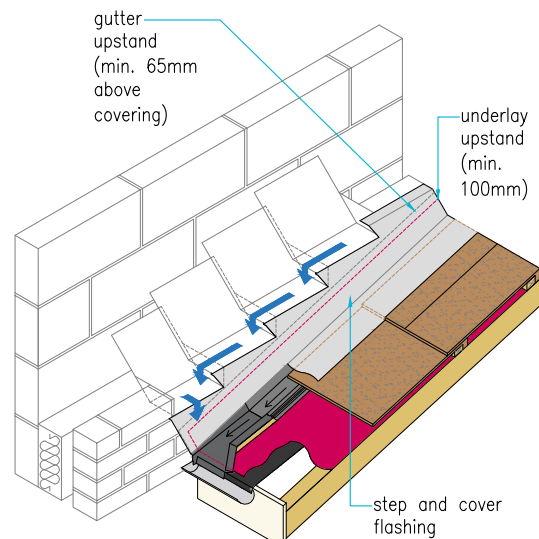

Where abutment gutters are constructed using sheet metal they should be detailed in accordance with the relevant sheet metal technical recommendations.

### Flat roof intersection or changes in slope

Where there is a change in the slope, or an intersection with a flat roof and:

- the change is  $5^\circ$  or more (eg at mansards and sprockets), flashings or soakers should be used
- a saddle flashing should be used where a ridge meets the main roof.

Where a flat roof adjoins a pitched roof:

- the waterproof membrane should be carried up under the tiling to a height of 150mm above the flat roof, and lapped by the roofing underlay
- the lowest course of tiles or slates should not touch the roof membrane.

Figure 70: Dry valley - lead saddle

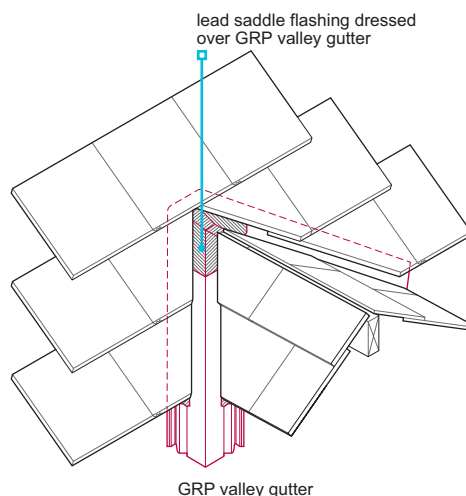
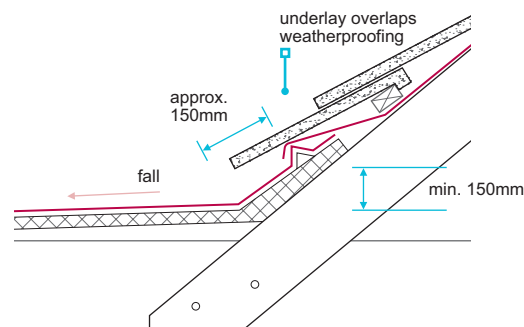

Figure 71: Flat roof adjoining a pitched roof



### Projections through the roof

Where there is a projection through the roof:

- components should be installed according to the manufacturer's recommendations
- flashings should be provided (eg at chimneys)

- where pipes penetrate tiling, a weathertight joint should be formed using a lead slate flashing and upstand or a purpose-made one-piece accessory. Where lead slates are used they should be supported (eg using exterior grade plywood) to prevent sagging.

Figure 72: Chimney - back gutter

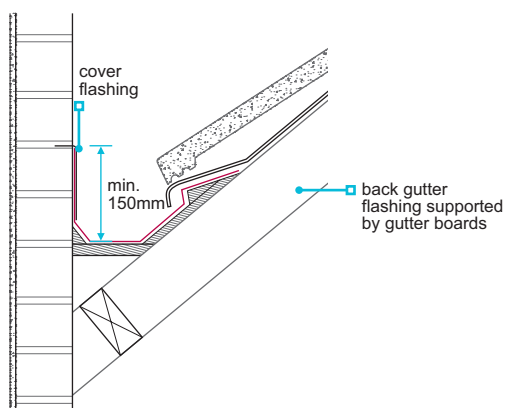
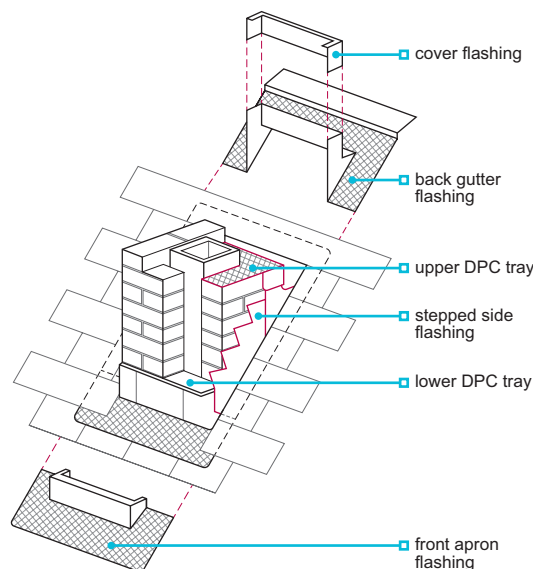

Figure 73: Chimney penetration



## Raking copings

Copings, including those manufactured from natural stone, reconstituted stone and GRP, should be securely fixed to gable walls using suitably durable fixings, and be weathertight.

To resist wind uplift and gravitational forces, L-shaped brackets should be used to secure each stone coping to the head of the wall.

The brackets should:

- have dowel bars that fit into restraint holes in the copings
- be adequately durable and manufactured from stainless steel (such as grade 304/316 to BS EN 10088-2)
- be fixed to a solid piece of masonry, with fixings of a suitable length, gauge and durability.

DPCs should prevent the downward passage of moisture and be installed under the coping to ensure that the wall is weathertight. The DPC should:

- be bitumen-based material to BS 6398, BS EN 14967 or other material assessed in accordance with Technical Requirement R3
- extend the full width of the wall
- be fully bedded in mortar
- be supported over the cavity.

Fixing methods that penetrate the DPC should be designed to ensure weathertightness. This can be achieved by extending the lower DPC under the bracket, and installing the next section of the DPC over it to create a lap that covers the fixing point.

Copings should have an overhang with throatings a minimum of 30mm clear of the wall, 40mm where the wall is rendered.

Figure 74: Raking coping - masonry

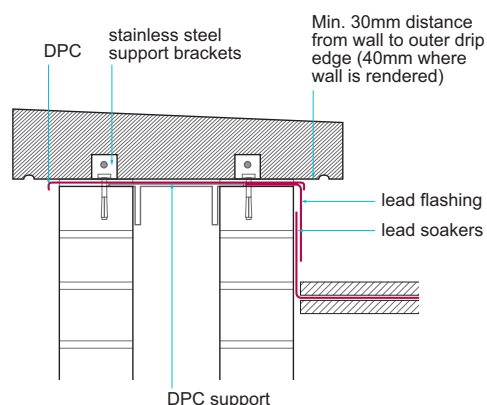
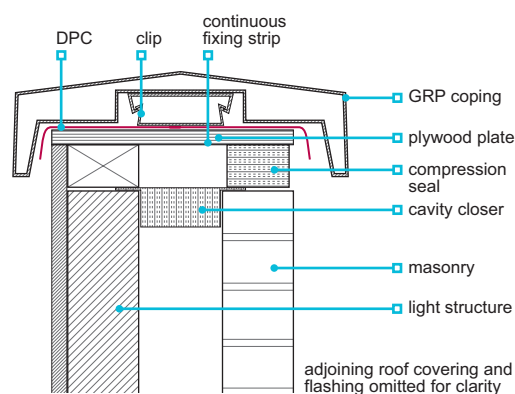

Figure 75: Raking coping - framed structure



Where GRP copings are used, they should:

- be fixed in accordance with the manufacturer's instructions
- include a DPC beneath
- be sealed using an appropriate sealant
- allow for normal differential movement in the timber or LSF structure
- hold a satisfactory assessment from an appropriate independent technical approvals authority acceptable to NHBC.

Further guidance can be found in Chapter 6.2 'External timber framed walls' and Chapter 6.10 'Light steel framing'.

**7.2.21 Valleys and hidden gutters**

**Valleys shall have suitable weathering details, including flashings, to resist the passage of moisture to the inside of the building.**

Valleys, and the components used, should:

- be in accordance with the design and BS 5534
- have a finished pitch which complies with the minimum recommended for the roof
- be fixed in accordance with the manufacturer's recommendations
- have a suitable saddle flashing (see Figure 70) or appropriately detailed lead flashing (minimum code 4) at the head of each valley
- be formed using: valley coursing tiles (plain tiles), valley trough tiles (interlocking tiles), non-ferrous metal or proprietary products which hold a satisfactory assessment from an appropriate independent technical approvals authority acceptable to NHBC.

Tiles either side of an open valley should:

- be cut from double tiles, tile-and-a-half or half tiles where available from the manufacturer
- where small pieces (less than half tile width) of cut single lap tiles are used, these should be bonded to the adjoining full width tile, in accordance with manufacturers recommendations.

Where the roof covering is slate or plain tiles, the following may be used:

- a laced valley
- a swept valley
- a mitred valley with soakers.

Horizontal valley gutters, where positioned over a compartment wall, should achieve the roof classification as required by the Building Regulations ie, B<sub>ROOF</sub>(t4) and be appropriately fire-stopped.

**Valleys using valley tiles**

Where valleys are formed using valley tiles:

- purpose-made valley coursing tiles should be used where the roof uses plain tiles
- purpose-made valley trough tiles should be supported by gutter boards where the roof uses single lap interlocking tiles
- they should be mechanically cut to the correct rake
- adjacent coverings should be neatly cut to form a smooth junction, and preferably be cut from tile-and-a-half tiles
- have a minimum 100mm wide channel (minimum 125mm for pitches below 30°)
- they should be fixed in accordance with manufacturers recommendations.

**Lead-lined valleys**

For lead-lined valleys, the tiles should be cut and bedded on mortar over an undercloak (to prevent direct contact between the lead and the mortar). Mortar should not bridge the welt detail.

Lead should be:

- either code 4 (blue) or code 5 (red)
- supported on gutter boards of a minimum 19mm exterior grade plywood to BS EN 636-3, or as specified in the design
- laid in strips no longer than 1.5m
- lapped by a minimum of 150mm, where pitches are above 30°
- used in accordance with the Lead Sheet Training Academy 'The complete manual'.

**Proprietary valley or gutter systems**

Proprietary valley systems should:

- be used in accordance with manufacturers recommendations and securely fixed to suitable supports (exterior grade materials should be used)
- be assessed in accordance with Technical Requirement R3.

Proprietary gutter systems should:

- be used in accordance with manufacturers recommendations and securely fixed to suitable supports (exterior grade materials should be used)
- be assessed in accordance with Technical Requirement R3.

### 7.2.22 Drainage

**Roof drainage shall adequately carry rainwater to a suitable outlet.**

Drainage should be:

- provided where roofs are greater than 6m<sup>2</sup>; however, consideration should be given to providing drainage to smaller roofs such as dormer, porch roofs and balconies (see Clause 7.1.4)
- of a sufficient size to accommodate normal rainfall, and sized to cope with concentrated flows, ie, where there are dormer roofs
- designed and fitted to prevent erosion of the lower surface, where water from a large roof surface discharges onto another surface
- fixed in accordance with the design, using the correct type of fittings for internal and external angles, outlets etc to ensure efficient drainage of the roof
- supported and jointed in accordance with the manufacturer's recommendations
- insulated when passing through a home, in accordance with Part 8.0 'Internal services and low or zero carbon technologies'
- installed ensuring gutters are provided with stop ends, and are laid with a sufficient fall towards the outlet, unless designed to be flat.

The discharge of rainwater in gutters and pipes from one roof to another should be avoided, where practicable. Small quantities of rainwater discharge, from one roof to another, are acceptable, if the total quantity discharged does not exceed the normal drainage characteristics of the roof below.

Where gutters are behind parapet walls, an overflow should be provided:

- sized for effective flow rate and positioned to prevent water from entering the building
- of higher capacity than the combined capacity of the other outlets
- positioned to discharge safely away from the building
- be visible when in operation.

Where a downpipe discharges above ground level, or above a drainage gully, the downpipe should be fitted with shoes.

### 7.2.23 Fascias and trim

Also see: Chapter 3.3

**Fascias, bargeboards and soffits shall be appropriately fixed and treated against decay.**

**Table 23:** Materials acceptable for fascia boards

Material	Standard	Minimum material specification	Additional information
Marine grade plywood	BS 1088	Standard grade	Coated
Exterior grade plywood	BS EN 636	Bond class 3	Preservative treated and coated
Natural solid timber boards	N/A	Timber should be preservative treated or naturally durable	See Table 1 in Chapter 3.3
High density fibre reinforced calcium silicate board	BS EN 12467	Category A	
Glass fibre reinforced cement (GRC) board			
Proprietary products	Technical Requirement R3		

When installing fascia boards and soffits:

- timber for external feature work should be free from waney edges, large knots, resinous pockets, splits and other unsightly defects
- where preservative treated timber is cut, preservative should be applied to the cut end
- where timber is to be painted, it should be knotted and primed on all surfaces before fixing
- where timber requires a stained finish, one coat of stain should be applied before fixing
- each joint should be cut and fixed neatly.

Fascia boards should be fixed:

- twice to each rafter
- with splayed butt joints.

### 7.2.24 Spandrel panels in cold roofs

#### Spandrel panels shall provide satisfactory performance.

Spandrel panels used in cold roof voids to create separation between dwellings or to form the inner leaf of gable walls should be designed, manufactured and installed to provide satisfactory performance. Items to be taken into account include:

- fire resistance
- acoustic transfer
- structural stability.

Spandrel panels that comply with guidance from the Structural Timber Association or the Trussed Rafter Association will generally be acceptable to NHBC.

### 7.2.25 Roof cassette systems

*Also see: Chapter 3.3*

#### Roof cassette systems shall form the roof structure and habitable space beneath and safely transmit loads to the supporting structure without undue movement or deformation. Issues to be taken into account include:

- |                                     |                                 |
|-------------------------------------|---------------------------------|
| a) provision of information         | e) condensation and ventilation |
| b) structural performance           | f) moisture protection          |
| c) thermal and acoustic performance | g) durability                   |
| d) fire                             | h) installation.                |

Roof cassette systems are building systems consisting of prefabricated roof panels which may also be supplied with prefabricated wall panels, beams and other supporting structure. Systems can be open or closed panel.

#### Provision of information

Clear and fully detailed drawings should be available on site to enable work to be carried out in accordance with the design. Design and specification information should be issued to site supervisors, relevant specialist subcontractors and other appropriate personnel, and include the following:

- a full set of drawings
- material specifications
- fixing schedules
- junction details eg steps and staggers in both the horizontal and vertical plane
- the position and material specification for cavity barriers and fire-stopping
- manufacturer's requirements relating to ancillary items eg chimneys, dormers, etc
- site installation manual.

#### Structural performance

The structure of the roof cassette system should be adequately designed to support dead, imposed and wind loads in accordance with the requirements of Clause 7.2.3.

Compound deflection of the roof cassette system should be designed to acceptable limits, particularly where they are supported by roof purlins.

#### Thermal and acoustic performance

The roof and walls of roof cassette systems, shall be insulated in accordance with the Building Regulations.

The roof and walls to roof cassette systems, shall be constructed to ensure that sound transmission is adequately limited between homes, in accordance with the Building Regulations.

#### Fire

The roof cassette system should meet the fire performance requirements of the Building Regulations, including all critical junctions eg where walls and roof cassettes intersect.

The roof cassette system should:

- have adequate structural fire protection
- provide adequate compartmentation between dwellings
- have cavity barriers and fire-stopping in accordance with the Building Regulations.

## Condensation and ventilation

The elements of the roof cassette system shall adequately limit the risk of interstitial condensation and be constructed in accordance with BS 5250. Air and vapour control layers should be provided in accordance with the manufacturer's recommendations.

Rooms formed by the roof cassette system shall be adequately ventilated in accordance with the Building Regulations.

## Moisture protection

Walls and roofs should be adequately protected from moisture, using appropriate breather membranes and roofing underlays.

Wall and roof membranes shall form a continuous barrier to moisture and be adequately lapped.

Roof coverings should be in accordance with this Chapter.

Wall cladding should be in accordance with the relevant NHBC Chapter(s).

## Durability

The structure of the system shall have a life expectancy of at least 60 years. Timber members should be preservative treated or have adequate natural durability in accordance with Chapter 3.3 'Timber Preservation (natural solid timber)'.

## Installation

The system shall be erected in accordance with the manufacturer's recommendations and provide satisfactory performance. Issues to be taken into account include:

- competence of installers
- preparation
- design tolerances
- structural connections
- sealing of joints.

The manufacturer should provide and make available on site a set of clear instructions in the form of a site installation manual and relevant accompanying drawings, detailing the assembly and installation for the system as appropriate.

Systems should be installed by operatives who:

- are competent
- are familiar with the system being installed and
- hold a certificate (or similar confirmation) confirming that they have been trained by the system manufacturer.

## Ancillary components

Ancillary components ie, dormers, chimneys, roof windows, should be capable of integrating with the roof cassette system to ensure structural integrity and weathertightness is maintained.

### 7.2.26 Solar roof panels

Also see: Part 8.0

**Solar roof panels should be securely fixed and not adversely affect the weather resistance of the building. Where the solar roof panels form the roof covering, they should be of suitable quality and durability to protect the building from weather. Issues to be taken into account include:**

- a) weather tightness
- b) fixing
- c) ventilation and vapour control
- d) durability.

## Weathertightness

Integrated solar roof panels should meet the weathertightness criteria in Part 8.0 'Internal services and low or zero carbon technologies'.

The installer should consult the tile or slate manufacturer prior to installing solar roof panels, to ensure compatibility with the tile or slate and weathertightness.

Connections may need to penetrate through the outer weatherproofing layer, which may potentially affect the roof covering, underlay and insulation of a roof. All penetrations should be carefully detailed, and appropriate flashings, etc used in accordance with the manufacturers recommendations, to ensure the weathertightness of the penetration.

Mounting brackets which pass through the tiling or slating should not affect:

- the weathertightness of the tiles or slates
- the stability of the tiles or slates.

Proprietary flashing kits should be used around integrated solar roof panels. Flashing kits should ensure the weathertightness of the array and be installed to avoid excess gapping, sagging or kicking of the tiles or slates and be fixed in accordance with manufacturer recommendations.

## Fixing

---

Where solar roof panels are installed to the roof, these may be either:

- the 'on-roof' type and sit above the roof covering or
- integrated into the tile or slate array, to also form the roof covering.

Solar roof panels may be secured:

- to the roof framing or
- to both the roof framing and roofing battens.
- to roofing battens or

Solar roof panels should be secured in accordance with manufacturers requirements and be capable of resisting wind uplift and snow loads for the building and its specific location, see also Part 8 'Services'.

Roofing battens, should be adequately fixed where used to secure solar roof panels. Batten fixings should be capable of resisting wind forces in accordance with BS 5534 (Annex H.7 'Batten fixing penetration'), see also Clause 7.2.17.

## Ventilation and vapour control

---

Where arrays of integrated solar roof panels are installed, forming the roof covering, then the roof covering should be treated as air impermeable and the whole roof ventilated accordingly, unless the panel manufacturer is able to demonstrate their system is air permeable, guidance on roof ventilation strategies can be found in Clause 7.2.15 of this chapter.

Solar roof panel manufacturers may also require a ventilated air space beneath the panel, to increase ventilation and cooling of the panel.

## Durability

---

Solar roof panels and associated brackets, fixings, flashings and trims should be adequately durable and suitable for their location.

Appropriate materials should be selected for flashings, guidance can be found in Clause 7.2.20 of this Chapter.

In aggressive environments such as coastal locations, grade 316 stainless steel fixings are recommended.

Figure reference table

Figure reference table 7.2			
Fig No	Title/Description	Clause	Page
Figure 1	Trussed trimmed rafters	7.2.3	3
Figure 2	Traditional roof members	7.2.3	4
Figure 3	Pole plate	7.2.3	4
Figure 4	Types of rafter	7.2.3	4
Figure 5	Permissible truss projection	7.2.6	6
Figure 6	Rafter to ceiling joist connection	7.2.7	7
Figure 7	Rafter to purlin connection	7.2.7	7
Figure 8	Purlin connection	7.2.7	7
Figure 9	Scarf joint	7.2.7	7
Figure 10	Angle tie	7.2.7	7
Figure 11	Dragon tie	7.2.7	7
Figure 12	Dragon tie (alternative)	7.2.7	7
Figure 13	Diminishing truss supported by continuous binders	7.2.7	8
Figure 14	Diminishing truss supported on long battens	7.2.7	8
Figure 15	Lateral restraint strap secured to timber blocking	7.2.8	8
Figure 16	Lateral restraint strap secured to longitudinal bracing	7.2.8	8
Figure 17	Restraint by gable ladder – masonry	7.2.8	9
Figure 18	Roof bracing – lap joint	7.2.9	10
Figure 19	Roof bracing – wall plate connection	7.2.9	11
Figure 20	Diagonal rafter bracing – square roofs	7.2.9	11
Figure 21	Diagonal rafter bracing – larger roofs	7.2.9	11
Figure 22	Diagonal rafter bracing – narrow fronted roofs	7.2.9	11
Figure 23	Intersection detail	7.2.9	12
Figure 24	Longitudinal bracing – ridge node	7.2.9	12
Figure 25	Longitudinal bracing – rafter node	7.2.9	12
Figure 26	Longitudinal binders – ceiling node	7.2.9	12
Figure 27	Chevron bracing – duo pitched roof	7.2.9	12
Figure 28	Mono-pitch truss - diagonal rafter bracing	7.2.9	13
Figure 29	Mono-pitch truss - diagonal bracing to end vertical member	7.2.9	13
Figure 30	Mono-pitch truss – longitudinal bracing	7.2.9	13
Figure 31	Mono-pitch truss - chevron bracing	7.2.9	13
Figure 32	Attic truss - diagonal bracing	7.2.9	14
Figure 33	Attic truss – diaphragm bracing	7.2.9	14
Figure 34	Attic truss – diaphragm bracing	7.2.9	14
Figure 35	Attic truss – diaphragm bracing	7.2.9	14
Figure 36	Attic truss – longitudinal bracing	7.2.9	14
Figure 37	Dormer – rafter supported	7.2.13	16
Figure 38	Dormer – floor supported	7.2.13	16
Figure 39	Ventilation to dormer pitched roofs	7.2.13	17
Figure 40	Room in roof (flat roof dormer)	7.2.13	17
Figure 41	Underlay detailing	7.2.14	19
Figure 42	Typical eaves ventilation	7.2.15	20
Figure 43	Roof pitch 10° to 15°	7.2.15	21
Figure 44	Roof pitch >15° and <75°	7.2.15	21
Figure 45	Mono-pitched roof	7.2.15	21
Figure 46	Hybrid roof - Room-in-roof	7.2.15	22
Figure 47	Hybrid roof - Room in roof (flat roof dormer)	7.2.15	22

Figure 48	Warm roof	7.2.15	22
Figure 49	Cold roof – LR underlay with air permeable covering	7.2.15	23
Figure 50	Warm roof - LR underlay with air permeable covering	7.2.15	24
Figure 51	Hybrid roof - LR underlay with air permeable covering	7.2.15	24
Figure 52	Cold pitched roof with flat roof apex	7.2.15	24
Figure 53	Cold roof – Type LR underlay with air impermeable covering	7.2.15	25
Figure 54	Warm roof – LR underlay with air impermeable covering	7.2.15	26
Figure 55	Hybrid roof - LR underlay with air impermeable covering	7.2.15	26
Figure 56	Ceiling penetrations	7.2.15	27
Figure 57	Storage tank insulation	7.2.15	28
Figure 58	Fire precautions	7.2.16	28
Figure 59	Incorrect batten jointing	7.2.17	29
Figure 60	Correct batten jointing – batten gauge >200mm	7.2.17	29
Figure 61	Correct batten jointing – batten gauge ≤200mm	7.2.17	29
Figure 62	Eaves detailing	7.2.19	32
Figure 63	Mechanically fixed ridge	7.2.19	32
Figure 64	Wet bedded ridge with dentil tiles	7.2.19	33
Figure 65	Wet verge	7.2.19	33
Figure 66	Verge - plain tiles	7.2.19	33
Figure 67	Wall abutment	7.2.20	36
Figure 68	Side abutment (double lap clay or concrete plain tile and slate)	7.2.20	36
Figure 69	Side abutment gutter	7.2.20	36
Figure 70	Dry valley - lead saddle	7.2.20	37
Figure 71	Flat roof adjoining a pitched roof	7.2.20	37
Figure 72	Chimney - back gutter	7.2.20	37
Figure 73	Chimney penetration	7.2.20	37
Figure 74	Raking coping - masonry	7.2.20	38
Figure 75	Raking coping - framed structure	7.2.20	38



## Technical Disclaimer

The NHBC Standards are produced by NHBC as guidance solely for our builder customers as to how to interpret the technical requirements in relation to the warranty cover provided by NHBC under its Buildmark, Buildmark Choice, Buildmark Link, Buildmark Solo, Buildmark Connect or any similar product from time to time. It has not been created or intended for distribution or use outside of that purpose. The information contained in the NHBC Standards do not constitute advice and is not to be relied upon by any third party. Nothing in the NHBC Standards is intended to, nor should it be taken to, create any legal or contractual relationship. Any third party who chooses to rely upon the information contained in the NHBC Standards shall do so entirely at their own risk and NHBC accepts no duty of care or liability, however caused, in connection with its use or reliance by any third party.



# Standards

# 2024

**NHBC, NHBC House, Davy Avenue, Knowlhill, Milton Keynes, Bucks MK5 8FP**

National House-Building Council (NHBC) is authorised by the Prudential Regulation Authority and regulated by the Financial Conduct Authority and the Prudential Regulation Authority in respect of carrying on its insurance business and its insurance distribution activities.

NHBC is registered in England and Wales under company number 00320784. NHBC's registered address is NHBC House, Davy Avenue, Knowlhill, Milton Keynes, Bucks, MK5 8FP. Note that only certain parts of NHBC's products and services are within the scope of UK financial services regulation. For more information on our products and services, please see our website [nhbc.co.uk](https://nhbc.co.uk) or your NHBC product documentation.