

Substructure and ground bearing floors

This chapter gives guidance on meeting the Technical Requirements and recommendations for substructures (excluding foundations), including: substructure walls, ground bearing floors where infill is no deeper than 600mm, and installation of services below the damp proof course (DPC).

5.1.1	Compliance	01
5.1.2	Provision of information	01
5.1.3	Transfer of loads	01
5.1.4	Ground conditions	01
5.1.5	Services and drainage	02
5.1.6	Ground below fill	03
5.1.7	Fill below floors	03
5.1.8	Infill up to 600mm deep	04
5.1.9	Materials used for fill	04
5.1.10	Harmful or toxic materials	04
5.1.11	Regulatory solutions	05
5.1.12	Walls below DPC	05
5.1.13	Durability	06
5.1.14	Mortar	07
5.1.15	Wall ties	07
5.1.16	Blinding	07
5.1.17	Ground floor slab and concrete	07
5.1.18	Laying the ground-bearing floor slab	08
5.1.19	Damp proof course	08
5.1.20	Damp proofing concrete floors	09
5.1.21	Thermal insulation	09
5.1.22	Installation of insulation	10
5.1.23	Further information	10

For figure reference tables in this chapter, please go to the end of the chapter



5.1.1 Compliance

Also see: Chapter 2.1

Substructures and ground-bearing floors shall comply with the Technical Requirements.

Substructures and ground-bearing floors that comply with the guidance in this chapter will generally be acceptable.

Ground-bearing floors may only be used where the depth of infill is less than 600mm deep and properly compacted.

5.1.2 Provision of information

Designs and specifications shall be produced in a clearly understandable format, include all relevant information and be distributed to appropriate personnel.

Design and specification information should be issued to site supervisors, relevant specialist subcontractors and suppliers, and include the following information:

- plan dimensions and levels which should be related to benchmarks
- the required sequence and depth of trench backfill where relevant to the design of the walls below the DPC
- details of trench backfill, infill and void formers
- work required to maintain the integrity of DPCs and damp proof membranes (DPMs)
- information on proposed underground services, including points of entry to the building
- detailing of service penetrations through the substructure, including support of the structure above details of junctions between the DPM, DPC and tanking
- details of underfloor, floor edge and cavity insulation
- details of ground hazards and mitigation measures.

5.1.3 Transfer of loads

Also see: Chapters 4.1, 4.3, 5.2 and 6.1

Substructures and ground-bearing floors shall ensure that loads are supported and transferred to the foundations, or ground, without undue movement.

The design of the substructure should take account of findings from the site investigation. Where infill deeper than 600mm is needed, a suspended floor should be used.

Load-bearing partitions should have proper foundations and not be supported off ground-bearing floors. In Scotland, sleeper walls should not be built on ground-bearing floors.

5.1.4 Ground conditions

Also see: Chapters 4.1, 4.2, 5.2, 10.1 and BRE Report 211

Substructure and ground-bearing floors shall not be adversely affected by ground conditions, and take account of:

- | | |
|-----------------------------------|--|
| a) ground hazards | d) effect of sloping ground on depth of infill and wall construction |
| b) bearing capacity of the ground | e) site works and construction. |
| c) nature of the ground | |

Ground hazards

Hazards likely to affect substructure and ground-bearing floors include contaminated materials, waterlogged ground and chemicals, particularly sulfates.

Where it is necessary to reduce the entry of hazardous gas, which should be identified in the site investigation, such precautions should be acceptable to NHBC.

Bearing capacity

Ground-bearing floors may not be suitable where the bearing capacity and nature of the ground varies, even where the depth of infill is less than 600mm. Special measures may be needed to restrict settlement, such as the use of suspended floor construction.

Nature of the ground

Where there is shrinkable soil, expansive materials or other unstable soils, suspended floor construction may be necessary.

Shrinkable soils are classified as those which contain more than 35% fine particles (silt and clay) and which have a Modified Plasticity Index of 10% or more. A soil testing laboratory should be consulted to verify the Plasticity Index of the soil.

The effect of sloping ground

Sloping ground may require steps in the substructure and possibly different floor levels.

Where more than 600mm of infill is required at any point in a self-contained area, the floor over the whole of that area must be of suspended construction.

Construction on steep slopes may involve walls below DPC level acting as retaining walls and should be designed by an engineer where (H) is greater than four times (T) or H exceeds 1m.

- (H) = height difference between floor/ground levels
- (T) = the total thickness of the retaining wall.

Figure 1: Substructure on sloping ground

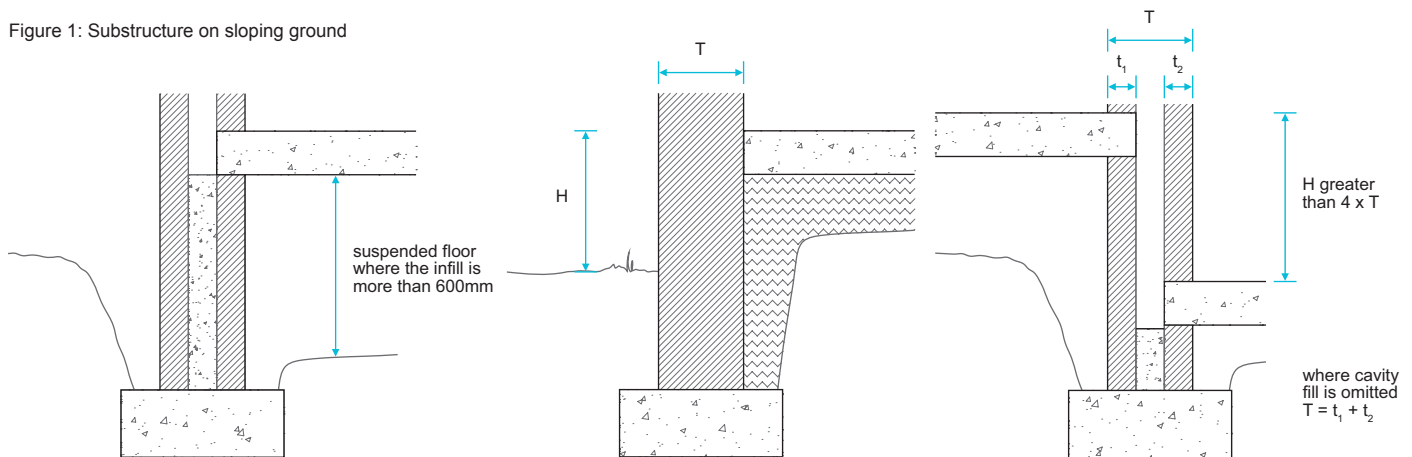

Site works and construction

Special precautions may be needed to prevent damage to the substructure from site operations on adjoining ground such as ground treatment, or surcharging due to infill.

5.1.5 Services and drainage

Also see: Chapters 5.3, 5.4, 6.2 and 8.1

Substructure and ground-bearing floors shall be installed to:

- | | |
|---|--|
| a) adequately protect existing services and ground water drainage | b) have suitable surface and subsoil drainage |
| | c) make allowance for drainage and other services. |

Adequately protect existing services and ground water drainage

All existing services should be located and identified before work commences. During dry periods it can be difficult to determine if ground water drains are active, so where they are severed or disturbed, they should be reconnected to a suitable outfall.

Existing active groundwater drainage should be retained to minimise the risk of flooding. Water from these drains may require diverting.

Where existing services conflict with the proposed foundations or substructure, and they are to remain, they should be protected or diverted and remaining voids filled with concrete or grout. Where they are no longer active and are not needed, they should be disconnected and removed.

Figure 2: Diversion of existing services

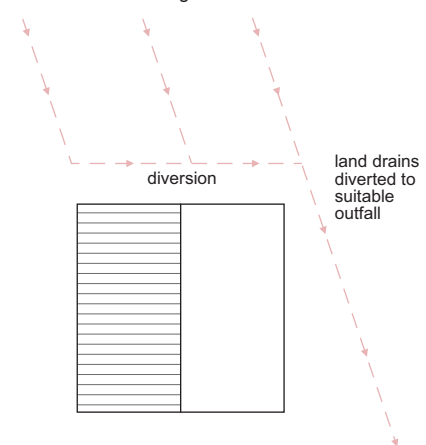

Surface water and subsoil drainage

Surface and/or subsoil drainage may be needed on sites where there is a risk of waterlogging.

Walls which act as retaining walls may require land drains, hardcore fill and suitable outlets to dispose of any subsoil water that collects behind the wall.

Ground or paths adjoining the home should:

- slope away at a slight fall
- generally be at least 150mm below the DPC.

Make allowance for drainage and other services

Design information should include all necessary details relating to the proposed underground services.

Drain pipes passing through or under the building may require flexible connections or other means of accommodating differential movement.

Pipes passing through substructure walls should accommodate movement by:

- a 50mm clearance all round, or
- a sleeve, with 50mm clearance all round and suitably sealed, or,
- bedded pipes, connected on both sides of the wall with flexible joints located as close as is feasible to the outside face of the wall but at a maximum of 150mm from the face of the wall.

Flexible joints should be made in accordance with the pipe manufacturer's recommendations.

Figure 3: Pipes bedded in walls with flexible joints

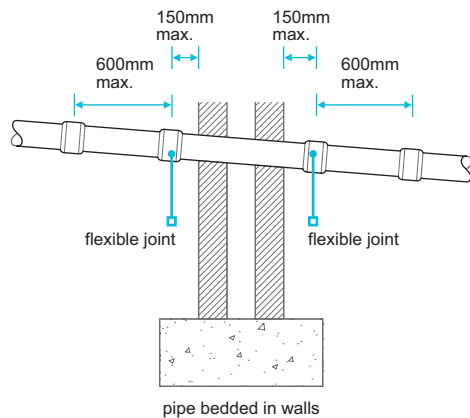

Figure 4: Pipes passing through a lintelled opening

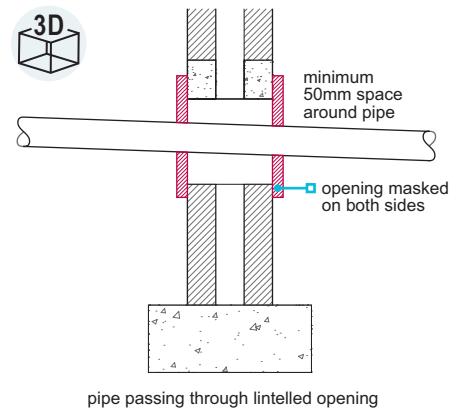
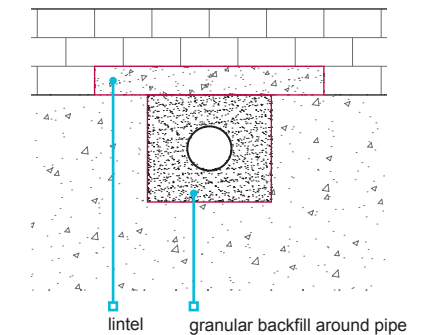

Figure 5: Backfill around pipes within openings



Where required, they should be arranged so that future access can be obtained without affecting structural stability.

When unidentified services, ducts, cables or pipes are exposed, advice should be sought from local offices of statutory undertakings and service supply companies.

5.1.6 Ground below fill

Ground below fill shall be adequately prepared to provide consistent support to the fill and the ground-bearing slab without undue movement.

Ground-bearing floor slabs may only be built on ground where:

- the ground is suitable to support floor loads and any other loads
- all topsoil containing vegetation and organic matter, including tree roots, has been removed
- there is a suitable and even bearing surface.

5.1.7 Fill below floors

Fill, including made ground, trench backfill and infill below ground-bearing floor slabs shall provide full and consistent support to ground-bearing slabs.

Where more than 600mm of infill is required at any point within a self-contained area, or the bearing capacity and nature of the ground varies, the floor over the self-contained area should be of suspended construction.

Infill under slabs and backfill in trenches should be properly placed and mechanically compacted to form a stable mass in layers not exceeding 225mm. Concrete may be used as an alternative to backfill in trenches.

Figure 6: Infill under slab and backfill in trenches

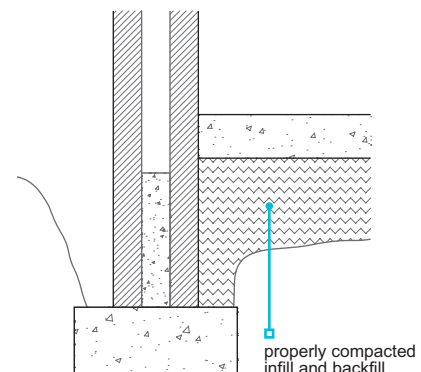

5.1.8 Infill up to 600mm deep

Also see: Chapter 5.2

Infill beneath ground-bearing floors shall be a maximum of 600mm deep.

Ground-bearing slabs are not acceptable where infill exceeds 600mm in depth.

Where the design requires in excess of 600mm of infill at any point within a self-contained area, the floor construction over the whole of that area is required to be independent of the fill and capable of supporting:

- self-weight
- non load-bearing partitions
- other imposed loads.

Generally this should be achieved with the use of a suspended slab. See Chapter 5.2.

5.1.9 Materials used for fill

Also see: Chapter 4.6, BRE DG 522 'Hardcore for supporting ground floors of buildings'

Materials used for fill shall be suitable for the intended use and, unless appropriate precautions are taken, free from hazardous materials. Issues to be taken into account include:

a) sources of fill materials

b) hazardous materials.

Fill should be:

- well graded
- inert and contain no hazardous materials
- able to pass a 150mm x 150mm screen in all directions.

Fill containing either expansive materials or chemicals is not acceptable for the support of ground-bearing slabs.

The following types of fill should not be used unless written permission has been obtained from NHBC:

- material obtained from demolition
- furnace ashes and other products of combustion
- colliery shale and any other residue from mineral extraction
- slags
- on wet sites, or sites with a high water table, crushed or broken bricks which have S1 designation according to BS EN 771.

Sources of fill material

Where the material is of a stable and uniform type, and from one source, it may only be necessary to check its suitability once. Where material is variable, or from a number of sources, it should all be suitable, and regular inspections and/or testing may be required.

Where industrial waste is permitted as fill material, it is essential that sufficient testing is carried out to ensure suitability.

Where material is obtained from stockpiles, check the material is uniform. Different forms of stockpiling can affect particle size/grading. The outside of a stockpile may be weathered and may not be the same as unweathered material.

Hazardous materials

The following fill materials require testing to ensure their suitability for use with ground-bearing slabs or as backfill to associated trenches:

- reactive materials
- organic materials
- toxic materials
- materials that include sulfates, eg gypsum
- materials that cause noxious fumes, rot, undue settlement or damage to surrounding materials
- acid wastes.

5.1.10 Harmful or toxic materials

Also see: BRE DG 522 'Hardcore for supporting ground floors of buildings'

Harmful or toxic materials present in the fill or in the ground shall be identified to the satisfaction of NHBC and not affect the performance of the substructure and ground-bearing slab.

Precautions should be taken by either:

- ensuring that made ground and fill materials are free from harmful or toxic substances, or
- designing the construction to contain, resist and prevent the adverse effects of such materials, using means acceptable to NHBC.

Tests for sulfate content should comply with the recommendations of BRE Special Digest 1 Third Edition by a suitably qualified person who has a detailed knowledge of the:

- material being tested
- proposed conditions of use.

The samples tested must be representative of the material, so it may be necessary to collect multiple samples to identify characteristics.

Where there are likely to be harmful levels of sulfate:

- the floor slab should be of an appropriate mix to resist sulfate attack or be protected by an impervious layer of 1200 gauge (0.3mm) polyethylene sheet, or 1000 gauge (0.25mm) where it complies with Technical Requirement R3. This may also serve as a DPM
- the concrete blocks in substructure walls should be sulfate resistant and suitable for the fill and ground conditions
- the mortar should be sulfate resisting to comply with BS EN 1996-1-1.

Fill containing expansive materials or chemicals is not acceptable for use as infill or backfill.

5.1.11 Regulatory solutions

Use of recycled or secondary materials shall comply with the relevant waste regulatory requirements.

Table 1: Regulatory solution for fill, including recycled and secondary materials

Location	Materials used on	Regulatory solution
England and Wales	Site of origin	CL:AIRE Code of Practice
	Other sites and less than 5000t	Registration under a U1 exemption with the EA is required at the receiving site
	Other sites and over 5000t	Ensure that the supplier has followed the WRAP protocol
Northern Ireland and Scotland	Any site	Registration under a paragraph 19 exemption with the SEPA/NIEA is required at the receiving site

EA: Environment Agency
CL:AIRE: Contaminated Land: Applications in Real Environments

NIEA: Northern Ireland Environment Agency
SEPA: Scottish Environment Protection Agency

5.1.12 Walls below the DPC

Also see: Chapters 6.1 and 6.2

Substructure and walls below the DPC shall be suitably constructed. Issues to be taken into account include:

- construction of walls acting as temporary retaining walls
- concrete cavity fill.

Construction of walls acting as temporary retaining walls

Backfill should be placed in layers of equal thickness to both sides of the substructure walls, so that compaction on one side is not more than one layer ahead of the other. Where backfill is placed and compacted on one side of the foundation trench before the other side is backfilled, the wall will be acting as a temporary retaining wall.

In such cases, the wall should either be designed by an engineer in accordance with Technical Requirement R5 or the thickness (T) should be as indicated in Table 2.

Figure 7: Substructure walls acting as temporary retaining walls

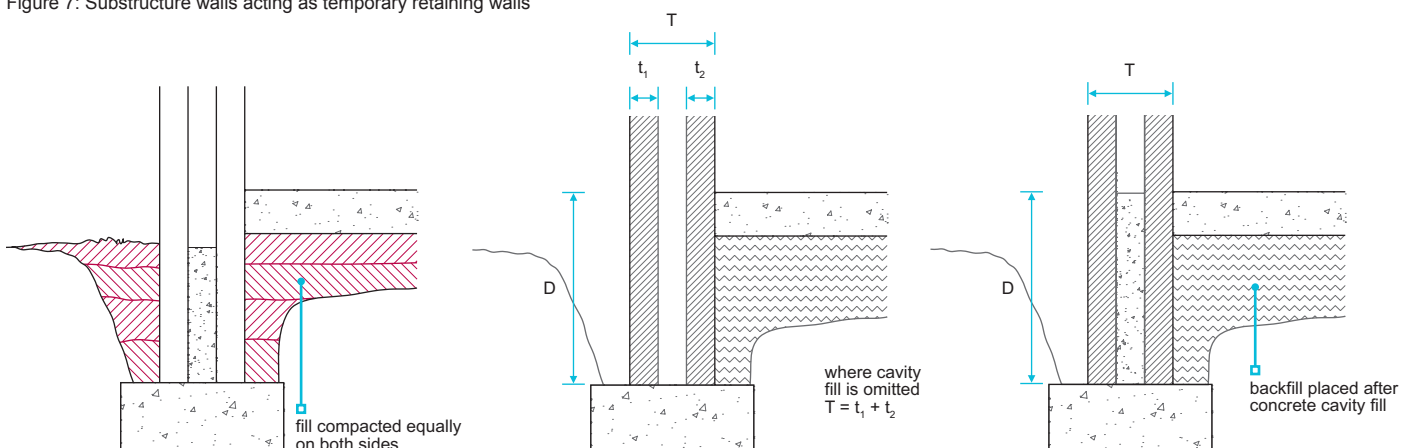

Table 2: Acceptable D:T of temporary retaining walls

Depth (D) of filled trench	Minimum thickness (T) of wall leaf supporting fill
Up to 1100mm	200mm
1100-1400mm	300mm
1400-1700mm	400mm
1700-2000mm	500mm

This guidance is only applicable to the temporary condition and where problems such as hydrostatic pressure are not present.

Concrete cavity fill

A minimum 225mm clear cavity below the DPC should be maintained. When specialised foundations are used, including those for timber framed buildings, the minimum clear cavity depth may be reduced to 150mm below the DPC, provided that weepholes and other necessary measures are taken to ensure free drainage. For further guidance see Clause 4.4.13.

5.1.13 Durability

Also see: Chapters 4.3, 6.1 and BS EN 1996-1-1

Substructure and walls below the DPC shall be capable of supporting their intended loads and, where necessary, be resistant to frost action, sulfates and other harmful or toxic materials. Issues to be taken into account include:

a) brickwork

b) blockwork.

Frost damage occurs on saturated masonry exposed to freezing conditions. Bricks, blocks and mortars located 150mm above and below ground level are the most likely to be damaged by frost.

Masonry walls below the DPC should be designed and constructed as described in Chapter 6.1 'External Masonry Walls'.

Recommendations for the design strength of bricks, masonry blocks and mortars are given in BS EN 1996-1-1.

Brickwork

Bricks should be of suitable durability, especially in the outer leaf below the DPC, or where they could be frozen when saturated. Bricks used in retaining walls should be suitable for the exposure and climate, as recommended by the manufacturer.

Clay bricks should comply with BS EN 771, which classifies bricks according to their durability designation (F) and to the content of active soluble salts (S).

F0	Not freeze/thaw resistant and should not be used externally
F1	Moderately freeze/thaw resistant
F2	Freeze/thaw resistant
S1	Normal active soluble salts
S2	Low active soluble salts

Generally, bricks are designated to F1,S2 or F1,S1. If in doubt as to suitability, bricks of F2,S2 or F2,S1 should be specified, or the manufacturer consulted and written confirmation obtained in relation to:

- geographical location
- location in the structure.

Calcium silicate bricks for use below DPC should be at least compressive strength class 20.

Blockwork

Concrete blocks for use below the DPC should meet BS EN 771 and one of the following:

- minimum density of 1500kg/m³, or
- assessed in accordance with Technical Requirement R3.
- minimum compressive strength of 7.3N/mm², or

Where it is necessary to resist sulfate attack and ensure adequate durability, blocks made with sulfate-resisting cement and/or a higher than normal cement content should be used.

Where there is doubt regarding the suitability of the block, particularly where acids or sulfates occur, written confirmation of its suitability should be obtained from the manufacturer in relation to:

- geographical location
- location in the structure.

5.1.18 Laying the ground-bearing floor slab

Also see: Chapters 3.1 and 9.3

Ground-bearing floors shall be reasonably level and effectively impervious to moisture.

All underfloor services and ducts should be installed and tested before concreting, where appropriate.

Care should be taken to ensure that all joints and junctions between DPMs, wall DPCs or tanking in substructure walls are undamaged, especially while the concrete for the ground slab is being poured.

Figure 8: DPM/DPC protected during installation of a concrete slab

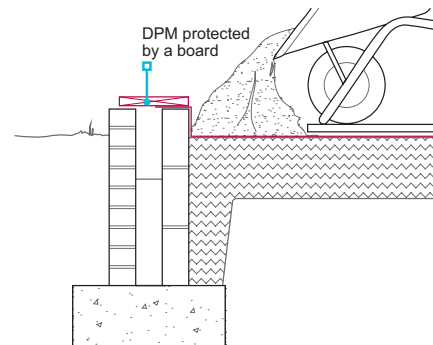

5.1.19 Damp proof course

Also see: Chapters 5.4, 6.1 and 6.3

Damp proof courses shall adequately resist moisture from reaching the inside of the building. Issues to be taken into account include:

a) positioning of DPCs

b) DPC materials.

Positioning of DPCs

DPCs should be:

- positioned a minimum of 150mm above external finished ground or paving level
- linked with any DPM
- of the correct width and fully bedded
- either welded or lapped by 100mm minimum
- impermeable.

Figure 9: DPC at least 150mm above finished ground level

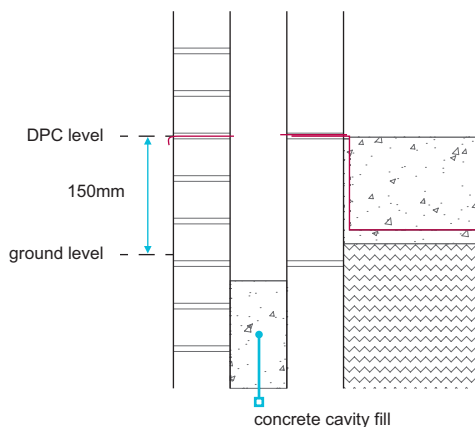
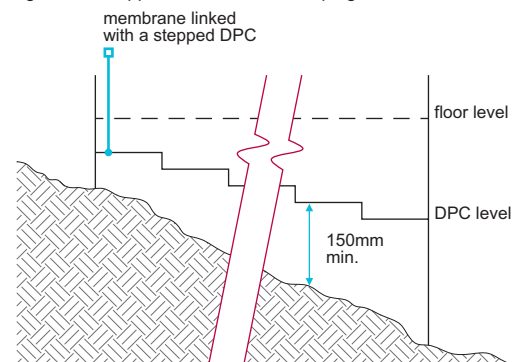

Figure 10: Stepped DPC levels on sloping sites



Where homes are 'stepped' on a sloping site, care should be taken to link DPCs and DPMs so that all parts of each home are protected.

DPC materials

Acceptable materials for DPCs include:

Bitumen based materials	BS 6398 BS EN 14967
Polyethylene, (should not be used below copings, in parapets or for tanking)	BS 6515 BS EN 14909
Proprietary materials	Technical Requirement R3

DPCs and flexible cavity trays should be of the correct dimensions. At complicated junctions, preformed cavity trays of the correct type and shape should be used.

Brick DPCs are only suitable to resist the upward movement of moisture and should:

- consist of two courses of engineering bricks, laid broken bond
- be bedded and jointed in a 1:¼:3, cement:lime:sand, or equivalent, mortar.

5.1.20 Damp proofing concrete floors

Ground-bearing floors shall resist the passage of moisture to the inside of the home.

Ground-bearing concrete floor slabs should be protected against ground moisture by providing a continuous damp proof membrane (DPM). The DPM should:

- have sealed laps of at least 300mm wide
- link with wall DPCs to form an impervious barrier to prevent moisture reaching the interior of the dwelling
- take account of possible differential movement.

Care should be taken not to trap moisture when a combination of damp proofing and vapour control layers are used.

When the DPM is located below the slab, a blinding layer of sand should be provided to fill voids in the hardcore and to minimise the risk of puncturing the membrane.

A clear cavity of at least 225mm below the DPC should be maintained. When specialised foundations are used, including those for timber framed buildings, this depth may be reduced to 150mm below the DPC where weepholes are provided and other necessary measures are taken to ensure that the cavity can drain freely.

Where homes are stepped down a sloping site, the DPCs and DPMs should be linked so that all parts of each home are protected. The guidance in Chapter 5.4 'Waterproofing of basements and other below ground structures' should be followed where steps between floor slabs are greater than 150mm.

Suitable materials for DPMs include:

- 1200 gauge (0.3mm) polyethylene sheet
- minimum 1000 gauge (0.25mm) polyethylene sheet where it complies with Technical Requirement R3
- bitumen sheet to BS 6398
- materials that comply with Technical Requirement R3.

Figure 11: 225mm clear cavity below DPC

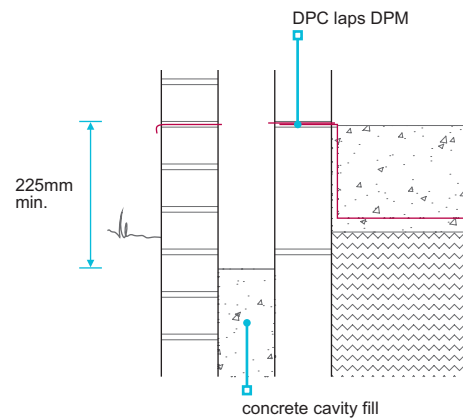

5.1.21 Thermal insulation

Also see: Chapters 6.1, 9.3 and BRE Report 'Thermal insulation: avoiding risks'

Ground-bearing floors and walls below the DPC shall be thermally insulated to comply with Building Regulations and be suitable for the intended use. Issues to be taken into account include:

- | | |
|---------------------|----------------------|
| a) floor insulation | c) thermal bridging. |
| b) wall insulation | |

Floor insulation

Thermal insulation materials for use below ground-bearing slabs should have:

- appropriate density for the location
- low water absorption.

Insulation to be positioned below both the slab and DPM should be resistant to ground contaminants. The following materials are acceptable for use as insulation:

- expanded polystyrene boards (grade EPS 70) to BS EN 13163
- a proprietary material that complies with Technical Requirement R3.

Wall insulation

Cavity insulation materials, super lightweight blocks, blocks with face bonded insulation or integral insulation should be:

- manufactured and used to comply with a British Standard and relevant code of practice, or
- used in compliance with Technical Requirement R3.

The thickness of materials for masonry cavity walls should be suitable for the required level of performance, see Clause 6.1.7.

Thermal bridging

The design should ensure that any risk of thermal bridging is minimised, especially at junctions between floors and external walls. Precautions include:

- extending cavity insulation below floor slab level
- linking floor and wall insulation
- providing perimeter insulation to floors
- facing supporting substructure with insulation – where homes are stepped or staggered, the wall forming the step or stagger may require insulation
- particular attention should be paid to ensuring thermal bridging is addressed at door openings.

5.1.22 Installation of insulation

Installation of thermal insulation shall ensure that the full thermal performance of the floor is achieved.

Insulation boards should be tightly butted together to maintain insulation continuity. Where the insulation is turned up vertically at the edge of the slab, it should be protected whilst the concrete is being poured and tamped.

Figure 12: Protection of perimeter insulation board during installation of concrete floor

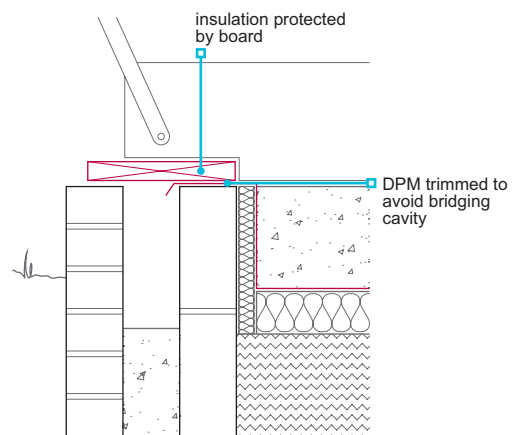

5.1.23 Further information

- BRE Digest 433.

Figure reference table

Figure reference table 5.1			
Fig No	Title/Description	Clause	Page
Figure 1	Substructure on sloping ground	5.1.4	2
Figure 2	Diversion of existing services	5.1.5	2
Figure 3	Pipes bedded in walls with flexible joints	5.1.5	3
Figure 4	Pipes passing through a lintelled opening	5.1.5	3
Figure 5	Backfill around pipes within openings	5.1.5	3
Figure 6	Infill under slab and backfill in trenches	5.1.7	3
Figure 7	Substructure walls acting as temporary retaining walls	5.1.12	5
Figure 8	DPM/DPC protected during installation of a concrete slab	5.1.18	8
Figure 9	DPC at least 150mm above finished ground level	5.1.19	8
Figure 10	Stepped DPC levels on sloping sites	5.1.19	8
Figure 11	225mm clear cavity below DPC	5.1.20	9
Figure 12	Protection of perimeter insulation board during installation of concrete floor	5.1.22	10



Chapter 5.2



Suspended ground floors

This chapter gives guidance on meeting the Technical Requirements for suspended ground floors including those constructed from:

- in-situ concrete
- precast concrete
- timber joists.

5.2.1	Compliance	01
5.2.2	Provision of information	01
5.2.3	Contaminants	01
5.2.4	Proprietary systems	01
5.2.5	Transfer of loads: concrete floors	01
5.2.6	Reinforced concrete	02
5.2.7	Construction of suspended concrete ground floors	02
5.2.8	Transfer of loads: timber floors	02
5.2.9	Thermal insulation and thermal bridging	03
5.2.10	Damp proofing and ventilation	03
5.2.11	Floor finishes	04
5.2.12	Floor decking	04

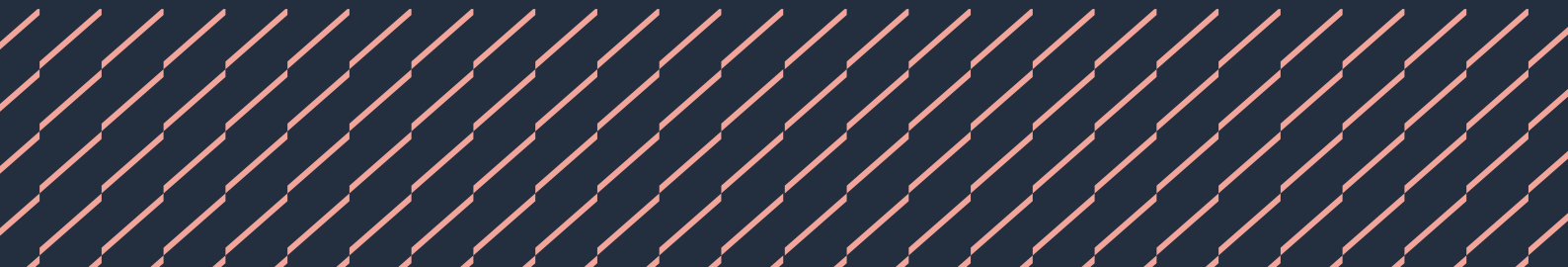

5.2.1 Compliance

Also see: Chapters 2.1, 4.1, 4.2, 4.5 and 5.1

Suspended ground floors shall comply with the Technical Requirements.

Suspended ground floors that comply with the guidance in this chapter will generally be acceptable.

Ground floors should be constructed as suspended floors where:

- the depth of fill exceeds 600mm
- there is shrinkable soil that could be subject to movement (See Chapter 4.2 'Building near trees'), expansive materials or other unstable soils
- the ground has been subject to vibratory improvement
- ground or fill is not suitable to support ground-bearing slabs.

5.2.2 Provision of information

Designs and specifications shall be produced in a clearly understandable format, include all relevant information and be distributed to all appropriate personnel.

Design and specification information should be issued to site supervisors, relevant specialist subcontractors and suppliers, and include the following information:

- all necessary plan dimensions and levels related to identified benchmarks
- details of load-bearing walls
- minimum bearing dimensions
- information on all proposed underground services
- points of entry to the building for services
- details of trench backfill, infill and void formers
- details of junctions between DPM, DPC and tanking
- details of underfloor and floor edge insulation and cavity insulation, where relevant
- span and direction of structural members
- details of non-loadbearing walls
- details of ground hazards and mitigation measures.

5.2.3 Contaminants

Also see: Chapter 4.1, 10.1 and BRE Report 211

Suspended ground floors shall be designed and constructed to ensure that adequate measures are taken against the adverse effects of ground contaminants, including adequate protection against hazardous gas.

Any contaminants in, or above, the ground should be identified to the satisfaction of NHBC, following the guidance given in the appropriate British Standard, and precautions against health hazards caused by contaminants should be taken.

Precautions acceptable to NHBC may be necessary to reduce the entry of hazardous gas; such conditions should be identified in the site investigation.

5.2.4 Proprietary systems

Proprietary suspended flooring systems shall have adequate strength and durability.

Proprietary concrete flooring systems should be designed in accordance with BS EN 1992-1-1. Where a system incorporates elements which cannot be designed to this standard, eg polystyrene infill blocks, the floor should be assessed in accordance with Technical Requirement R3.

5.2.5 Transfer of loads: concrete floors

Also see: Chapters 4.1, 4.2, 5.2 and BRE Report 211

Suspended ground floors shall be designed and constructed to transmit all loads safely to the supporting structure without undue movement. Issues to be taken into account include:

- a) dead and imposed loads
- b) end bearings.

Dead and imposed loads

In-situ:

Loads should be calculated in accordance with BS EN 1991-1-1.

Suspended in-situ concrete ground floors should be designed either:

- by an engineer in accordance with Technical Requirement R5, or
- in accordance with BS 8103-1.

Precast:

Loads should be calculated in accordance with BS EN 1991-1-1.

Precast concrete suspended ground floors should be:

- designed by an engineer in accordance with Technical Requirement R5
- proprietary systems which have been assessed in accordance with Technical Requirement R3, or
- chosen from the manufacturer's details which are based on recognised standards and codes of practice.

End bearings**In-situ:**

Bearings on supporting walls should be designed either:

- by an engineer in accordance with Technical Requirement R5, or
- in accordance with BS 8103-1.

Precast:

Bearings on supporting walls should be as recommended by the manufacturer, and in no case less than 90mm.

5.2.6 Reinforced concrete

Also see: Chapter 3.1

Suspended ground floors shall use suitably mixed and reinforced concrete, which will achieve sufficient strength to support floor loads safely and be sufficiently durable to remain unaffected by chemical or frost action.

Guidance for the specification and use of in-situ concrete, additives and reinforcement is contained in Chapter 3.1 'Concrete and its reinforcement'.

5.2.7 Construction of suspended concrete ground floors

Also see: Chapter 6.4

Suspended ground floors shall be designed and constructed to ensure the safe support of the intended loads and be reasonably level.

In-situ:

Concreting should be carried out in accordance with:

- the design information
- relevant parts of NHBC guidance for concrete, including Chapter 3.1 'Concrete and its reinforcement'.

Precast:

Care should be taken to ensure that DPCs are not damaged or displaced. All sitework for precast concrete floors should be carried out in accordance with the manufacturer's recommendations.

5.2.8 Transfer of loads: timber floors

Also see: Chapters 4.3 and 6.4

Timber suspended ground floors, including the decking material, shall be designed and constructed to be suitable for their intended use. Issues to be taken into account include the:

- | | |
|--|---|
| a) support of self-weight, dead and imposed loads and limited deflection | b) safe transmission of loads to the supporting structure |
| | c) adverse effects of shrinkage and movement. |

Support of self-weight, dead and imposed loads, and limited deflection

Structural timber grades and sizes should be adequate for the spans and imposed loads. Where trimming is necessary, adequately sized timbers should be used.

Structural timber components should be of a suitable strength class as specified by the designer to BS EN 338. Solid structural timber should be:

- machine graded to BS EN 14081, or visually graded to BS 4978 for softwoods or BS 5756 for hardwoods
- dry graded
- assigned a strength class based on BS EN 1912 when visually graded
- marked in accordance with BS EN 14081.

Further guidance on strength classes for certain timber species can be found in PD 6693.

Engineered wood products such as I-section or metal-web joists should be assessed in accordance with Technical Requirement R3.

For guidance on floor joist deflection limits, see Clause 6.4.9.

Safe transmission of loads to the supporting structure

Joist hangers should be suitable for:

- the joist width and depth
- the strength of masonry
- the loading
- providing adequate end bearings to joists.

Sleeper walls should adequately support the floor joists, and joists should be correctly supported at masonry separating walls. Sleeper walls should not limit ventilation.

Shrinkage and movement

Strutting should be provided where required following the guidance in Clause 6.4.15.

5.2.9 Thermal insulation and thermal bridging

Also see: Chapter 9.3 and BRE Report 'Thermal insulation: avoiding risks'

Suspended ground floors shall be insulated in accordance with Building Regulations to minimise thermal transmission through the floor and using materials suitable for the location and intended use.

Insulation should be installed to ensure that any risk of thermal bridging is minimised, especially at junctions between floors and external walls. Thermal bridging precautions include:

- extending cavity wall insulation below floor level
- providing perimeter insulation to floors.

Insulation below cast in-situ suspended ground floor slabs should be:

- placed on a suitable, compacted and even substrate
- of a material with low water absorption
- resistant to ground contaminants
- strong enough to support wet construction loads
- compatible with any DPM.

Insulation for timber floors may be either insulation quilt or rigid insulation.

Cavity wall insulation should extend below the floor insulation level.

Insulation for use above suspended concrete floors should be in accordance with Chapter 9.3 'Floor finishes'.

Particular attention should be paid to ensuring thermal bridging is addressed at door openings.

5.2.10 Damp proofing and ventilation

Also see: Chapters 4.2, 5.1, 5.4, 6.1, 6.3 and 9.3

Suspended ground floors shall be designed and constructed to resist the passage of moisture into the building. Issues to be taken into account include:

- a) damp proofing
- b) ventilation.

Damp proofing

Where DPMs are required, they should be linked with any DPCs in the supporting structure, in order to provide continuous protection from moisture from the ground or through the supporting structure.

DPMs should be properly lapped in accordance with Chapter 5.1 'Substructure and ground-bearing floors'.

In-situ concrete:

Dampness from the ground and supporting structure should be prevented from reaching the floor by using linked DPMs and DPCs to provide continuous protection.

Where there is a risk of sulfate attack, in-situ or oversite concrete should be protected with polyethylene sheet that is a minimum:

- 1200 gauge (0.3mm), or
- 1000 gauge (0.25mm) if assessed in accordance with Technical Requirement R3.

Precast concrete:

Additional damp proofing may not be necessary where:

- the underfloor void is ventilated in accordance with CP 102 and DPCs are provided under bearings of precast floors
- ground below the floor is effectively drained, if excavated below the level of the surrounding ground.

Where proprietary floor systems are used, adequate moisture-resistant membranes should be installed in accordance with the manufacturer's recommendations.

Vapour control layers may be necessary to protect floor finishes and, where used, should be positioned in accordance with the manufacturer's recommendations.

Timber ground floors:

Timber used for suspended ground floors should either have adequate natural durability or be preservative treated in accordance with Chapter 3.3 'Timber preservation (natural solid timber)', and the ground below the floor covered with:

- 50mm concrete or fine aggregate on a polyethylene membrane laid on 50mm sand blinding, or
- 100mm concrete.

Ventilation

Ventilation should be provided to precast and timber suspended floors. This is generally provided by ventilators on at least two opposite external walls, with air bricks properly ducted in accordance with Chapter 6.1 'External masonry walls'. Where this is not possible, suitable cross ventilation should be provided by a combination of openings and air ducts. Ventilation should not be obtained through a garage.

Sleeper walls and partitions should be constructed with sufficient openings to ensure adequate through ventilation. If necessary, pipe ducts should be incorporated in adjoining solid floors, separating walls or other obstructions. Where underfloor voids adjoin ground bearing floors, ventilation ducts should be installed.

Void ventilation should be provided to whichever gives the greater opening area:

- 1500mm² per metre run of external wall
- 500mm² per m² of floor area.

Ventilators should be spaced at no more than 2m centres and within 450mm of the end of any wall.

A minimum ventilation void of 150mm should be provided below the underside of precast concrete and timber suspended floors. On shrinkable soil where heave could take place, a larger void is required to allow for movement according to the volume change potential.

- high volume change potential – 150mm (300mm total void)
- low volume change potential – 50mm (200mm total void).
- medium volume change potential – 100mm (250mm total void)

Where precast concrete floor planks are used over a DPM laid directly on fill on non-shrinkable soil, the fill should be inert and non-expansive, raised up to the underside of the floor slab and be well compacted. Where this is carried out, a ventilated void below the floor is not necessary.

5.2.11 Floor finishes

Finishes to suspended ground floors shall be protected where necessary, against damp, condensation or spillage.

Guidance for suitable floor finishes is given in Chapter 9.3 'Floor finishes'. Care should be taken to prevent trapping any water spillage below timber floors.

Other floor decking should be assessed in accordance with Technical Requirement R3 and should be installed in accordance with manufacturers' recommendations.

5.2.12 Floor decking

Floor decking shall be suitable for the intended purpose and be correctly installed.

Acceptable installation details and materials used for decking are detailed in Clause 6.4.19.



Chapter 5.3



Drainage below ground

This chapter gives guidance on meeting the Technical Requirements for foul, surface water and ground water drainage systems.

This chapter does not apply to the adoption of sewers under Section 104 agreement of the Water Industry Act 1991 or the Sewerage (Scotland) Act 1968. For information on standards required for adopted sewers, contact the local sewerage undertaker and other relevant authorities.

5.3.1	Compliance	01
5.3.2	Provision of information	02
5.3.3	Preliminary work	02
5.3.4	Foul and surface water disposal	02
5.3.5	Drainage system performance	03
5.3.6	Ground water drainage	04
5.3.7	Design to avoid damage and blockages	04
5.3.8	Durability	08
5.3.9	Septic tanks and cesspools	09
5.3.10	Septic tank outputs	10
5.3.11	Surface water soakaways	12
5.3.12	Component requirements	14
5.3.13	Excavation	15
5.3.14	Protection of pipework	15
5.3.15	Laying pipework	16
5.3.16	Protection of work	17
5.3.17	Testing	18



Definitions for this chapter

For the purposes of this chapter, the following definitions apply:

Access point	Provision to access a sewer or drain for maintenance or inspection and includes any manhole, inspection chamber or rodding eye
Curtilage	The area of land around a building, or group of buildings, which is for the private use of the occupants of the buildings
Freeboard	The distance between the design water level and the top of a structure, provided as a precautionary safety measure against early system failure
Gully	Assembly to receive water for discharge into a drainage system
Infiltration system	Are systems that are specifically designed to promote infiltration of surface water or treated effluent into the ground. There are many different types of drainage components which can be used to facilitate infiltration. Some of these include soakaways, infiltration trenches, infiltration basins and drainage fields for use in wastewater treatment
Inspection chamber	Structure with a removable cover constructed on a drain or sewer that permits the introduction of cleaning and inspection equipment from surface level, but does not provide access for personnel
Local authority	Includes an authority acting in any relevant capacity: including a Local Planning Authority (LPA), Lead Local Flood Authority (LLFA) or SuDS Approval Body (SAB)
Manhole	Structure with a removable cover constructed on a drain or sewer to permit entry by personnel
Manhole top	Upper part of a manhole or inspection chamber consisting of a frame and cover and/or grating
Private drain	Is a drain used for the drainage of one building or any buildings or yards appurtenant to buildings within the same curtilage
Public sewer	A sewer for the time being vested in a water company in its capacity as sewerage undertaker
Rising main	A sewer through which foul sewage and/or surface water is pumped
Satisfactory outfall or effective discharge point	Point of discharge which has been specifically designed to discharge the foul sewage or surface water and for which there is a legal right to discharge. This can be another sewer or a watercourse (if there is a legal right to discharge) or an area of land or another infiltration drainage component
Septic tank	Is a form of wastewater treatment plant and refers to both traditional in-situ constructed septic tank as well as prefabricated septic tank (or small wastewater treatment systems for up to 50 PT) conforming to BS EN 12566

5.3.1 Compliance

Also see: Chapter 2.1

Drainage systems shall comply with the Technical Requirements.

Below ground drainage that complies with the guidance in this chapter will generally be acceptable.

All drainage schemes require the approval of the building control authority. Local sewerage undertakers may impose additional requirements and restrictions. Both should be consulted early, especially where the drainage system is to be adopted under a Section 104 agreement of the Water Industry Act 1991 or Sewerage (Scotland) Act 1968. The system may need to be inspected and tested by the sewerage undertaker, as well as by the local authority, building control authority and NHBC.

Satisfactory outfall disposal is essential where a septic tank or equivalent sewage treatment plant is installed. In England and Wales, Environment Agency consent may be required to discharge effluent from a septic tank or equivalent sewage treatment plant. In Northern Ireland, the NIEA should approve proposals; in Scotland, the local authority and, where appropriate, the river purification authority should approve proposals.

Ground conditions may preclude the use of septic tanks or equivalent sewage treatment plant in some locations. In all cases, NHBC will require evidence of a satisfactory percolation test where infiltration drainage system is being installed.

For surface water discharge into a watercourse, the permission of the Environment Agency is required in England and Wales. A 'consent to discharge' is required from the Department of the Environment in Northern Ireland. In Scotland, the local authority and, where appropriate, the river purification authorities should be consulted.

In all cases:

- relevant local authorities should be consulted and appropriate permissions sought before sitework begins
- NHBC will require evidence of a satisfactory percolation test where a septic tank or equivalent sewage treatment plant is being installed.

Table 1: Guide to relevant authority

	Septic tank discharge	Surface water discharge into a watercourse
England and Wales	Environment Agency DEFRA	
Northern Ireland	Northern Ireland Environment Agency	
Scotland	Local authority River purification authority	Local authority River purification authority Scottish Environmental Protection Agency

5.3.2 Provision of information

Designs and specifications shall be produced in a clearly understandable format, include all relevant information and be distributed to all appropriate personnel.

Design and specification information should be issued to site supervisors, relevant specialist subcontractors and suppliers, and include the following information:

- proposed drain layout
- invert levels and locations of existing sewers
- junctions
- ground floor levels of homes
- external finished levels
- inspection and access points
- method of disposal of both foul and surface water
- position of any septic tank or cesspool in relation to adjacent buildings
- results of percolation tests where treated effluent disposal is through field drains or surface water through soakaways
- length of field drains and their layout (including details of trench width as this is critical to the functioning of the system)
- depth of field drains
- details of drains or sewers intended for adoption
- details of soakaways (including size or volume and surrounding details).

5.3.3 Preliminary work

Drainage systems shall be checked on site to ensure that the design can be achieved.

Check that the following are as specified in the design:

- invert levels and locations of existing sewers
- ground floor levels of homes
- external finished levels.

Percolation tests should be verified where treated effluent disposal is through field drains. The length of any field drains specified in the design should be accommodated within the site boundaries.

5.3.4 Foul and surface water disposal

Also see: BS EN 752, Clause 5.3.11 and BRE Digest 365

Drainage systems shall be designed in accordance with relevant codes and standards to convey foul effluents and surface water satisfactorily to an appropriate outfall. Issues to be taken into account include:

- a) connections to sewers
- b) connections to surface water disposal systems
- c) rights of connection to disposal systems
- d) compatibility with other systems
- e) capacity of private sewers
- f) treatment plants for more than one home.

Connections to sewers

Connections to public sewers require the agreement of the responsible authority, which should be consulted as to the type and position of the connection.

Connections to private sewers require the agreement of the owners of the sewer. This should be obtained as part of the design process. Where the private sewer subsequently discharges into a public sewer, the local sewerage undertaker should be notified of the proposal.

Connections to surface water disposal systems

Surface water drainage is generally required to be separated from foul water drainage. Where permitted, surface water may be discharged into the main public surface water drains or directly into natural watercourses, ponds or soakaways, as appropriate. Surface water should not discharge to:

- septic tanks
- cesspools
- separate foul sewers.

For large or complicated homes, the volume of surface water to be disposed should be calculated in accordance with BS EN 12056-3.

Rights of connection to disposal systems

A legal right must exist when connecting drains to an outfall.

Compatibility with other systems

The drainage system should be compatible with the main sewerage system:

- with separate systems for foul water and surface water
- with separate systems where foul water is connected to the main sewer, while surface water disposal is by soakaways or other suitable means, or
- as a combined system.

Where the sewerage undertaker permits surface water drains to be connected to a foul water system:

- an interceptor should be installed on the surface water side of the foul sewer junction, or
- trapped gullies should be used.

Where ground water drains are connected to surface water drains, there should be a silt trap on the ground water side of the junction.

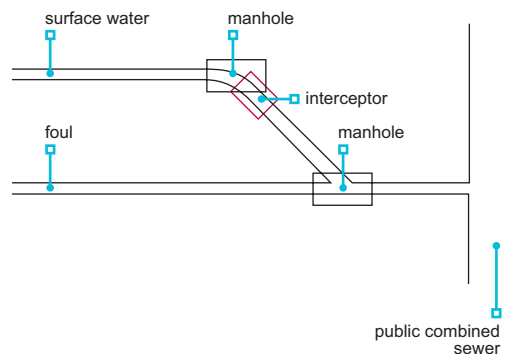

Capacity of private sewers

Private drainage systems should be:

- in accordance with BS EN 752
- sufficient to cope with the intended capacity.

Where an existing private drainage system is to be extended, or where the capacity is to be increased, sufficient investigation, measurement and calculation should be undertaken to ensure that all parts of the private system are of adequate capacity.

Treatment plants for more than one home

Small sewage treatment works for more than one home should be designed in accordance with BS EN 12566.

Discharge from the waste water treatment plant should be:

- sited at least 10m away from water courses and homes
- designed by a suitably qualified engineer.

5.3.5 Drainage system performance

Also see: Chapter 4.1, 8.1, BRE Report 211 and BRE Report 212

Drainage shall be suitably located and prevent health hazards. Issues to be taken into account include:

- | | |
|--|---|
| a) ventilation of drainage systems | c) siting of septic tanks and cesspools |
| b) prevention of gases entering the home | d) pumped systems. |

Ventilation of drainage systems

Ventilation of drains is normally achieved by ventilating discharge stacks.

Air admittance valves which comply with Technical Requirement R3 may be used in some homes to prevent trap seal siphonage. An open vent is generally required at the head of common drainage systems, and where the discharge pipe is the only vent for a septic tank or cesspool.

Prevention of gases entering the home

Where special precautions are necessary (eg sealing drains where they enter the building) to reduce the entry of gases such as radon or landfill gas, such precautions should be acceptable to NHBC.

Siting of septic tanks and cesspools

Septic tanks and cesspools should be:

- a minimum of 7m from homes
- a maximum of 30m from vehicular access to permit emptying.

In Scotland, a minimum distance of 5m from homes and boundaries is acceptable for septic tanks.

Pumped systems

Where a gravity system is not possible, pumped systems may have to be used and should be designed in accordance with BS EN 752 and BS 6297. The installation should include:

- a holding tank of sufficient volume to contain 24 hours of domestic effluent based on 120L/150L per head per day
- a suitable warning system providing visual and/or audible signals to indicate malfunction
- suitable equipment housing.

5.3.6 Ground water drainage

Ground water drainage shall convey excess ground water to a suitable outfall. Issues to be taken into account include:

- a) layout of pipes
- b) pipe construction.

Layout of pipes

Where ground water drainage is required, depending on the site contours and ground conditions, it may be designed as:

- a natural system
- a herringbone system
- a grid system
- a fan-shaped system
- a moat system.

Pipe construction

Pipe perforations should be holes or slots to suit the nature of the ground.

Ground water drain systems connected to foul, surface water or combined drains should discharge into the drain through a catchpit. Where suitable, ground water drainage may discharge into a soakaway, preferably through a catchpit or into a watercourse.

5.3.7 Design to avoid damage and blockages

*Also see: Chapter 4.2, BS EN 476,
BS EN 13598-1 & 2 and SFA-7*

Drainage systems shall minimise the risk of damage and blockage. Issues to be taken into account include:

- a) ground stability
- b) pipe runs
- c) pipe sizes
- d) gradients
- e) access and connections
- f) drainage covers and gully grids
- g) ground water
- h) flooding.

Ground stability

Proper allowance should be made for ground movement.

Pipes should have flexible joints and additional precautions taken to prevent leakage where required. Where ground movement could be significant, for example in made-up ground or clay soils, the following issues should be taken into account:

- the use of flexible pipes and flexible joints
- design gradients that are steeper than the minimum requirements for flow rate and pipe size
- a support system designed by an engineer in accordance with Technical Requirement R5
- conditions where ground movement is likely to adversely affect the drain.

In non-uniform or saturated soils where movement at the trench bottom can be expected, soft spots should be removed and replaced with suitable material. Immediately after excavation, the protective blinding should be placed in the trench bottom.

Pipe runs

Pipe runs should be designed to maintain a self-cleansing velocity (0.7 m/s). They should be as straight as practicable with minimal changes of direction. Bends should only occur in, or next to, inspection chambers and manhole covers. Curves should be slight so that blocked pipes can be cleared.

Pipe sizes

Pipe sizes should be designed for the maximum peak load in accordance with BS EN 752.

Ground water drains and soakaways should be designed with sufficient capacity for normal weather conditions.

Gradients

Design gradients should:

- be as even as practicable
- where flows are less than 1.0L/second, gradients for 100mm diameter pipes should not be flatter than 1:40
- where peak flows exceed 1.0L/second, the gradients in Table 2 may be used:

Table 2: Minimum gradients

Pipe diameter (mm)	Minimum gradient
100	1:80
150	1:150

Where peak flows are greater than 1.0L/second, 100mm pipes should serve a minimum of one WC and 150mm pipes should serve a minimum of five.

Access and connections

To ensure that every length of drain can be rodded, the design should include appropriately located access points, such as:

- rodding eyes
- access chambers
- inspection chambers
- manholes.

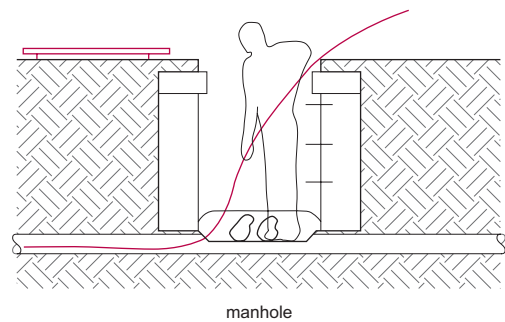
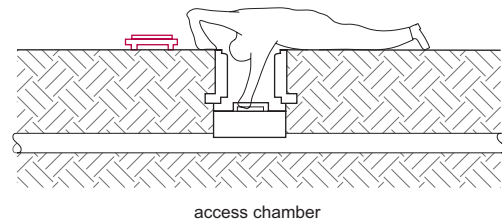
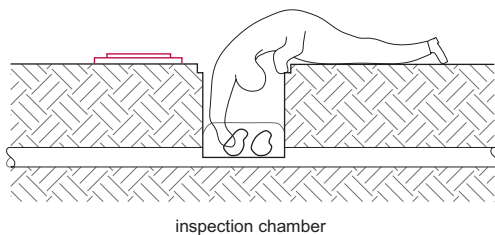

All access points should be located as shown in the design information and should:

- be accessible for rodding and cleaning
- not cross boundaries or kerb lines.

Inspection chambers and manholes should:

- be of sufficient size for the depth of invert, and
- the invert depth for the fitting or chamber should not exceeded those given in Table 3.

Table 3: Minimum dimensions for access fittings and inspection chambers

Type	Depth to invert from cover level (m)	Internal sizes		Cover sizes		
		Length x width (mm x mm)	Circular (mm)	Length x width (mm x mm)	Circular (mm)	
Rodding eye		As drain but min. 100			Same size as pipework ⁽¹⁾	
Small access fitting	150 dia. 150 x 100	0.6 or less, except where situated in a chamber	150 x 100	150	150 x 100 ⁽¹⁾	Same size as access fitting
Large access fitting	225 x 100		225 x 100	225	225 x 100 ⁽¹⁾	Same size as access fitting
Shallow inspection chamber	0.6 or less 1.2 or less	225 x 100 450 x 450	190 ⁽²⁾ 300 ⁽⁴⁾	– Min. 430 x 430	190 ⁽¹⁾ 310	
Deep inspection chamber	Greater than 1.2	450 x 450	300 ⁽⁵⁾ - 450	Max. 300 x 300 ⁽³⁾	Access restricted to max. 350 ⁽³⁾	

Notes

- 1 The clear opening may be reduced by 20mm in order to provide further support for the cover and frame.
- 2 Drains up to 150mm.
- 3 A larger clear opening cover may be used in conjunction with restricted access. The size is restricted for health and safety reasons to deter entry.
- 4 300mm diameter Inspection chamber complying with BS EN 13598-1.
- 5 300mm diameter Adoptable Inspection chamber complying with BS EN 13598-2 may be used up to depth of 2m.

Table 4: Minimum dimension for manholes

Type	Size of largest pipe (DN) (mm)	Minimum internal dimensions ⁽¹⁾		Min. clear opening size ⁽¹⁾	
		Rectangular length and width (mm)	Circular diameter (mm)	Rectangular length and width (mm)	Circular diameter (mm)
Manhole up to 1.5m deep to soffit	Equal to or less than 150	750 x 675 ⁽⁷⁾	1000 ⁽⁷⁾	750 x 675 ⁽²⁾	NA ⁽³⁾
	225	1200 x 675	1200	1200 x 675 ⁽²⁾	
	300	1200 x 750	1200		
	Greater than 300	1800 x (DN+450)	The larger of 1800 or (DN+450)		
Manhole greater than 1.5m deep to soffit	Equal to or less than 225	1200 x 1000	1200	600 x 600	600
	300	1200 x 1075	1200		
	375-450	1350 x 1225	1200		
	Greater than 450	1800 x (DN+775)	The larger of 1800 or (DN+775)		
Manhole shaft ⁽⁴⁾ greater than 3.0m deep to soffit pipe	Steps ⁽⁵⁾	1050 x 800	1050	600 x 600	600
	Winch ⁽⁶⁾	900 x 800	900	600 x 600	600
	Ladder ⁽⁵⁾	1200 x 800	1200		

Notes

- 1 Larger sizes may be required for manholes on bends or where there are junctions.
- 2 May be reduced to 600 x 600 where required by highway loading restrictions and subject to a safe system of work being specified.
- 3 Not applicable due to working space needed.
- 4 Minimum height of chamber in shafted manhole 2m from benching to underside of reducing slab.
- 5 Minimum clear space between ladder or steps and the opposite face of the shaft should be approximately 900mm.
- 6 Winch only; no steps or ladders, permanent or removable.
- 7 The minimum size of any manhole serving a sewer, ie, any drain serving more than one home, should be 1200mm x 675mm rectangular or 1200mm diameter.
- 8 Tables 3 & 4 have been reproduced from Tables 11 and 12 of Approved Document H by permission of HMSO.

Inspection chambers and manholes may be one of the following types:

- open, half-round section channel with suitable benching
- closed access, where covers have to be removed to gain access to the pipe.

Side branches to inspection chambers and manholes should discharge into the main channel no higher than half pipe level. Connections should be made obliquely in the direction of flow.

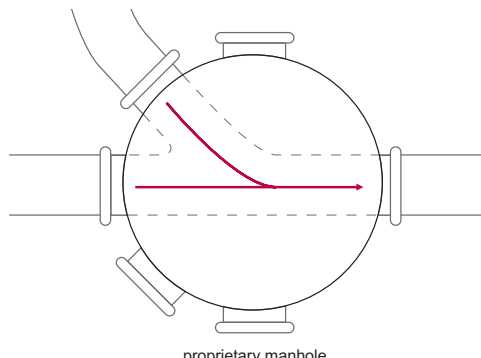
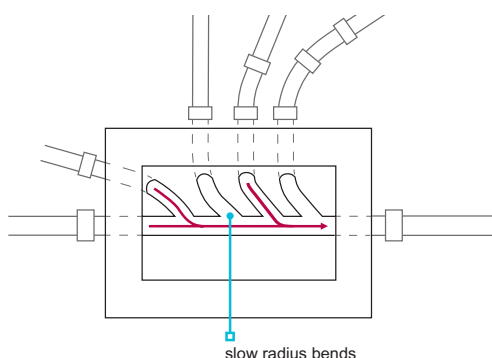

Traditional construction

The minimum specification for traditional manholes and inspection chambers is as follows:

Base	Minimum 100mm concrete
Walls	Brick, blockwork or concrete should be appropriate for the ground conditions 100mm minimum thickness is suitable for depths up to 0.9m where no vehicular traffic loads are encountered and there is no ground water pressure Elsewhere, 200mm minimum thickness should be provided
Rendering	Where required, rendering should be applied to the external faces of the wall
Benching	Benching should be steel trowelled to provide: <ul style="list-style-type: none"> • a smooth finish • rounded corners • a fall of not less than 1:12

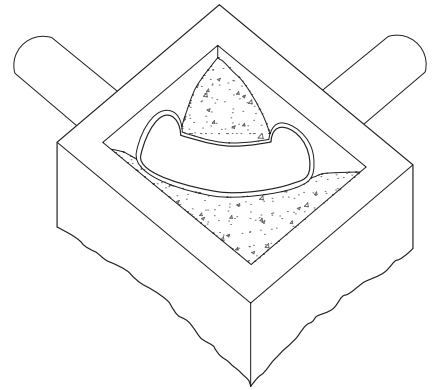

Clay bricks for manholes should comply with BS EN 771 and:

- be of low active soluble salt content
- have a minimum compressive strength of 48N/mm².

Engineering bricks are also suitable.

Concrete bricks for manholes should:

- comply with BS EN 771
- have a minimum crushing strength of 48N/mm² with a minimum cement content of 350kg/m³ for foul drainage.

Calcium silicate bricks should comprise strength class 20 or above for foul drainage situations.

Proprietary systems

Proprietary systems should be:

- in accordance with Technical Requirement R3
- installed in accordance with manufacturers' instructions.

Proprietary manholes should not be used at a depth greater than the manufacturer's instructions.

Adaptors, couplers and sealing rings should be:

- installed correctly and in accordance with the manufacturer's instructions
- treated using the lubricants and solvents specified.

Drainage covers and gully grids

Manhole covers and gully grids should be of the correct type for the proposed location in accordance with Tables 5 and 5a.

Manhole covers used within buildings should be airtight and mechanically secured. Covers used for septic tanks, cesspits and settlement tanks should be lockable.

Manholes should be constructed or installed at the correct level so that the covers will align with the adjacent ground.

Gullies should be adequately:

- bedded
- square and kerbed.
- set level

Table 5: Type of covering and grid required for inspection and manhole covers and frames

Group 1	Areas which can only be used by pedestrians and cyclists
Group 2	Footways, pedestrian areas and comparable areas, car parks or car parking decks
Group 3	For gully tops installed in the area of kerbside channels of roads which when measured from the kerb edge, extend a maximum of 0.5m into the carriageway and a maximum of 0.2m into the footway
Group 4	Carriageways of roads, including pedestrian streets, hard shoulders and parking areas, and suitable for all types of road vehicles

Proprietary items, eg covers to plastic manholes, should be in accordance with manufacturers' recommendations.

Table 5a: Gully grids in carriageways

Grade B	For use in carriageways of roads with cars and slow-moving normal commercial vehicles
Grade A class 2	For use in carriageways of roads
Grade A class 1	For use in carriageways of roads (gully grids of permanent non-rock design)

Ground water

Foul and surface water drainage systems should prevent the ingress of ground water.

Flooding

Where there is a risk of flooding, the advice of the relevant river authority should be followed.

5.3.8 Durability

Also see: Chapter 3.1 and 6.1

Drainage systems shall be adequately durable and protected against damage. Issues to be taken into account include:

- | | |
|--|--|
| a) loads from foundations | d) drainage under buildings |
| b) bedding of pipes | e) chemicals in ground and ground water. |
| c) loads from overlying fill and traffic | |

Loads from foundations

Drains should be located so that foundation loads are not transmitted to pipes. Where drainage trenches are near foundations:

- foundation bottoms should be lower than adjacent trenches, or
- the drain should be re-routed to increase separation.

Where the bottom of a drainage trench is below foundation level, the trench should be filled with concrete to a suitable level.

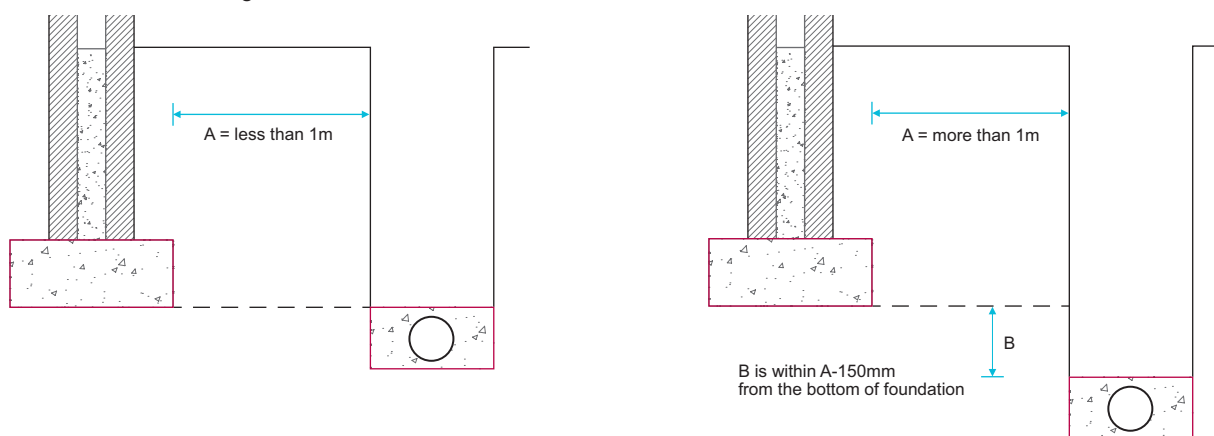

Bedding of pipes

Bedding should be in accordance with Clause 5.3.15.

Loads from overlying fill and traffic

Special protection may be required where pipes are near the ground surface or where they could be damaged by the weight of backfill or traffic load from above.

For flexible pipes, and where greater safety is needed, the bedding class and grading of backfill should comply with BS EN 13242, BS EN 1610 and BS EN 752.

When using proprietary systems assessed in accordance with Technical Requirement R3, pipes should be supported accordingly.

Drainage under buildings

Pipework support should take account of the ground conditions and ensure that the drainage is not adversely affected by ground movement.

Pipework under suspended floors should not be supported on ground or fill that is susceptible to movement without adequate provision being made to:

- maintain minimum design gradients
- protect against backfall
- protect against leakage.

Where drains are located beneath raft foundations or where ground movement is likely, the design of the pipework and support system should be carried out by a suitably qualified engineer in accordance with Technical Requirement R5.

See Clause 5.3.14 for 'Pipework passing through substructure walls'.

Chemicals in ground and ground water

Where the ground or ground water contains sulfates, concrete and masonry work may require special precautions.

5.3.9 Septic tanks and cesspools

Septic tanks and cesspools shall be correctly installed and be suitable for their intended use. Issues to be taken into account include:

- | | |
|---------------------------|---|
| a) capacity | c) permeability of septic tanks and cesspools |
| b) access and ventilation | d) connections to septic tanks and cesspools. |

A septic tank is a form of treatment plant and requires a suitable outfall for treated effluent discharge, which is agreed with the relevant authority.

A cesspool is a tank which stores effluent and has to be emptied periodically.

Capacity

The capacity of the septic tank should be based on the number of people it will serve, using the formula: $C = 180P + 2000$

C = Capacity of tank in litres. Minimum 2700L.

P = Design population/potential occupancy. Minimum four occupants.

Cesspools are required to be at least 18m³ capacity per two users (plus another 6.8m³ per each extra user). A 45-day holding capacity calculated at 150 litres/head/day should be provided.

Access and ventilation

Septic tanks and cesspools should:

- be covered and ventilated
- be provided with access points for inspection, emptying, de-sludging and cleaning
- have the access points with lockable covers and no dimension less than 600mm.

The inlet and outlet of a septic tank should be provided with access for inspection. The inlet of a cesspool should be provided with access for inspection. Cesspools should have no openings except the inlet, the vent and the inspection access.

Permeability of septic tanks and cesspools

Septic tanks and cesspools should be impermeable to their contents and to subsoil water. They should be constructed of brickwork, concrete, glass reinforced concrete, glass reinforced plastics or steel.

Brickwork should be of engineering bricks, laid in cement mortar at least 220mm thick. In-situ concrete should be at least 150mm thick.

Connections to septic tanks and cesspools

The entry flow velocity should be restricted to reduce disturbance in the tank. Where the drain into the septic tank is less than 150mm in diameter; it should have a gradient no steeper than 1:50 for at least 12m.

Rodding and cleaning facilities should be provided at the connection with the tank.

5.3.10 Septic tank outputs

Also see: BS 6297

Septic tanks shall have suitable drainage connections. Issues to be taken into account include:

- a) outfall
- b) flow velocity
- c) soakaways for septic tanks
- d) field drains
- e) underdrains.

Outfall

The designer should ensure at an early stage that consent for discharge will be given, or select an alternative method of drainage. Certain locations and ground conditions may preclude the use of proprietary septic tanks. Septic tank sewage systems should have:

- satisfactory outfall disposal
- placement that accounts for topography and ensures that water is drained away from the building.

Where a septic tank drainage system is to be installed, NHBC requires:

- evidence of a satisfactory percolation test
- copies of relevant consents and approvals before work commences.

Flow velocity

A dip pipe should be provided with:

- the top limb rising above scum level, and
- the bottom limb extending about 450mm below top water level.

Soakaways for septic tanks

Soakaways in porous subsoils

A soakaway may be used where the outfall from a proprietary septic tank is to discharge to a porous subsoil at a level above that of the winter water table. Soakaway constructions generally consist of an excavation filled with brick bats or other large pieces of inert material, or unfilled but lined, eg with dry laid brickwork or precast concrete (porous or perforated) rings, from which the effluent may percolate into the surrounding ground. Proprietary septic tanks should be assessed in accordance with Technical Requirement R3.

Soakaways which are not filled should be covered by a slab incorporating an inspection cover.

The size of the soakaway should be determined as described in this chapter and the area of the bottom of the soakaway should equal the area of trench bottom in Chart 1 below.

Where the porous strata is overlaid by less permeable subsoil, a borehole may be permitted by the appropriate authority on obtaining a discharge consent.

Where soakaways are to be used, the use of tertiary treatment unit may be required to minimise the amount of suspended solids in the treated wastewater and use of grease trap to part cleanse kitchen wastewater, upstream of a packaged treatment plant may also be necessary to minimise the risk of fat clogging up the soakaway system.

Where a geotextile wrapped cellular soakaway is the desired outfall for a single unit treatment plant or a proprietary septic tank, it should be designed for the discharge from the treatment plant to flow via silt trapped chamber before entering the soakaway. The chamber should be regularly maintained (together with the treatment plant) to ensure suspended particles discharge into the soakaway are minimised.

Soakaways in less porous subsoils

In less porous subsoils, a sub-surface irrigation system may be used, which should be designed:

- using approved means to determine the percolation rate
- according to the area of sub-surface drainage from which the length of land drain can be found, determined by the following procedure.

Percolation test procedure for septic tanks:

Step 1	Excavate a hole 300mm square and 250mm deep below the proposed invert level of the land drain
Step 2	Fill with water to depth of 250mm. As an aid, mark a stick 250mm from one end, place in the hole and fill to the mark. Allow the water to drain away overnight
Step 3	Refill to a depth of at least 250mm and note the time taken (in seconds) to drain away completely
Step 4	Repeat the exercise two more times and calculate the average of the three results, as follows: $\text{percolation value (s)} = \frac{\text{time to drain away (seconds)}}{\text{depth of water (mm)}}$

The results of the percolation test should be used in accordance with Table 6 to determine a suitable method of drainage.

Table 6: Suitable methods of drainage

Percolation value (s)	Suitability for less porous subsoils
Up to 100	Chart 1 to determine the field drain trench area Chart 2 to determine the pipe length to provide this area
100 to 140	As above, but underdrains are also necessary
Over 140	The soil is unsuitable for field drains

Table 7: Capacity based on potential occupancy

Number of persons/bed spaces	Minimum capacity (litres)
< 4	2700
4	2720
5	2900
6	3080
7	3260
8	3440
9	3620
10	3800

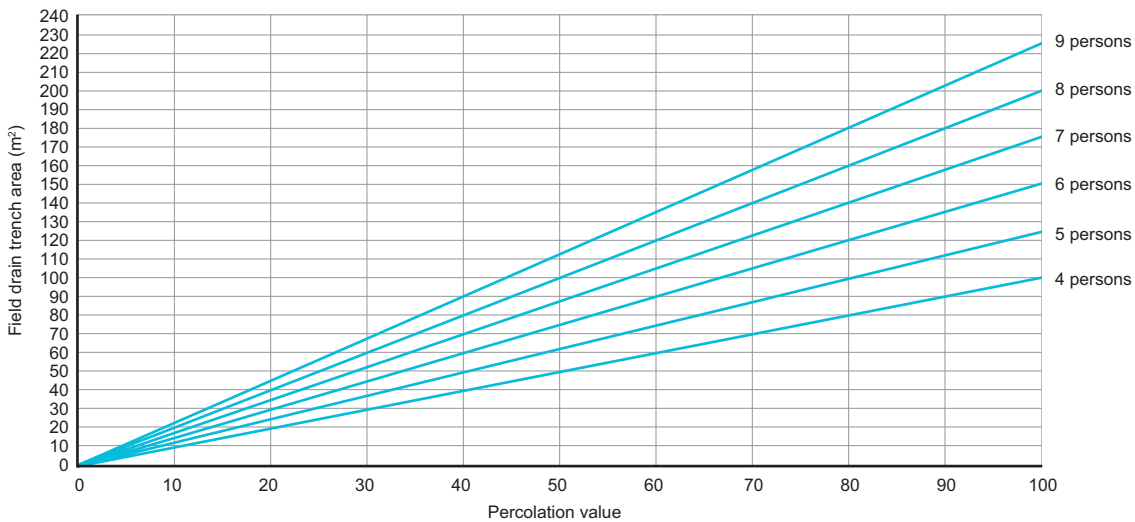
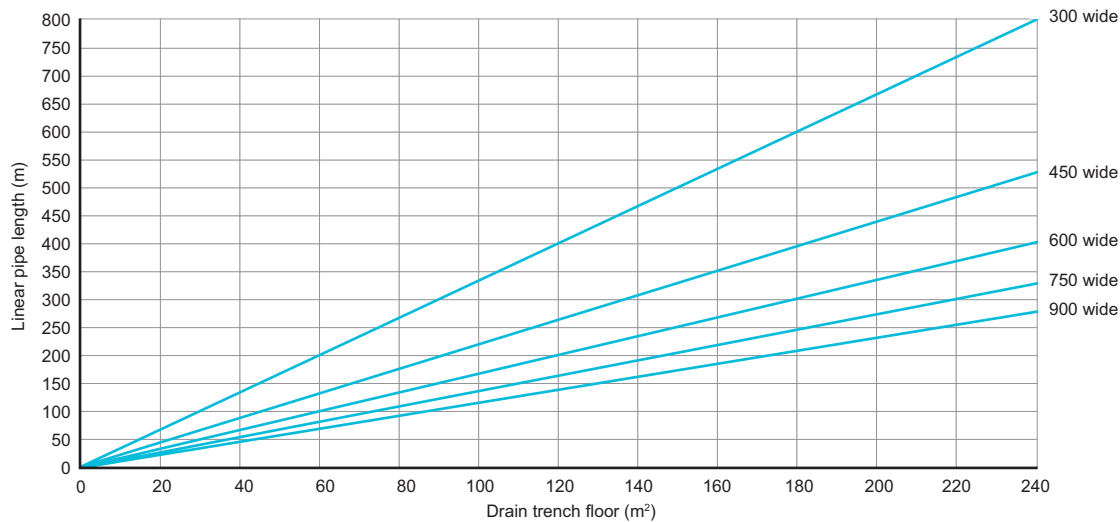
Chart 1: Field drains trench area**Chart 2:** Field pipe length

Field drains

Field drains should be:

- sited according to topography, ensuring that water is drained away from the building
- formed with perforated pipe, laid at least 500mm below the surface
- laid in trenches with a uniform gradient less than 1:200 with undisturbed ground 2m wide between trenches and at least 8m from any building and 10m from any water course
- laid on a 150mm bed of clinker, clean gravel or broken stone (20mm–50mm grade) and trenches filled to a level 50mm above the pipe and covered with strips of plastic material to prevent entry of silt
- backfilled with as dug material.

Where the level of the water table is expected to rise in the winter months to within 1m of the field drain invert, it is not acceptable to use subsurface irrigation.

Underdrains

Where underdrains are necessary, drainage trenches should be constructed a minimum of 600mm deeper than the pipe level specified in the design.

The lower part of the drainage trenches should be filled with pea gravel. A second system of drainage pipes should be laid on the bottom of the trenches to convey surplus drainage to an outfall in a surface ditch or watercourse.

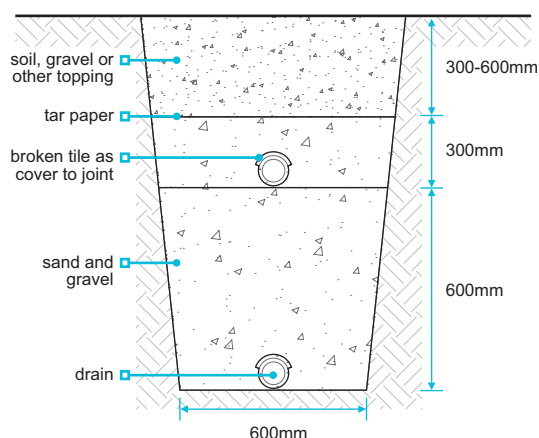

5.3.11 Surface water soakaways

Also see: BRE Digest 365

Soakaway drainage shall be sited and constructed to provide adequate short term storage for surface water and adequate percolation into the surrounding ground. Issues to be taken into account include:

- a) soakaway location
- b) soakaway design.

Soakaway location

Soakaways should be:

- built on land lower than, or sloping away from, buildings
- sited at least 5m from the foundations of a building
- sited to take account of topography, ensuring that water is drained away from the building
- in soil of low permeability, only be provided where no alternative system is available.

Soakaway design

NHBC will require a percolation test for a soakaway, especially where there is:

- doubt about the ground,
- a large quantity of run-off into the soakaway which may swamp the ground.

Where the ground is free draining and granular, a test may not be necessary.

In soil, chalk and fill material subject to modification or instability, the advice of a specialist geotechnologist should be sought regarding the siting and suitability of soakaways.

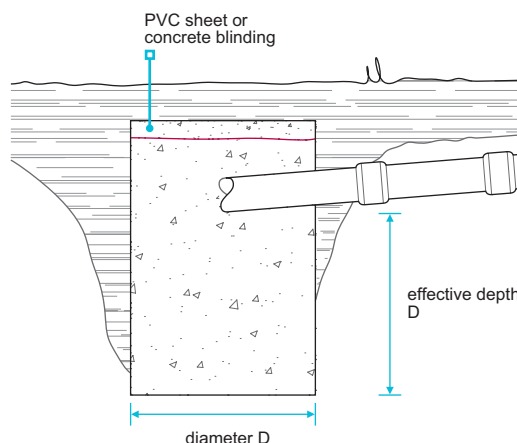

Small soakaways

Small soakaways are holes filled with granular material, eg broken brick, crushed rock or gravel, with particle size 10mm to 150mm.

PVC sheet or concrete blinding should be laid over the fill to prevent topsoil being washed down into the soakaway.

Large soakaways

Large soakaways consist of a pit lined with dry jointed or honeycomb brickwork.

Alternatively, precast perforated concrete rings or segments may be laid dry and surrounded with granular material.

Large soakaways should be designed in accordance with BRE Digest 365, and the volume calculated to ensure suitable capacity including checking appropriate time to emptying half the storage volume.

Percolation test procedure for small surface water soakaway

The rate at which water will disperse into the ground depends on the permeability of the ground, which varies with soil type. The percolation test provides an assessment of how the ground drains.

The following test procedure and design approach may be adopted where the soakaway is for a single dwelling development with a total drained area of less than 100m².

As the test hole can be used as part of a soakaway, it should be:

- dug in a place that could be used as a soakaway
- to the same depth as the proposed drain.
- at least 5m from the foundations of a building

Percolation test procedure for surface water soakaways

Step 1	Bore a hole 150mm in diameter with an auger, to a depth of one metre
Step 2	Fill with water to depth of 300mm. As an aid, mark a stick 300mm from one end, place in the hole and fill up to the mark. It takes approximately 5.5 litres to fill a volume of this size
Step 3	Observe the time taken in minutes for the water to soak away
Step 4	Where possible, the test should be repeated and the average time used
Step 5	A second group of tests are carried out after the hole has been bored out to a depth of two metres, still using a 300mm depth of water
Step 6	Where the soil appears to become more permeable with depth, it may be useful to deepen and retest the bore in one-metre stages

Design of soakaway

The relationship between the diameter or effective depth required for a soakaway, to suit a given collection area, eg roof or paved surface, and the average time (T) resulting from the test is shown in the graph below.

The diameter and effective depth below invert level are assumed to be the same dimension (D).

Example

Test time (T) = 900 minutes

Plan area to drain = 150m²

From the graph below, the diameter and effective depth of the soakaway (D) are both 2.8m.

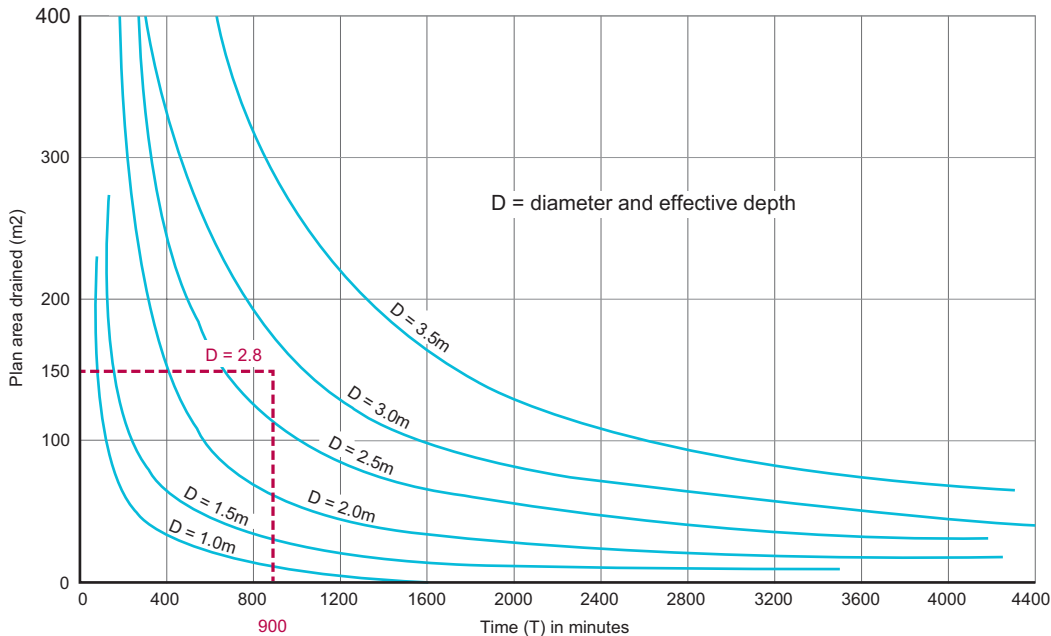

Where the ground is of low permeability; dig separate soakaways to drain smaller but distinct parts, for example:

- one side of a roof to one soakaway
- the driveway or yard to a third soakaway.
- the other side to a second soakaway

Where the permeability of the ground increases with depth; tests in the deepened trial holes will give shorter percolation times. It may be more cost effective to build a smaller soakaway at a greater depth below the surface.

5.3.12 Component requirements

Drainage systems shall be constructed with materials that ensure satisfactory service over the life of the system.

Components in accordance with the following standards will generally be acceptable:

BS 65	'Specification for vitrified clay pipes, fittings and ducts, also flexible mechanical joints for use solely with surface water pipes and fittings'
BS 437	'Specification for cast iron drain pipes, fittings and their joints for socketed and socketless systems'
BS 4660	'Thermoplastics ancillary fittings of nominal sizes 110 and 160 for below ground gravity drainage and sewerage'
BS 4962	'Specification for plastics pipes and fittings for use as subsoil field drains'
BS 5911	'Precast concrete pipes, fittings and ancillary products'
BS EN 124	'Gully tops and manhole tops for vehicular and pedestrian areas'
BS EN 295	'Vitrified clay pipe systems for drains and sewers'
BS EN 476	'General requirements for components used in drains and sewers'
BS EN 588	'Fibre cement pipes for sewers and drains'
BS EN 877	'Cast iron pipes and fittings, their joints and accessories for the evacuation of water from buildings. Requirements, test methods and quality assurance'
BS EN 1401-1	'Plastics piping systems for non-pressure underground drainage and sewerage – Unplasticised poly (vinyl chloride) (PVC-U)'
BS EN 1916	'Concrete pipes and fittings, unreinforced, steel fibre and reinforced'
BS EN 12566-1	'Small wastewater treatment systems for up to 50 PT. Part 1: Prefabricated septic tanks'
BS EN 13101	'Steps for underground man entry chambers. Requirements, marking, testing and evaluation of conformity'
BS EN 13476	'Plastic piping systems for non-pressure underground drainage and sewerage. Structured wall piping systems of unplasticized poly (vinyl chloride) (PVC-U), polypropylene (PP) and polyethylene (PE). Parts 1, 2 & 3.'
BS EN 13598-1	'Plastics piping systems for non-pressure underground drainage and sewerage. Unplasticized poly (vinyl chloride) (PVC-U), polypropylene (PP) and polyethylene (PE). Specifications for ancillary fittings including shallow inspection chambers'
BS EN 13598-2	'Plastics piping systems for non-pressure underground drainage and sewerage. Unplasticized poly (vinyl chloride) (PVC-U), polypropylene (PP) and polyethylene (PE). Part 2: Specifications for manholes and inspection chambers'

5.3.13 Excavation

Excavations shall ensure that the invert levels and gradients required by the design are achieved. Issues to be taken into account include:

- | | |
|---------------------------|-----------------------|
| a) setting out dimensions | c) width of trenches. |
| b) depth of trenches | |

Setting out dimensions

When setting out:

- discrepancies in dimensions, and ground conditions which require design modification, should be reported to the designer
- drain runs and depths should be set out from benchmarks previously checked and verified
- resulting variations should be recorded and distributed to all concerned.

Depth of trenches

Excavate to the depths specified in the design.

Where any trench is excavated lower than the designed bottom level, it should be refilled to the designed level.

Fill material should be:

- granular material, or
- concrete mix GEN1 or ST ½, (not for field drains).

Hard spots should be undercut and removed so that local stress points under pipes are avoided. Soft spots should be filled with suitable well-compacted material.

Width of trenches

Trenches should be as narrow as possible within working limits and allow a minimum 150mm working space on each side of the pipe.

5.3.14 Protection of pipework

Also see: Chapter 4.3 and 5.1

Drainage systems shall have pipework adequately protected against damage. Issues to be taken into account include:

- | | |
|---|---------------------|
| a) pipes passing through substructure walls | c) movement joints. |
| b) pipework under finishes | |

Pipes passing through substructure walls

Where drains pass through structural elements; allowance should be made to accommodate movement.

Pipes passing through substructure walls should accommodate movement by:

- a 50mm clearance all round
- a sleeve, with 50mm clearance all round and suitably sealed, or
- bedded pipes, connected on both sides of the wall with flexible joints located as close as is feasible to the outside face of the wall but at a maximum of 150mm from the face of the wall.

Flexible joints should be made in accordance with the pipe manufacturer's recommendations.

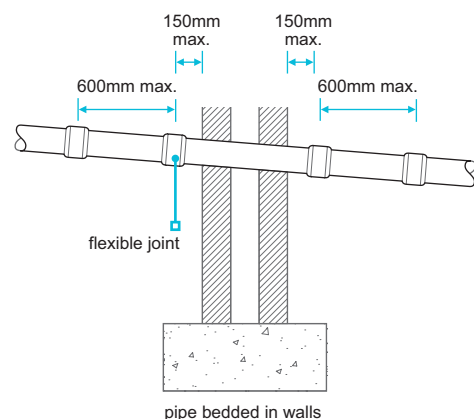
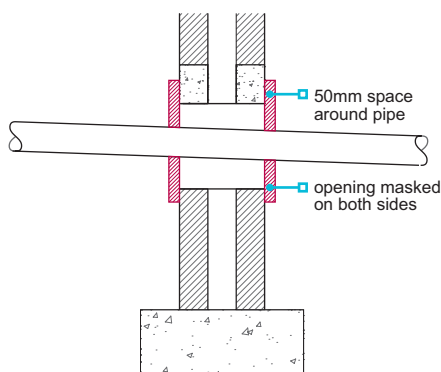

Pipework under finishes

Where drains pass under roads and drives, the final compaction should be sufficient to prevent later settlement.

Rigid pipes less than 1.2m below road surface	Should have: <ul style="list-style-type: none"> • where necessary, a minimum 100mm concrete encasement • movement joints formed with compressible board at each socket or sleeve joint face • flexible joints which remain flexible.
Flexible pipes less than 0.9m below road surface	Should be protected by: <ul style="list-style-type: none"> • concrete bridging slabs, or • surrounded with concrete reinforced as appropriate
Garden areas	Where flexible pipes are not under a road and have less than 600mm cover, where necessary they should have: <ul style="list-style-type: none"> • concrete paving slabs laid as bridging above the pipes, and • a minimum 75mm of granular material between the top of the pipe and underside of the slabs

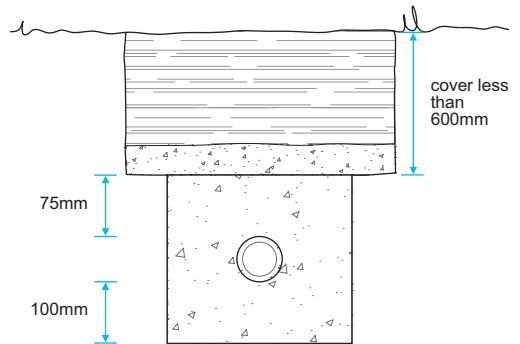

Movement joints

Where rigid pipes are to be encased in concrete, movement joints should be:

- provided around the spigot next to the socket either at 5m maximum intervals or at each joint
- 13mm thick compressible board.

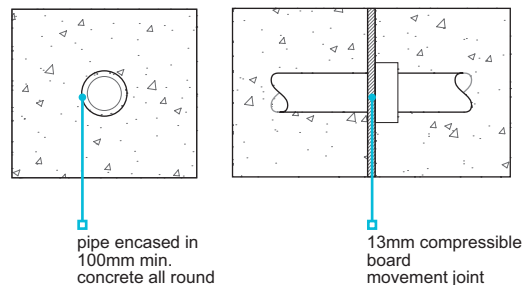

5.3.15 Laying pipework

Pipework shall be laid to the designed lines and gradients. Issues to be taken into account include:

- a) bedding b) sidefill and backfill.

Bedding

Pipes should be firmly supported throughout their length and bedded as specified in the design to resist loads from overlying fill and traffic.

Where pipework is installed under a suspended floor and is supported on ground or fill where movement is likely to occur, additional provisions may be required. See Clause 5.3.8.

Bricks, blocks or other hard material should not be used as temporary supports to achieve the correct gradients, as they may create hard spots which can distort the completed pipe run.

Pipes should be either:

- bedded on granular material, minimum 100mm deep, or
- laid directly on the trench bottom, where the trench bottom can be accurately hand trimmed with a shovel but is not so soft that it puddles when walked on.

For 150mm diameter and 100mm diameter drains, a bed and surround granular material like pea gravel in accordance with Table 8 (to a thickness of 100mm all round the drain) will be acceptable for drains under gardens, paths and drives.

Proprietary systems should be assessed in accordance with Technical Requirement R3 and supported in accordance with the manufacturer's recommendations. Some proprietary systems permit a minimum of 50mm depth of bedding in certain circumstances.

Depressions should be formed where necessary in the trench bottom to accommodate pipe joints.

Pipe bedding, including the bedding material, should be in accordance with:

- BS EN 13242
- BS EN 1610
- BS EN 752.

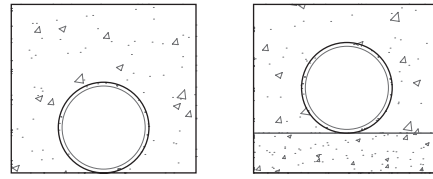

Bedding material and specification should be in accordance with Table 8. Backfill and bedding that includes recycled or secondary materials should conform to the appropriate regulatory requirements for waste, as defined in the Waste Framework Directive 2008.

Table 8: Bedding size

Nominal pipe size	Bedding material complying with BS EN 13242
110mm flexible pipes 100mm rigid pipes	4/10mm pipe bedding gravel
160mm flexible pipes 150mm rigid pipes	2/14mm pipe bedding gravel

Sidefill and backfill

Sidefill and backfill should be placed as soon as the pipes have been bedded, jointed and inspected.

Sidefill should be either granular material or selected backfill material from the trench excavation, free from:

- stones larger than 40mm
- clay lumps larger than 100mm
- timber
- frozen material
- vegetable matter.

Backfill should be well compacted and placed in layers no deeper than 300mm. Mechanical compacting should only be used when compacted backfill is over 450mm above the crown of the pipe.

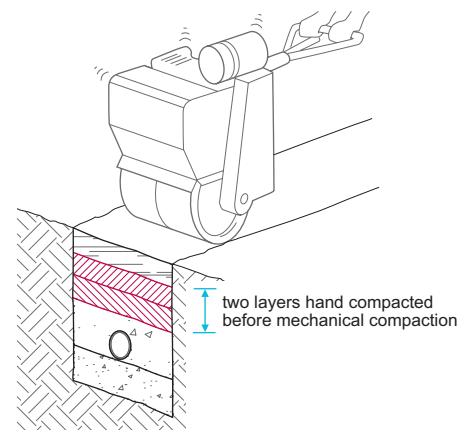
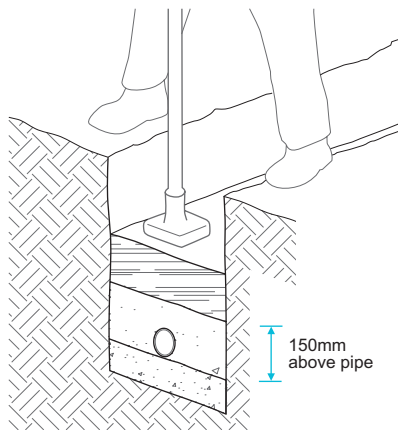

5.3.16 Protection of work

Drainage systems shall be suitably protected from damage by construction work.

Damaged drainage will not be accepted, and it is recommended that:

- no heavy loading or underground work is permitted above, or near, unprotected drainage
- dumpers, trucks, fork lifts or other heavy vehicles are not driven along, or near, pipe runs.

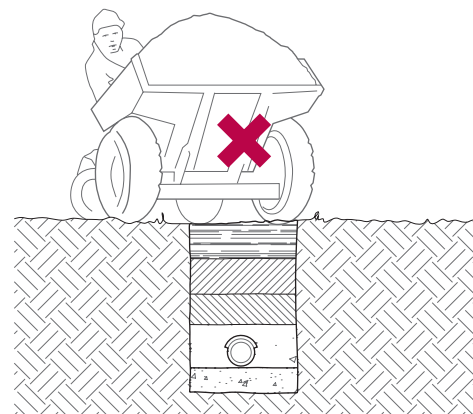

5.3.17 Testing

All foul and surface water drainage systems shall be adequately watertight, and tested where appropriate.

Inspection and testing should be arranged when required by:

- the local authority
- the sewerage undertaker
- NHBC.

Before backfilling, visual inspections are required and the builder is advised to test. When the home is handed over, the system must be in full working order and free from obstruction.



Chapter 5.4



Waterproofing of basements and other below ground structures

This chapter gives guidance on meeting the Technical Requirements for the waterproofing of basements and other structures below, or near to, ground level.

5.4.1	Compliance	02
5.4.2	Provision of information	02
5.4.3	Waterproofing	03
5.4.4	Ground conditions	03
5.4.5	Structural stability	04
5.4.6	Design considerations	04
5.4.7	Waterproofing systems	06
5.4.8	Handling, storage and protection	09
5.4.9	Buried podiums	10

For figure reference tables in this chapter, please go to the end of the chapter



Introduction

This chapter includes guidance for walls, floors and foundations below, or near to, ground level that are intended to prevent the passage of water from the ground (including from sources such as run-off, burst pipes etc) entering the building near to or below ground level.

Guidance for the following types of waterproofing systems is included in this chapter:

- Type A waterproofing barriers
- Type B structurally integral construction
- Type C drained cavity construction.

Constructions that are at risk of coming into contact with water and generally require waterproofing include:

- basements
- semi-basements
- below ground parking areas
- lift pits
- cellars
- storage or plant rooms
- service ducts, or similar, that are connected to the below ground structure
- stepped floor slabs where the retained ground is greater than 150mm.

Types of construction that, depending on the findings of a risk assessment, may require waterproofing include:

- external walls where the lowest finished floor level is less than 150mm higher than the external ground level
- voids caused by split levels.

Typical examples of construction types:

- Waterproofing should be provided where due to the construction details and the ground conditions, there is a risk of contact with ground water (see Table 1)
- _____ Waterproofing is required

Figure 1: Basement

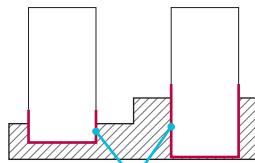

The external ground is raised above the internal floor for the perimeter of the building

depth varies

Figure 2: Retained ground and semi-basement

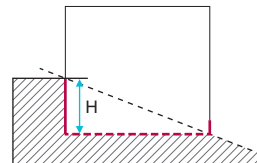

H = any point where the ground is above the finished floor level

Figure 3: Lift pit

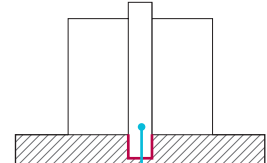

lift

Figure 4: Stairs adjacent to the structure

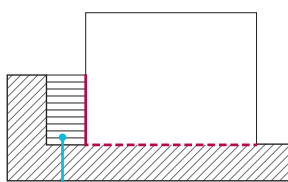

stairs

Figure 5: Stepped floor slabs where the retained ground is greater than 150mm

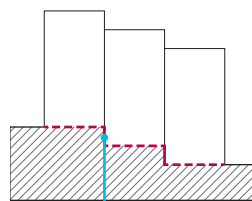

waterproofing required to walls where retained ground is greater than 150mm

Figure 6: Raised external ground levels

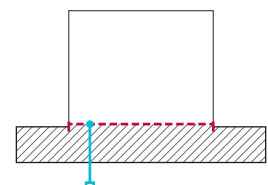

waterproofing required to walls and/or floors where there is a risk of contact with ground water

Figure 7: Buried podium

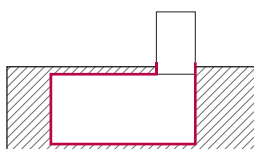
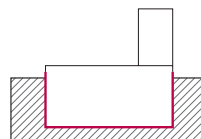

Figure 8: Raised podium



The below ground waterproofing must have continuity with waterproofing to the raised podium that itself should have continuity with the superstructure damp proofing. Also see Chapter 7.1 'Flat roofs and balconies'.

Figure 9: Retaining walls forming lightwells

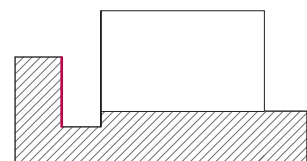
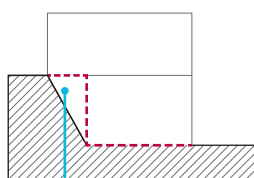

Figure 10: Split levels



structures adjacent to voids where water may accumulate

Definitions for this chapter

For the purposes of this chapter the following definitions apply:

Cavity drain membrane	Semi-flexible sheet designed to form a cavity that intercepts water penetrating the structure and directs it to a suitable drainage point See Type C drained cavity construction
Combined system	For the purposes of this chapter, a combined system includes: <ul style="list-style-type: none"> • Type A and Type B • Type A and Type C • Type B and Type C It does not include Type A and Type A of different performance characteristics as recognised in BS 8102
Ground barrier	A barrier used to resist the ingress of moisture and/or hazardous gases into the building
Lowest finished floor level	The top surface of the lowest finished floor, including lift pit floors, car park surfaces and other similar surfaces Excluding coverings such as carpet and tiles
Retained ground	In this chapter retained ground levels are taken from the top of the retained ground to the lowest finished floor level
Type A fully bonded barrier	Type A barrier that forms part of a composite structural wall, including liquid applied and cementitious systems Typically, when membranes, they will prevent water from tracking from a defect in the membrane to a crack/joint in the structure Post-applied sheet membranes are not considered to be fully bonded barriers for the purposes of this chapter
Type A post applied membrane	A sheet membrane applied to the completed structure typically with hot or cold adhesive
Type A waterproofing barrier	A waterproofing barrier applied to the structural element being waterproofed, also known as tanking
Type B structurally integral construction	Where the water-resistant properties of the retaining structure provide waterproofing to the building This chapter provides specific guidance for the use of Type B concrete systems cast in-situ, with or without water resisting admixtures. The principles are applicable to other Type B systems listed in BS 8102
Type C drained cavity construction	Construction that incorporates a cavity, generally formed with a cavity drain membrane Water is removed from the cavity via a managed drainage system
Waterproofing design specialist	A suitably qualified person co-ordinating the team involved in the design of waterproofing to basements and other below ground structures
Waterproofing system	A fully assessed and certified system of compatible materials and components used to provide waterproofing. These are normally considered to be Type A, B or C as defined above

Also see: Chapter 2.1, BS 8102 and The Basement Information Centre 'Guidance Document - Basements for Dwellings' and 'Basements: Ground Gases and Structural Waterproofing'

5.4.1 Compliance

Basements and other below ground structures shall comply with the Technical Requirements.

Waterproofing of basements and other below ground structures, including foundations, walls and floors that complies with the guidance in this chapter will generally be acceptable.

5.4.2 Provision of information

Designs and specifications shall be produced in a clearly understandable format, include all relevant information and be distributed to all appropriate personnel.

Design and specification information should be issued to site supervisors, relevant specialist subcontractors and/or suppliers and include the following information:

- a full set of current drawings
- details of joints, junctions and service penetrations.
Complex details should be considered and presented in three dimensions
- the manufacturer's information, including relevant parts of the system design manual
- an installation method statement detailing the sequence of works
- a ground condition report
- third-party certifications
- details of the waterproofing design specialist.

Design and specification information should be provided to NHBC at least eight weeks in advance of the works starting on site, in accordance with NHBC Rules.

5.4.3 Waterproofing

Also see: BS 8102

The design of waterproofing systems shall be undertaken by a suitably qualified person and be appropriate for the specific performance required. Items to be taken into account include:

- a) waterproofing design
- b) risk-based design.

Waterproofing design

Waterproofing systems should be designed by a waterproofing design specialist. Designers who have successfully completed the Certified Surveyor in Structural Waterproofing (CSSW) qualification available from the Property Care Association (PCA) are generally acceptable to NHBC. An alternative demonstration of competence may be acceptable, subject to successful review.

The waterproofing design specialist should be appointed in the early design stages to co-ordinate with other designers, including the engineer, and to ensure satisfactory integration of the waterproofing system.

Risk-based design

Waterproofing should be appropriate to the risk, and generally assume exposure to a full height of water during the design life of the building.

Combined systems should be used where:

- a Grade 3 environment is needed, and
- the wall retains more than 600mm.

Alternatively, where the builder has demonstrated that the water table is permanently below the underside of the lowest floor slab, a Type B structurally integral concrete system is acceptable without further protection from a combined system.

The following Types of waterproofing are acceptable where a Grade 1b environment is needed and more than 600mm of ground is retained:

- Type A fully bonded barrier
- Type B
- Type C
- a combined system.

5.4.4 Ground conditions

Also see: Chapter 4.1

The waterproofing system shall take account of ground conditions.

The ground conditions should be fully considered by the engineer and waterproofing design specialist in the design of the waterproofing system.

NHBC may request investigation and a report of the ground conditions where the below ground waterproofed structure:

- retains more than 600mm of ground, measured from the top of the retained ground to the lowest finished floor level
- comprises more than 15% of the perimeter of an individual building (eg terraced homes, apartment blocks and detached garages), measured on plan.

The ground conditions report should take into account appropriate investigations, as described in Table 1.

Table 1: Investigation of ground conditions

Further investigation	Guidance and information
Desk study, including review of: <ul style="list-style-type: none"> • ground water, lost rivers and flooding issues • flood potential of the site • available ground water data • SuDS impact assessment • flood risk assessment • topography of the site • effects of adjacent surface finishes 	www.environment-agency.gov.uk/homeandleisure/floods www.bgs.ac.uk/geology-projects/groundwater-research/groundwater-data/ www.metoffice.gov.uk/weather/climate/uk-climate climate-change.data.gov.uk Historical Publications Ltd 'The Lost Rivers of London' by Nicholas Barton
Contaminated or aggressive ground and/or ground water conditions	Testing required where there is the potential for chemically aggressive ground and/or ground water
Water level change, including potential for flash flooding and waterlogging	Identifying likely fluctuations and short-term flooding events
Impact assessment of ground water flow where the construction is likely to have a 'damming' effect	Interpretative report by a qualified engineer, hydrologist or hydrogeologist to include: <ul style="list-style-type: none"> • assessment of the direction of ground water flow • damming effects on the ground water regime • damming effect of adjacent structures

Where it is necessary to establish the water table, a detailed hydrogeological assessment should be undertaken by a suitably qualified engineer, and include:

- long-term water level monitoring over at least one year to capture seasonal fluctuations
- short-term flooding events that typically occur during autumn and spring
- information based on a suitable number of boreholes monitored at intervals of three months or less.

5.4.5 Structural stability

Also see: Chapters 4.1, 4.2 and 5.1

Elements forming a waterproofing structure below ground including: foundations, walls and floors, shall adequately resist movement and be suitable for their intended purpose. Issues to be taken into account include:

- | | |
|----------------------|--------------------------|
| a) site conditions | d) movement |
| b) structural design | e) design co-ordination. |
| c) durability | |

Site conditions

Parts of the building constructed below ground level that form the structural elements of usable spaces should be designed by an engineer in accordance with Technical Requirement R5 where they are retaining more than 600mm. Issues that should be taken into account include:

- characteristics of the site
- ground conditions
- hazards.

Structural design

The structure should be designed to take account of all imposed loads and actions, including:

- ground movement
- lateral forces from ground water, retained ground and ground surcharge loads
- buoyancy
- loading from other parts of the building
- temporary loading conditions.

Durability

The structure should be designed to be sufficiently durable against site hazards, including:

- chemicals
- frost action
- cyclical wet-dry conditions.

Movement

Movement within the structure should be limited to the capacity of the waterproofing system's resistance to such movement, ensuring that the designed level of watertightness is achieved. Detailed guidance for the limitation of movement should be provided where appropriate.

Movement joints in below ground waterproofed structures should be avoided. Where it is necessary to provide movement joints, the design should ensure satisfactory in-service performance, including watertightness. Such joints should be accessible for maintenance, and not permanently concealed by other structural elements of the building.

Design co-ordination

Structural design should be co-ordinated with the design of the waterproofing.

5.4.6 Design considerations

Also see: Chapters 5.1, 5.2, 5.3 and 6.3

The waterproofing of all elements, including walls, floors and foundations, forming below ground structures shall be suitable for intended use. Issues to be taken into account include:

- | | |
|--|---|
| a) grade of waterproofing protection | d) joints, abutments and service penetrations |
| b) waterproofing systems, materials and components | e) steps and level changes. |
| c) interface with the above ground structure | |

Grade of waterproofing protection

Waterproofing systems should be designed to resist the passage of water and moisture to internal surfaces.

The waterproofing grade should be appropriate for the proposed use of the internal space and the equipment located within.

Table 2: Waterproofing grades

Grade	Description	Generally required for:
Grade 3	No water ingress or damp areas is acceptable. Ventilation, dehumidification or air conditioning necessary; appropriate for the intended use	Habitable accommodation
Grade 2	No seepage is acceptable. Damp areas as a result of internal air moisture/condensation are tolerable; measures might be required to manage water vapour/condensation	Non-habitable areas, such as car parks, storage or plant rooms where the internal finishes are not readily damaged by moisture (Some water ingress may occur where openings are provided in car parks, eg for ventilation. To minimise potential for standing water, refer to Chapter 9.1 'A consistent approach to finishes'. Car parks should be provided with drainage to a suitable outfall)
Grade 1b	No seepage. Damp areas from internal and external sources are tolerable	
Grade 1a	Seepage and damp areas from internal and external sources are tolerable, where this does not impact on intended use	Retaining walls typically used to form external lightwells (Drainage may be required to deal with seepage)

Where there is doubt about potential use, minimum Grade 3 protection should be considered in the waterproofing design.

Waterproofing systems, materials and components

Components forming the waterproofing system should be predefined and assessed to demonstrate suitable performance.

The assessment should recognise waterproofing may extend or continue across different substrates and/or other materials, products or building systems, or that materials and components may be interchangeable between systems. To ensure performance will be maintained checks should be undertaken on chemical and adhesive compatibility before installation. Manufacturers often have material compatibility data that can be referred to, however undertaking on-site tests prior to full application are recommended to verify predicted suitability. Substrates should be suitably primed, prepared, dried, cured, cleaned of dirt, dust or other debris and/or protected in accordance with manufacturer's instructions throughout the site works.

The design information and documentation should detail waterproofing systems, materials and components in accordance with the manufacturer's recommendations.

Proprietary waterproofing systems, materials and components should be assessed in accordance with Technical Requirement R3.

Interface with the above ground structure

Waterproofing should extend at least 150mm above the external ground level and connect with the superstructure damp proofing. This can generally be achieved by linking the below ground waterproofing system to a continuous cavity tray.

The connection between the below and above ground waterproofing should be bonded and formed with appropriate materials.

Where the waterproofing is linked to the above ground structure via a cavity tray, the materials should:

- compress to form a watertight seal
- be capable of taking the load.

Bitumen-based materials in accordance with BS 6398 or suitable materials assessed in accordance with Technical Requirement R3 should be used.

Joints, abutments and service penetrations

The design of waterproofing systems should include the correct method and detailing to form joints, abutments and service penetrations, including those between:

- the waterproofing system and superstructure damp proofing
- horizontal and vertical waterproofing
- system components.

The manufacturer should confirm compatibility between different materials where they are used to form joints.

Figure 11: Ground level interface

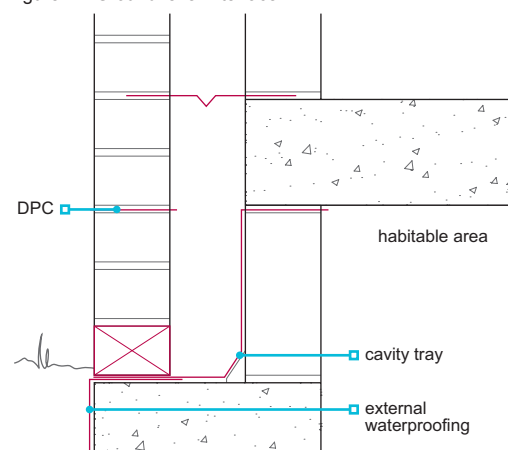

Details of how junctions and abutments are formed should be provided to site personnel. Proprietary components that are part of, or compatible with, the waterproofing system should be used for complex joints, abutments and service penetrations.

Figure 12: Service entry

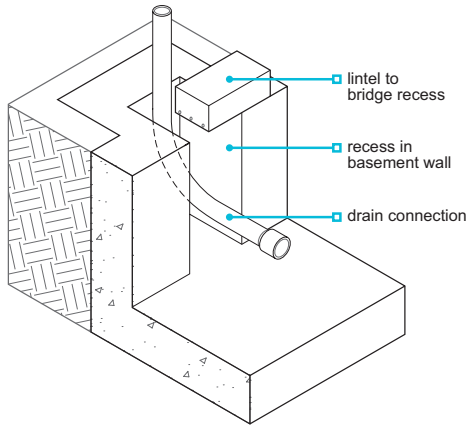

Penetrations through the waterproofing should be avoided where possible. Where penetrations cannot be avoided, the design should detail the method of waterproofing to ensure that it is watertight and durable.

Penetrations, including those for wall ties, services and drainage systems, should:

- be suitably separated to allow for proprietary seals to be correctly installed
- account for differential settlement and movement between the structure/finishes and services.

Steps and level changes

Situations where steps and level changes occur within buildings are not uncommon and it is often necessary to consider where normal damp proofing arrangements are likely to become ineffective, resulting in a need for waterproofing to be applied.

Issues to be taken into account include:

- nature of both the substructure and superstructure constructions and their resistance/susceptibility to liquid water and/or water vapour. For example, use of timber or light gauge steel framed superstructures, requirements for drained and/or vented cavities, ability for timber sole plates to breathe, inclusion of insulation(s)
- height difference between finished floor levels
- height of soil retention and/or presence of voids
- robustness of damp proofing or waterproofing solution(s) proposed
- accessibility for repair
- ground conditions and hydrology
- inclusion of subsurface drainage
- provision and continuity of damp proofing to walls and/or floors, interface with the above ground structure (particularly relevant should hazardous gases be present)
- relationship between internal and external ground levels
- continuation at returns, possibly of a different construction type (for example a change from solid to cavity walls or from concrete to masonry construction). Such situations should be considered in three dimensions.

5.4.7 Waterproofing systems

Also see: Chapters 3.1, 3.2, 4.1, BS 8102 and The Concrete Centre 'Concrete basements Guidance on the design and construction of in-situ concrete basement structures'

The waterproofing shall be suitable for intended use and installed in accordance with the design. Items to be taken into account include:

- a) Type A waterproofing barriers
- b) Type B structure, integral
- c) Type C drained cavity
- d) ancillary components.

Appropriate sequencing of work will enable logical and timely construction of the waterproofing system and prevent unnecessary damage to completed elements of work. Installation should be undertaken in accordance with the design and the installation method statement detailing the sequence of works.

Type A waterproofing barrier

Type A systems generally accepted by NHBC when assessed in accordance with Technical Requirement R3 include:

- post applied membrane (hot or cold adhesive)
- liquid-applied membranes
- geosynthetic (bentonite) clay liners
- mastic asphalt to BS EN 12970
- cementitious systems
- pre-applied fully bonded systems
- proprietary systems or products assessed in accordance with Technical Requirement R3.

Plain polyethylene sheet should not be used as a waterproofing system.

In addition to key characteristics typically declared on product marking or technical literature, when assessing Type A system suitability it could also be important to consider its crack bridging ability and/or resistance to aggressive exposure environments (eg to UV, chemicals or hazardous gases) depending on the system's location, the substrate to which it's applied and the substrate's potential performance under load (eg for there to be cracking, a potential for cracks to generate and for these to be dynamic).

Only fully bonded systems assessed in accordance with Technical Requirement R3 for the specific purpose should be used internally.

Design at junctions and corners should account for proprietary components and be in accordance with the manufacturer's recommendations. Waterproofing barriers should return at corners to prevent water tracking behind.

The substrate to which the Type A system is to be applied should be clean, free from debris and prepared in accordance with the manufacturer's recommendations. Bonded sheet membranes should only be applied directly to masonry substrates that are smooth and have flush pointed joints.

Type A waterproofing should be installed in accordance with the manufacturer's instructions by operatives:

- who are suitably qualified or have been trained by the manufacturer or supplier, and
- who are fully aware of the design and the manufacturer's recommendations for installation.

Completed waterproofing should be protected by:

- protection board, or
- carefully placed backfill material.

The manufacturer's recommendations for climatic conditions at the time of installation should be followed.

Type B structure, integral construction, concrete and application

Structural design should be undertaken by an engineer in accordance with Technical Requirement R5. The design of in-situ Type B concrete systems should be in accordance with:

- BS EN 1992-1-1
- BS EN 1992-3
- Chapter 3.1 'Concrete and its reinforcement'.

Type B systems acceptable to NHBC include:

- in-situ concrete with or without water resisting admixtures and crack widths limited by design
- in-situ high-strength concrete with crack widths limited by design and post-construction crack injections
- precast concrete systems assessed in accordance with Technical Requirement R3.

BS 8102 contains advice on the relationship between tightness classes given in BS EN 1992-3 and grades of performance given in BS 8102 for Grades 1a and 1b. Specialist advice should be sought where other Type B systems are specified.

Ready-mixed concrete should be of sufficient strength and durability, and from a supplier operating under a quality control system acceptable to NHBC such as:

- the Quality Scheme for Ready-Mixed Concrete (QSRMC), or
- the BSI Kitemark scheme.

Other suppliers may be accepted if they operate to a standard acceptable to NHBC.

Figure 13: Type A system

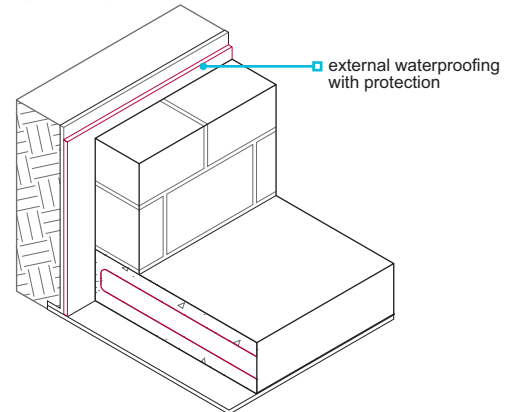
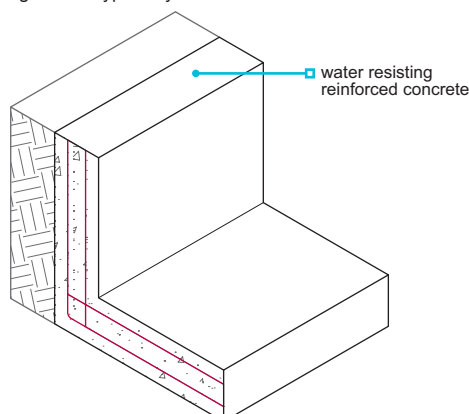

Figure 14: Type B system



The concrete mix should be agreed between the engineer and the waterproofing design specialist, and:

- achieve the necessary robustness, durability and waterproofing
- be suitable for the environmental exposure and ground conditions.

Type B waterproofing should be installed:

- by suitably qualified operatives who are fully aware of the requirements for placing concrete and reinforcement and for installing ancillary components used in Type B systems
- in accordance with the design.

The line, level and position of formwork and reinforcement should be checked prior to concrete placement to ensure that it is in accordance with the design.

Penetrations from tie bars etc should be made good in accordance with the design.

Where joints are formed in concrete, surfaces should be clean and free of excessive laitance. Hydrophilic strips should be protected from water before the joint is formed.

Quality management systems and quality audits should be used to record and monitor the placement of concrete on site. Monitoring records should be supplied to NHBC as requested.

Design details for reinforced concrete structures should include:

- concrete specification
- the type of concrete
- concrete strength
- proportion of any admixture
- proposals for limiting crack widths
- consideration of temporary support to the formwork
- type and position of reinforcement
- the method of making good holes in the concrete formed for shutter bolts and tie bars
- positioning of structural elements
- appropriate tolerances for the line and level of structural elements.

Joints between components, including day work joints, should be durable and made watertight with appropriate waterstops or hydrophilic strips. Kickers cast monolithically as part of the slab should be used to form the joint between floors and walls.

Concrete with admixtures

Where the design of in-situ concrete waterproofing includes admixtures:

- the ratio of admixture to concrete specified in the design should take account of the recommendations of the admixture supplier and requirements of the independent assessment
- the reinforcement should be used to control crack widths, which should be in accordance with the design, but not be greater than 0.3mm max. for flexural cracks and 0.2mm max. for cracks that pass through the section
- suitable quality management systems and quality audits should be used to record and monitor the batching of admixture. This is best achieved by using ready-mixed concrete (see Clause 3.1.5).

Admixtures should be:

- independently assessed, in accordance with Technical Requirement R3
- assessed according to the intended use
- used strictly in accordance with the manufacturer's recommendations and requirements of the independent assessment.

Concrete without admixtures

Where the design of in-situ concrete waterproofing does not include admixtures:

- high-strength concrete may be specified in order to achieve the necessary level of waterproofing, but post-construction crack injection may be required in order to deal with cracking induced by increased thermal and shrinkage strains
- the reinforcement should be used to control crack widths, which should be in accordance with the design, but not be greater than 0.2mm max. for both flexural cracks and for cracks that pass through the section
- a minimum section thickness of 250mm should be used in the design.

Type C drained cavity construction

Type C systems that include a cavity drain membrane which forms a waterproof barrier are acceptable to NHBC when assessed in accordance with Technical Requirement R3. Where a Type C system is formed using a drained masonry cavity wall, the guidance in BS 8102 should be considered. Particular care should be taken if adopting Type C systems on contaminated sites to ensure no pathways are introduced that could present a risk or risks to the end user(s) and/or that systems are suitably chemically resistant; specialist advice should be sought.

Type C systems should be designed to include a drainage system that adequately disposes of water to a suitable outlet, either by gravity or through a sump and pump. The drainage channel, sump and pump should include appropriately located access points for servicing and maintenance. To prevent backflow, the drainage system should be fitted with a one-way valve. Also, in areas which are susceptible to flooding the guidance in BS 8102 concerning inclusion of a flood loop should be considered.

Type C waterproofing should be installed in accordance with the manufacturer's instructions by operatives:

- who are suitably qualified or have been trained by the manufacturer or supplier
- who are fully aware of the design and the manufacturer's recommendations for installation
- using the fixings recommended by the manufacturer.

Pump systems should operate automatically and include:

- a primary pump
- a secondary pump with battery or generator backup
- a suitable audio or visual alarm that indicates pump failure.

Further guidance on multi-level and inverted cavity drain systems can be found in BS 8102.

Figure 15: Type C system

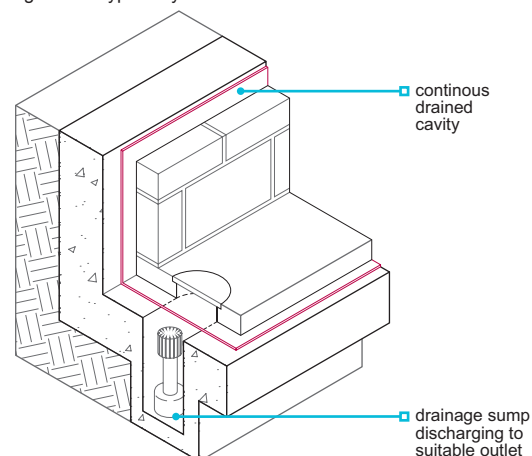
**Ancillary components**

Ancillary components should be assessed as part of the waterproofing system. Alternatively, an assessment of compatibility and satisfactory performance should be provided for materials and products that are interchangeable between different systems.

Ancillary components include:

- preformed junctions and corners
- reinforcement
- waterstops
- hydrophilic strips.

5.4.8 Handling, storage and protection

Waterproofing materials, products and systems shall be handled, stored and protected in a satisfactory manner to prevent damage, distortion, weathering or degradation. Issues to be taken into account include:

a) handling and storage

b) protection from ongoing works.

Handling and storage

Materials, products and systems should be transported, lifted, handled and stored in accordance with the manufacturer's recommendations.

Protection from ongoing works

Design should consider the risk of damage caused by ongoing works. Details of suitable protection measures should be specified in the design and include:

- fixing of other components, such as skirtings, wall ties and wall linings
- protection of the waterproofing from backfilling.

Proprietary products and systems should be protected and tested before backfilling occurs.

5.4.9 Buried podiums

Also see: Chapter 7.1, 10.1, BS 8102 and PCA's Best Practice Guidance 'Podium Decks and Buried Roofs'

Buried podiums shall be protected by adequate waterproofing and drainage.

A buried podium forms a below ground roof to an area of basement that extends beyond the outline of the main building or buildings above. The waterproofing layer must link with damp proofing in any abutting walls. In most cases, the waterproofing should extend to DPC level or a minimum of 150mm above finished external ground level.

The make-up of the waterproofing layer and subsequent toppings that could include sustainable green, biodiverse (brown) or blue roofs, and provisions for drainage, should be co-ordinated at the planning stage. Guidance on the design, detailing and construction of sustainable roof and associated drainage systems (SuDS) is covered in Chapter 7.1.

Provisions should be made to ensure the waterproofing layer and drainage system will not be susceptible to damage or obstruction from tree/vegetation root activity or structural movement. Drainage design should prevent ponding or accumulated/retained water unless part of a proprietary rainwater attenuation system (also see below).

Structural designs should allow for loadings from emergency, maintenance or other vehicular traffic access, mature planting/trees and/or saturated ground, as applicable. Further allowance should be taken of accumulated/retained water where blue roofs are adopted, or it is otherwise predicted by design (but kept to an absolute minimum), for example in the case of a drainage system temporary service fault or blockage prior to overflow provisions, land drainage or another water relieving strategy becoming active.

Figure reference table

Figure reference table 5.4			
Fig No	Title/Description	Clause	Page
Figure 1	Basement	5.4	1
Figure 2	Retained ground and semi-basement	5.4	1
Figure 3	Lift pit	5.4	1
Figure 4	Stairs adjacent to the structure	5.4	1
Figure 5	Stepped floor slabs where the retained ground is greater than 150mm	5.4	1
Figure 6	Raised external ground levels	5.4	1
Figure 7	Buried podium	5.4	1
Figure 8	Raised podium	5.4	1
Figure 9	Retaining walls forming lightwells	5.4	1
Figure 10	Split levels	5.4	1
Figure 11	Ground level interface	5.4.6	5
Figure 12	Service entry	5.4.6	6
Figure 13	Type A system	5.4.7	7
Figure 14	Type B system	5.4.7	8
Figure 15	Type C system	5.4.7	9



Technical Disclaimer

The NHBC Standards are produced by NHBC as guidance solely for our builder customers as to how to interpret the technical requirements in relation to the warranty cover provided by NHBC under its Buildmark, Buildmark Choice, Buildmark Link, Buildmark Solo, Buildmark Connect or any similar product from time to time. It has not been created or intended for distribution or use outside of that purpose. The information contained in the NHBC Standards do not constitute advice and is not to be relied upon by any third party. Nothing in the NHBC Standards is intended to, nor should it be taken to, create any legal or contractual relationship. Any third party who chooses to rely upon the information contained in the NHBC Standards shall do so entirely at their own risk and NHBC accepts no duty of care or liability, however caused, in connection with its use or reliance by any third party.



Standards

2024

NHBC, NHBC House, Davy Avenue, Knowlhill, Milton Keynes, Bucks MK5 8FP

National House-Building Council (NHBC) is authorised by the Prudential Regulation Authority and regulated by the Financial Conduct Authority and the Prudential Regulation Authority in respect of carrying on its insurance business and its insurance distribution activities.

NHBC is registered in England and Wales under company number 00320784. NHBC's registered address is NHBC House, Davy Avenue, Knowlhill, Milton Keynes, Bucks, MK5 8FP. Note that only certain parts of NHBC's products and services are within the scope of UK financial services regulation. For more information on our products and services, please see our website nhbc.co.uk or your NHBC product documentation.