

Land quality – managing ground conditions

This chapter gives guidance on meeting the Technical Requirements for assessing and managing land quality.

4.1.1	Compliance	01
4.1.2	Initial Assessment – desk study (all sites)	03
4.1.3	Initial Assessment – walkover survey (all sites)	04
4.1.4	Initial Assessment – results	04
4.1.5	Basic Investigation (sites where hazards are not identified or suspected)	05
4.1.6	Detailed Investigation (sites where hazards are identified or suspected)	05
4.1.7	Managing the risks (sites where hazards are found)	06
4.1.8	Unforeseen hazards	07
4.1.9	Documentation and verification	07
4.1.10	Guidance for investigations	07
4.1.11	Further information	09

For figure reference tables in this chapter, please go to the end of the chapter



Introduction

This chapter provides a framework for managing geotechnical and contamination risks, with the objective of ensuring that:

- all sites are properly assessed and investigated for potential geotechnical and contamination hazards
- foundations and substructure designs are suitable for the ground conditions
- sites are properly remediated where necessary or appropriate, and design precautions are taken
- appropriate documentation and verification is provided to NHBC.

4.1.1 Compliance

Also see: Chapter 4.2

Assessment of the site and the surrounding area shall comply with the Technical Requirements. Items to be taken into account include:

- a) suitability of persons for the level of investigation
- b) geotechnical and contamination issues
- c) investigation procedures
- d) notification in writing to NHBC of hazardous ground conditions.

Ground investigations and management of risk that complies with the guidance in this chapter will generally be acceptable.

Suitable persons for the level of investigation

The following skills and knowledge are required from the person responsible for the Initial Assessment, Basic Investigation and documentation and verification. They should:

- understand the hazards that can affect the development and where they originate
- recognise the signs of potential hazards
- conduct a desk study and walkover survey
- collect information relating to such hazards on and adjacent to the site
- report the findings in a clear and concise manner
- determine when specialist advice and detailed testing is required.

The following criteria should be used as guidance for the appointment of a consultant or specialist responsible for Detailed Investigation, management of hazards, documentation and verification:

Experience	Similar types of site and development
Appropriate discipline(s)	Understanding of all relevant skills required on the project and access to other disciplines, including geologists, hydrogeologists, toxicologists and environmental chemists
Legislation	Understanding of legislation and liabilities associated with the site
Professional indemnity insurance	Appropriate cover for the work being carried out
Health and safety	Awareness of occupational hygiene issues and Health and Safety legislation
Quality assurance	Use of a quality management system, including appropriately accredited laboratories
Project management	Ability to manage a project team consisting of the appropriate disciplines
Site investigation	Ability to design site investigation programmes, including soil sampling, testing and laboratory analysis
Risk management	Ability to conduct risk assessments as required by the risk management process
Reporting and communication	Ability to prepare comprehensive and well presented reports. Effective communication within their organisation and with the client, statutory authorities and the general public
Engineering design	Understanding of effective risk reduction techniques, eg engineered foundations and substructure details of suitable remediation

Geotechnical and contamination issues

Assessment should be carried out by direct investigation and examination of the ground, supplemented by laboratory testing where necessary, in order to determine the geotechnical and contamination characteristics of the site.

Specifically, where contamination is suspected or found, the site should be assessed using the Source-Pathway-Receptor framework (known as the pollutant linkage).

For land contamination to occur, a source, pathway and receptor must all exist. A written or diagrammatic representation of the land contamination (known as a Conceptual Model), should be produced to show the possible relationships between each.

Procedure

The process to assess and manage the ground conditions is as follows:

Initial Assessment

NHBC requires all sites to be assessed by a desk study and a walkover survey. The results should be used to determine whether or not hazards are known or suspected.

Basic Investigation

Required to support the results of the Initial Assessment where hazards are not suspected.

Detailed Investigation

Required where hazards are known or suspected.

Further Assessment

Required after the Basic or Detailed Investigation has been conducted, to confirm that all objectives have been met. Where results are inconclusive, further investigation will be required.

Hazards

Where hazards are identified, design precautions or remediation will be required to minimise their effects.

If any unforeseen hazards are found during the course of construction, further investigation is likely to be required.

Documentation and verification

NHBC requires documentation and verification to show that:

- the site has been properly assessed and investigated
- where necessary, suitable precautions are incorporated into the design
- all necessary remediation has been carried out.

Notification of potential hazards and associated risks

If a site (defined in the Rules as an area of land that is covered by a single detailed planning consent or series of consents relating to continuous development) is classed as 'hazardous', NHBC must be notified in writing a minimum of eight weeks before work starts. Failure to provide such information may delay the registration process, the construction work and the issuing of NHBC warranty.

Figure 1: Procedure flow chart

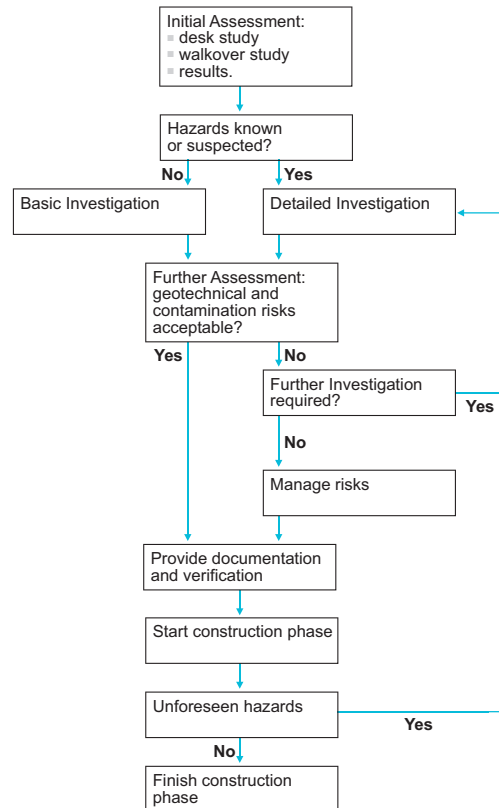

Table 1: Potential hazards and associated risks

Potential hazard	Associated risk
High water table or low-lying land	<ul style="list-style-type: none"> flooding the effects from toxic or noxious materials which could be concentrated or transported by ground water
Mining (past, present and proposed)	<ul style="list-style-type: none"> ground movement as a result of the type of mining and materials extracted ground gasses, including methane and carbon dioxide
Trees and vegetation (eg, Japanese knotweed or Bamboo – ‘running’ type)	<ul style="list-style-type: none"> shrinkage and heave of clay soils physical damage caused by roots
Peat	<ul style="list-style-type: none"> acid attack changes in volume due to variations in moisture content production of methane and carbon dioxide
Infill and made ground, including tipping	<ul style="list-style-type: none"> release of gases which may be explosive or asphyxiating low bearing capacity causing excessive total and/or differential settlements consolidation characteristics which may result in subsidence, settlement and/or excessive tilt localised ground variability (laterally and with depth) which may result in subsidence, settlement and/or excessive tilt collapse compression or inundation settlement of non-cohesive fills which may result in subsidence, settlement and/or excessive tilt
Low bearing capacity ground	<ul style="list-style-type: none"> settlement of foundations and substructures
Former buildings or structures	<ul style="list-style-type: none"> underground obstructions producing variations in bearing capacity and settlement characteristics
Adjacent buildings	<ul style="list-style-type: none"> effect on stability of both new and existing buildings
Drains, including land drains	<ul style="list-style-type: none"> contamination, flooding, waterlogging and interruption of land drainage systems
Sulfates and sulfides in ground or ground water	<ul style="list-style-type: none"> expansive reaction chemical attack on concrete, mortar and bricks or blocks made with cement
Contamination	<ul style="list-style-type: none"> from substances which may be carcinogenic, toxic, asphyxiating, corrosive, phytotoxic, combustible, explosive or radioactive
Solution features in chalk, gypsum and limestone, including swallow holes	<ul style="list-style-type: none"> underground cavities
Unstable ground subject to landslip	<ul style="list-style-type: none"> ground movement
Seas, lakes and rivers adjacent to land	<ul style="list-style-type: none"> erosion exposure to saline

4.1.2 Initial Assessment – desk study (all sites)

A desk study of the site and the surrounding area, that covers key and existing site information, shall be undertaken by a suitable person and include investigation of soils, geology, surface water, ground water, current and historical uses.

A desk study is the collection and examination of existing information obtained from a wide variety of sources. It should indicate potential hazards at an early stage and provide a basis for the investigation. Potential problems should be assessed according to the current and historical uses of the site and surrounding area, including those which may have been left by:

- industrial, commercial and agricultural uses, including storage
- mining
- quarrying
- landfilling and tipping.

Key information sources include:

- the Environment Agency or its equivalent – for example, coastal erosion, landfill sites, details of water abstraction
- the local authority – for example planning and environmental health
- British Geological Survey, maps and information
- Ordnance Survey, current and previous editions of plans and aerial photographs
- Coal Authority, mining reports – past, present and proposed mining
- utility companies
- county records offices, libraries, museums and local history sources
- soil survey maps
- the site vendor
- in-house information
- ongoing monitoring
- the internet.

4.1.3 Initial Assessment – walkover survey (all sites)

To assess ground conditions, a walkover survey of the site and the surrounding area shall be undertaken by a suitable person.

A walkover survey is a direct inspection of the site and the surrounding area carried out in conjunction with the desk study. Indications of any potential hazards should provide a basis for the investigation. A photographic record of the site can help in the reporting of the walkover survey.

Table 2: Potential hazards

Source of information	Items to be taken into account
Topography	<ul style="list-style-type: none"> • abrupt changes in slope • valley bottoms or depressions which may be soft or filled • evidence of overburden on slopes • excavations at the base of the slope • signs of landslip, eg tilting trees, posts or walls • signs of subsidence • evidence of imported soil including local surface depressions, tipped material or rubbish, particularly if it is hot or has an odour
Soils and rocks	<ul style="list-style-type: none"> • the basic ground type • evidence of peat, silt or other highly compressible material at or below the surface • cracking or stickiness of the surface which may indicate a shrinkable sub-soil • sudden changes in conditions, eg clay to chalk or soil to rock
Surface water and vegetation	<ul style="list-style-type: none"> • a high water table indicated, eg by waterlogged ground • signs of flooding • reeds or water-loving plants • springs, ponds, wells, ditches or streams • the source of any discoloured water
Vegetation	<ul style="list-style-type: none"> • vegetation which may indicate the nature of the soils • sparse dead or dying vegetation • type and condition of vegetation on land adjoining the site • species, height and condition of the trees • species, height, spread and condition of hedges and scrub on clay • evidence of former trees, hedges or scrub on clay
Structural information	<ul style="list-style-type: none"> • damage to structures, eg cracking in buildings, on or around the site • other evidence of movement, eg tilting or distortion • any structures or services below ground
Local information	<ul style="list-style-type: none"> • local knowledge of the site, eg mining, refuse tipping or flooding • local industrial history records indicating past and present uses of the site • place names and street names that may give clues to previous site usage, eg Brickfield Cottage, Water Lane, Tin Shop Hill

4.1.4 Initial Assessment – results

Also see: BS 5930

The results of the desk study and walkover survey shall be recorded and evaluated by a suitable person.

Initial results should be evaluated for suspected hazards and the results recorded, and include the following as appropriate:

- site plans, including dates, previous and current uses, and proposed site layout
- geology of the site, including geological maps, previous site investigations and laboratory test results
- photographs, including aerial photographs, showing points of interest or concern (eg areas of ground instability), interpretation of aerial photographs, and dates of photographs
- list of sources of information consulted and copies of the information obtained.

4.1.5 Basic Investigation (sites where hazards are not identified or suspected)*Also see: BS EN 1997-2*

Where hazards are not suspected, a Basic Investigation of the site, including geotechnical and contamination investigations, shall be carried out by a suitable person and recorded to the satisfaction of NHBC.

The Basic Investigation aims to provide assurance for all sites, regardless of how free of hazards they may appear, and forms the minimum requirement for a site investigation.

The number and depth of trial pits should be located so they are representative of the site and will depend upon the:

- proposed development
- nature of the site
- inconsistency of the soil and geology across the site.

Trial pits should be located outside the proposed foundation area, and generally be a minimum of 3m deep. The distance from the edge of the foundation should not be less than the depth of the trial pit. Where trial pits do not provide sufficient information, boreholes will be necessary.

Basic geotechnical and contamination investigations should be conducted and include:

- physical tests, such as plasticity index tests, to support the results of the Initial Assessment
- a basic contamination investigation based on sampling and testing of soil taken from trial pits during the geotechnical investigation.

During the excavation of the trial pits, the use of sight and smell may help to identify certain contaminants.

If the Basic Investigation reveals the presence of geotechnical and/or contamination hazards, or has not addressed all of the original objectives, or where there is any doubt about the condition of the ground, further Detailed Investigation should be conducted.

4.1.6 Detailed Investigation (sites where hazards are identified or suspected)*Also see: BS 10175*

Where hazards are identified or suspected, a Detailed Investigation of the site shall be conducted under the supervision of a consultant or specialist acceptable to NHBC to determine and report on the nature and extent of the conditions.

A Detailed Investigation should be carried out where hazards are identified or suspected:

- from the outset
- from the initial results of the desktop study and walkover survey, or
- from the Basic Investigation.

A consultant or specialist acceptable to NHBC should be appointed to:

- design and supervise the Detailed Investigation
- present all the factual data obtained from the Detailed Investigation.

In addition to the Basic Investigation, the Detailed Investigation should adopt a clearly defined, structured approach, gathering information which considers the:

- immediate site and the adjacent area
- possibility of future development in the vicinity of the site
- nature of the development
- complexity of the ground conditions
- extent of influence of the proposed foundations
- presence of soil gas (if there is any possibility a full gas investigation should be carried out and include flow measurements)
- surface water and ground water conditions, soils and geology, and site history.

The problems and liabilities which have to be managed in order to develop the site should be clearly communicated in the Detailed Investigation report.

Further investigation should be conducted if the Detailed Investigation has not satisfactorily addressed all of the original objectives.

4.1.7 Managing the risks (sites where hazards are found)

Also see: CIRIA Reports C716 and SP164

Hazardous ground conditions shall be satisfactorily managed under the supervision of a consultant or specialist acceptable to NHBC. Items to be taken into account include:

- a) design precautions
- b) remediation techniques
- c) a method statement and report.

The consultant or specialist should:

- identify any results which show that design precautions and/or remediation may be necessary
- conduct a risk assessment to determine appropriate design precautions and/or remedial treatment
- specify the options for remediating any contamination that may be present and provide a remediation method statement
- make recommendations for appropriate design precautions as necessary, including all underground services on the site and any ground improvement techniques
- ensure the works are appropriately supervised
- produce a remediation report.

The proposed solutions for dealing with geotechnical and/or contamination hazards should make due allowance for any constraints that apply, for example:

- factors associated with the site and surrounding area which could restrict the design precautions or remediation techniques should be identified
- local and statutory requirements should be met to avoid abortive works
- time constraints may influence the choice of solution, but do not alter the requirement for effective remediation.

Design precautions

Solutions for dealing with geotechnical hazards include:

- specialist foundations such as rafts, piling and ground beams
- ground improvement techniques such as vibro, dynamic compaction and surcharging.

When dealing with hazardous gases note:

- some radon barriers and gas membranes are manufactured from recycled products. However, these should not be used. Also see Annex C of BS 8485
- where protective measures are required for both radon and other hazardous gases, for example methane or carbon dioxide, it should not be assumed a radon barrier will be effective in such circumstances and further specialist advice should be sought. Also see Annex G of BS 8485.

Remediation techniques

Solutions for dealing with contamination hazards include:

- risk avoidance by changing the pathway or isolating the target, by adjusting the layout and/or by building protective measures into the construction
- engineering-based treatments that remove or isolate contaminants or modify the pathway by excavation, providing ground barriers or covering and capping
- process-based treatment to remove, modify, stabilise or destroy contaminants by physical, biological, chemical or thermal means.

Remediation method statement and report

The remediation method statement should detail the strategy for the site and include the:

- original risk assessment, identification of the remediation objectives and outline information for the method chosen
- remediation objectives for ground, ground water and soil gas
- working method for implementing remediation
- waste classification and methods for control and disposal
- proposed supervision and monitoring of remediation
- validation sampling and testing to be implemented.

The report should include the following information:

- photographic records, especially for work which will be buried (eg membranes)
- site diaries or drawings, environmental supervisor's site diary and independent witness statements where appropriate
- accurate surveys of the levels and position of all remediated areas
- a description of any remedial materials used
- details of soil movements and waste transfer notes
- results of post-remediation sampling (laboratory certificates should be provided in appendices)
- validation test results
- results of monitoring
- details of all consultations and meetings with statutory authorities.

4.1.8 Unforeseen hazards

Where additional or unforeseen hazards arise during construction, the builder shall ensure investigation and management satisfactory to NHBC.

Where additional or unforeseen hazards arise, specialist advice is required so that the hazard is properly investigated, managed and verified.

4.1.9 Documentation and verification

Documentation and verification shall be provided to the satisfaction of NHBC to demonstrate that the site is suitable for the proposed development. All relevant information, designs, specifications and reports shall be produced in a clearly understandable format and distributed to appropriate personnel.

Where the site is within an area susceptible to radon, it will be necessary to follow appropriate guidance in the relevant Building Regulations and associated documents. The information detailed in Table 3 should be provided to NHBC.

Table 3: Information required by NHBC

Geotechnical hazards present:	Yes	No	Yes	No
Contamination hazards present:	Yes	Yes	No	No
Initial Assessment, Further Assessment and Basic Investigation	●	●	●	●
Detailed Investigation	●	●	●	
Proposals to manage geotechnical risks	●		●	
Proposals to manage contamination risks	●	●		
Verification evidence	●	●	●	●

Note

Evidence may still be required by NHBC to substantiate that contamination and hazards are not present on the site.

4.1.10 Guidance for investigations

Also see: BS EN 1997-2

Site investigations shall be undertaken in accordance with BS EN 1997-2 and recognised practice. Items to be taken into account include:

- a) investigation technique
b) sampling
- c) testing.

Investigation technique

A site investigation normally comprises techniques which are classed as either indirect or direct.

Indirect investigations use geophysical techniques, including electromagnetic, resistivity, seismic, gravity and ground radar, to interpret ground conditions. Conducted from the surface, they measure variations in properties of the ground, both horizontally and vertically, to define subsurface conditions. Geophysical methods rely on contrasts in the physical properties, for example, between sand and gravel and rockhead. Contrast may also be provided by faulting, underground cables and pipelines or by cavities.

Direct investigation techniques involve intrusive activities to enable the retrieval and examination of the ground using trial pits, trenches, boreholes or probes.

Trial pits allow the detailed inspection, logging, sampling and in-situ testing of large volumes of natural soil or fill and the assessment of ground water conditions. Trenches are extended trial pits, or linked trial pits, which are excavated where greater exposure of the ground conditions is required. Trial pits and trenches should be positioned where they will not affect future foundations.

Boreholes are typically formed using the following techniques:

Light cable percussion drilling	A shell and auger rig – typically used in the UK to drill boreholes in soils and weak rocks
Continuous flight auger	Exploratory boreholes may be drilled in soils by mechanical continuous flight augers of various sizes. Hollow stem methods are typically employed where sample retrieval is required
Rotary drilling	Either open-hole drilling or rotary coring, is used to investigate rock and sometimes stiff soils, such as boulder clay
Probing techniques	Used to analyse the relative density of soils and for environmental sampling and monitoring (such as chemical and physical testing of gases, liquids and solids)

Sampling

The number and type of samples taken should be:

- appropriate for the results of the desk study, the walkover survey and the site investigation
- appropriate for the range of ground materials encountered and the proposed development
- taken, stored and transported so that they avoid cross-contamination.

Samples are used to enable soil and rock descriptions to be made and to provide material for physical and chemical testing.

‘Undisturbed’ soil and rock samples undergo minimal disturbance, so provide a more reliable indication of the physical soil properties than ‘disturbed’ samples.

Ground water should be collected from appropriately designed monitoring wells which should be screened and sealed to ensure that the relevant stratum is being monitored.

Gas sampling should be carried out from appropriately designed monitoring wells, boreholes or window sampling holes are typically used. Identification of the probable source and the measurement of gas flow are important for risk assessments.

Testing

Testing may be undertaken in-situ, or in a laboratory.

A wide variety of in-situ tests can be used to support the results of direct testing. These range from basic tests undertaken by geologists or engineers using simple hand-held devices or portable test kits to methods that require specialist personnel and equipment.

Testing laboratories should participate in quality assurance programmes and be accredited for relevant tests by bodies such as UKAS and MCERTS. Physical tests on soil and rock materials are carried out to provide the following information on ground:

- strength
- relative density
- deformation
- settlement
- consolidation characteristics
- permeability.

Chemical tests on soils, rocks, ground water and gases can be carried out to provide an indication of potential contamination on the site.

4.1.11 Further information

- BRE: Report BR211 – ‘Radon: Guidance on protective measures for new dwellings (including supplementary advice for extensions, conversions and refurbishment projects)’
- BRE: Report BR212 – ‘Construction of new buildings on gas-contaminated land’
- BRE: Report BR414 – ‘Protective measures for housing on gas contaminated land’
- BRE: Digest 383 – ‘Site investigation for low-rise buildings: Soil description’
- BS 5930 – ‘Code of practice for site investigations’
- BS 8485 – ‘Code of practice for the design of protective measures for methane and carbon dioxide ground gases for new buildings.’
- BS 8576 – ‘Guidance on investigations for ground gas – Permanent gases and volatile organic compounds (VOCs)’
- BS 10175 – ‘Investigation of potentially contaminated sites’
- BS EN ISO 14688 – ‘Geotechnical investigation and testing. Identification and classification of soil: Part 1. Identification and description. Part 2. Principles for a classification’
- BS EN ISO 22476 – ‘Geotechnical investigation and testing. Field testing’
- CIRIA C665 – ‘Assessing risks posed by hazardous ground gasses to buildings’
- CIRIA C716 – ‘Remediating and mitigating risks from volatile organic compounds (VOC) vapours from land affected by contamination’
- CIRIA C735 – ‘Good practice on the testing and verification of protection systems for buildings against hazardous ground gases’
- CIRIA C758D – ‘Abandoned mine workings manual’
- CIRIA C773 – ‘A guide to small brownfield sites and land contamination’
- CIRIA C801 – ‘Hazardous ground gas - a site management guide’
- CIRIA SP164 – Remedial treatment for contaminated land, Volumes I - XII
- DLUHC and its predecessor departments’ publications
- DEFRA and its predecessor departments’ publications
- CLAN 02/05 ‘Soil guideline values and the determination of land as contaminated land under Part 2A’
- Environmental Protection Act 1990: Part 2A Contaminated Land Statutory Guidance – April 2012
- Department of the Environment Industry Profiles – ‘Information on the processes, materials and wastes associated with individual industries’
- Department of the Environment – Waste Management Paper No 27 – ‘Landfill Gas: A technical memorandum on the monitoring and control of landfill gas’ and Environment Agency/Scottish Environment Protection Agency LFTGN 03 ‘Guidance on the management of landfill gas’
- CLEA (Contaminated Land Exposure Assessment) guidance and software Science Reports SR 1,2,3 and 7
- NHBC and Environment Agency R&D Publication 66 – ‘Guidance for the safe development of housing on land affected by contamination’.
- CL:AIRE – ‘Control of Asbestos Regulations 2012: Interpretation for Managing and Working with Asbestos in Soil and Construction and Demolition materials: Industry guidance’
- HSE – ‘Control of Asbestos Regulations 2012’
- NHBC Foundation NF94 – ‘Hazardous ground gas – an essential guide for housebuilders’
- NHBC/RSK Group Plc ‘Guidance on evaluation of development proposals on sites where methane and carbon dioxide are present’ Edition No.: 04 March 2007’.

Figure reference table

Figure reference table 4.1

Fig No	Title/Description	Clause	Page
Figure 1	Procedure flow chart	4.1.1	2



Chapter 4.2



Building near trees

This chapter gives guidance on meeting the Technical Requirements when building near trees, hedgerows and shrubs, particularly in shrinkable soils.

4.2.1	Compliance	01
4.2.2	Provision of information	01
4.2.3	Building near trees	02
4.2.4	The effects of trees on shrinkable soils	03
4.2.5	Foundations in all soil types	06
4.2.6	Excavation of foundations	06
4.2.7	Foundations in shrinkable soils	06
4.2.8	Design and construction of foundations in shrinkable soils	08
4.2.9	Foundation depths for specific conditions in shrinkable soils	09
4.2.10	Heave precautions	10
4.2.11	New drainage	13
4.2.12	Method of assessment of foundation depths using charts	13
4.2.13	Method of assessment of foundation depths using tables	17
4.2.14	Worked example	23
4.2.15	Further information	25

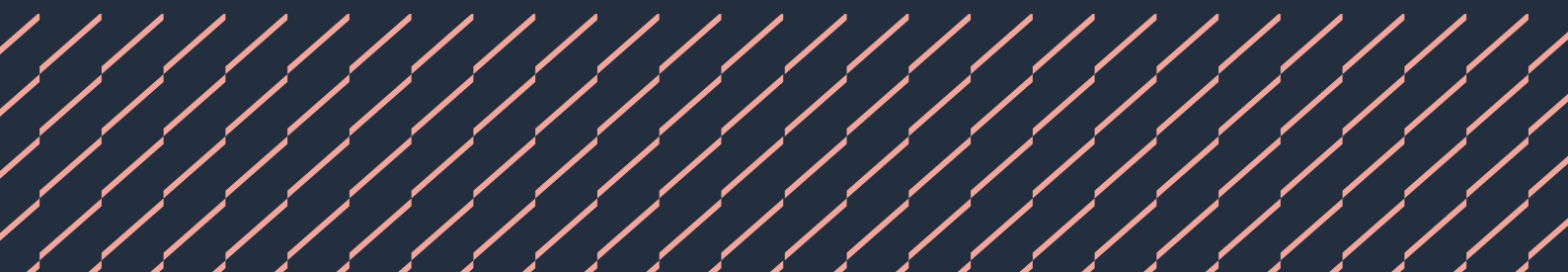

Introduction

The combination of shrinkable soils and trees, hedgerows or shrubs represents a hazard to structures that requires special consideration. Trees, hedgerows and shrubs take moisture from the ground and, in cohesive soils such as clay, this can cause significant volume changes resulting in ground movement. This has the potential to affect foundations and damage the supported structure. In order to minimise this risk, foundations should be designed to accommodate the movement or be taken to a depth where the likelihood of damaging movement is low.

This chapter gives guidance for common foundation types to deal with the hazard and includes suitable foundation depths which have been established from field data, research, NHBC data and practical experience. The depths are not those at which root activity, desiccation and ground movement are non-existent, but they are intended to provide an acceptable level of risk. However, if significant quantities of roots are unexpectedly encountered in the base of the trench, the excavation may need to be deepened.

The interaction between trees, soil and buildings is dependent on many factors and is inherently complex. The relationship becomes less predictable as factors combine to produce extreme conditions. These are signified by the need for deeper foundations. Depths greater than 2.5m indicate that conditions exist where prescriptive guidance is less reliable.

The services of a specialist arboriculturalist may be helpful for the identification of the type and condition of trees that may affect building work. This includes trees both on and adjacent to the site.

Consideration has been given to the potential effects of climate change in the guidance provided.

The following situations are beyond the scope of the guidance in this chapter and will require a site-specific assessment by an engineer (see Technical Requirement R5):

- foundations deeper than 2.5m within the influence of trees
- ground with a slope of greater than 1 in 7 (approximately 8°) and man-made slopes such as embankments and cuttings
- underpinning.

4.2.1 Compliance

Also see: Chapter 2.1

When building near trees, hedgerows or shrubs, all foundations shall comply with the Technical Requirements.

Foundations near trees, hedgerows or shrubs that comply with the guidance in this chapter will generally be acceptable.

4.2.2 Provision of information

Designs and specifications shall be produced in a clearly understandable format, include all relevant information and be distributed to appropriate personnel.

The site plan should show the trees and hedgerows that affect the ground and works, as well as the type, depth and dimensions of the foundations that fall within their influence. Where trees or hedgerows are either not shown or are in different positions and shrinkable soil is identified, it may be necessary to adjust the foundation depths on site.

All necessary dimensions and levels should be indicated and relate to at least one benchmark and reference points on the site.

Details should be provided with respect to:

- technical method statements
- critical sequences of construction
- site layout
- site investigation
- soil volume change potential
- survey, including location and height of trees and hedgerows affecting the site
- tree species (including existing, removed and proposed) using English names
- original and final ground levels
- planting schedules
- dimensions, type and depth of foundations
- locations and detailing of steps in foundations, movement and construction joints, ducts and services passing through the foundations
- location of services
- design of drainage systems.

4.2.3 Building near trees

Also see: *Technical Requirements R5 and BS 5837*

When building near trees, hedgerows or shrubs, the designs shall take account of:

- a) physical growth of young trees
- b) protection of remaining trees and hedgerows
- c) removal of existing trees and hedgerows.

Before the site is cleared, a survey is required to record the location, heights and species of trees, hedgerows and shrubs on and adjacent to the site, which may affect the proposed development.

If the location of previously removed vegetation is not known, local enquiries and reference to aerial photographs should be carried out. Alternatively, the design should assume the worst conditions, or an engineer consulted to undertake a site-specific design based on all relevant information and in accordance with Technical Requirement R5.

Where root growth is noted within shrinkable soil and where records are not available, an engineer should be consulted to assess whether volume change is likely.

Physical growth of young trees

Damage to foundations resulting from the growth of trees and roots should be avoided by locating structures and services at a safe distance. Where this cannot be achieved, precautions which allow for future growth should be taken which include:

- reinforcing foundations to resist lateral forces
- bridging walls or structural slabs over the roots, allowing sufficient clearance or reinforcing to avoid cracking
- laying paving and other surfaces on a flexible base to allow for some movement.

Protection of remaining trees and hedgerows

Roots often extend to distances in excess of the height of the tree, the majority are within 600mm of the surface and project radially. All parts of the system are easily susceptible to damage which may not regenerate and which can affect the stability of the tree.

This can be caused by:

- stripping topsoil too close to trees
- excavating trenches for foundations and services too close to trees
- raising soil levels adjacent to trees, particularly where non-granular materials are used
- the compaction of soil around trees by heavy plant
- the storage of heavy materials around trees
- covering the rooting area with impervious surfaces.

Trees should be protected from damage by:

- a fence or barrier. The fence or barrier should extend around a single trunk equivalent to a circle of radius 12 times the trunk diameter measured 1.5m above ground level. The shape of this area may change depending on specific factors such as local drainage, soil type, age and species of the tree. An arboriculturist may be required to assess these factors
- ensuring services are not routed close to trees or, where this is impractical, are installed in such a way as to minimise root damage.

Removal of existing trees and hedgerows

Statutory Requirements, planning conditions, conservation area restrictions or tree preservation orders may result in protected trees and hedgerows being retained. The local planning authority should be consulted.

Dead trees and hedgerows should be removed. Unstable trees should be made steady or felled. If necessary, specialist advice should be obtained from a registered arboriculturist.

4.2.4 The effects of trees on shrinkable soils

Foundations shall be designed to make allowance for the effect of trees, hedgerows and shrubs on shrinkable soils. Items to be taken into account include:

- a) soil classification, shrinkage and heave
- b) water demand, tree heights and zone of influence of trees
- c) climate.

Soil classification, shrinkage and heave

Shrinkable soils, that are widely distributed throughout the UK, often change volume as moisture content fluctuates seasonally and as a result of factors, including the action of tree roots. The resulting shrinkage or swelling can cause subsidence or heave damage to foundations, the structures they support and services.

The following definitions are used to classify soil properties:

Shrinkable soils	Over 35% fine particles and a Modified Plasticity Index of 10% or greater
Fine particles	Nominal diameter less than 60µm, ie, clay and silt particles
Plasticity Index (Ip)	A measure of volume change potential determined by Atterberg Limits tests. These tests are carried out on the fine particles and any medium and fine sand particles. Soil particles with a nominal diameter greater than 425µm are removed by sieving beforehand and the smaller particles analysed. This is a requirement of BS 1377 which specifies the test procedure
Modified Plasticity Index (I'p)	Defined as the Ip of the soil multiplied by the percentage of particles less than 425µm $I'p = \frac{Ip \times \% \text{ less than } 425\mu\text{m}}{100\%}$

Table 1: Modified Plasticity Index related to volume change potential

Modified Plasticity Index	Volume change potential
40% and greater	High
20% to less than 40%	Medium
10% to less than 20%	Low

Alternatively, the Plasticity Index may be used without modification. For pure clays and other soils with 100% of particles less than 425µm, the result will be the same. However, for mixed soils such as glacial tills, use of the Modified Plasticity Index may result in a more economic design.

The volume change potential should be established from site investigation and reliable local knowledge of the geology. Sufficient samples should be taken to provide confidence that the results are representative. High volume change potential should be assumed if the volume change potential is unknown.

Water demand, tree heights and lateral zone of tree influence

Water demand varies according to tree species and size. Water demand categories of common tree species are given in the table below.

Where the species of a tree has not been identified, high water demand should be assumed.

Where the species of a tree has been identified but is not listed, the assumptions about water demand as listed in Table 2 may be made for broad-leaved trees:

Table 2: Water demand of broad-leaf trees by species

Tree species	Water demand
All elms, eucalyptus, hawthorn, oaks, poplars and willows	High water demand
All others	Moderate water demand

Table 3 shows the water demand categories and the average mature heights to which healthy trees of the species may be expected to grow in favourable ground and environmental conditions. This information:

- should be used for trees that are to remain or are scheduled to be planted
- may be used even when actual heights are greater.

Table 3: Water demand of tree species in relation to their height

High water demand species	Mature height (m)	Moderate water demand species	Mature height (m)	Low water demand species	Mature height (m)
Broad-leaved trees:					
English elm	24	Acacia (False)	18	Birch	14
Wheatley elm	22	Alder	18	Elder	10
Wych elm	18	Apple	10	Fig	8
Eucalyptus	18	Ash	23	Hazel	8
Hawthorn	10	Bay laurel	10	Holly	12
English oak	20	Beech	20	Honey locust	14
Holm oak	16	Blackthorn	8	Hornbeam	17
Red oak	24	Japanese cherry	9	Laburnum	12
Turkey oak	24	Laurel cherry	8	Magnolia	9
Hybrid black poplar	28	Orchard cherry	12	Mulberry	9
Lombardy poplar	25	Wild cherry	17	Tulip tree	20
White poplar	15	Horse chestnut	20		
Crack willow	24	Sweet chestnut	24		
Weeping willow	16	Lime	22		
White willow	24	Japanese maple	8		
		Norway maple	18		
		Mountain ash	11		
		Pear	12		
		Plane	26		
		Plum	10		
		Sycamore	22		
		Tree of heaven	20		
		Walnut	18		
		Whitebeam	12		
Coniferous trees:					
Lawson's cypress	18	Cedar	20		
Leyland cypress	20	Douglas fir	20		
Monterey cypress	20	Larch	20		
		Monkey puzzle	18		
		Pine	20		
		Spruce	18		
		Wellingtonia	30		
		Yew	12		

Tree identification can be assisted by reference to a tree recognition book. Information may be obtained from suitable alternative authoritative sources for trees not listed in this chapter.

When the species is known but the subspecies is not, the greatest height listed for the species should be assumed.

Where hedgerows contain trees, their effect should be assessed separately and the height of the species likely to have the greatest effect should be used.

Table 3a provides guidance to be used in assessing the effects of trees and their water demand when they are subjected to heavy crown reduction or removal. For trees which have been or are to be removed, allowance should be made for the fact that the water demand of a tree varies with its size and rate of growth.

Table 3b, on the other hand gives the lateral extent of the zone of influence of trees. So any foundation located within these zones will be influenced by the tree and should be designed to meet the requirements of this chapter.

Table 3a: Guidance for factors affecting the mature height and water demand of trees

Influencing factor	Guidance
Heavy crown reduction or pollarding (previously or planned)	The mature height should be used, or a registered arboriculturalist should be consulted to undertake a site-specific assessment.
Removal of trees (previously or planned)	<p>The water demand of a semi-mature tree may be equal to that of a mature tree, though for a sapling or young tree will be significantly less.</p> <div style="display: flex; align-items: center;">  <div style="margin-left: 20px;"> <p>Height H should be determined in accordance with this diagram when:</p> <ul style="list-style-type: none"> • deriving foundation depths when trees have been removed, based on tree height at the time of removal • checking the appropriate level from which depths should be measured when trees remain and the ground level is increased, based on tree height at time of construction relative to original ground level – see Fig 1 of clause 4.2.9 b, or • determining if heave precautions are to be provided, based on tree height at time of construction – see clause 4.2.10 d </div> </div>

Table 3b: Zone of influence (lateral extent) of trees

Water demand	Zone of influence
High	1.25 x mature height
Moderate	0.75 x mature height
Low	0.5 x mature height

Climate

High rainfall reduces moisture deficits caused by trees and hedgerows, while cool, damp weather reduces the rate of water loss from trees thus reducing the risk of soil movement.

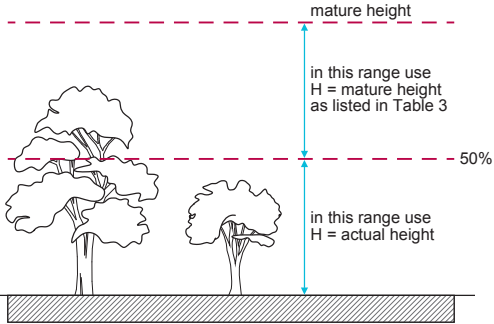
The driest and hottest areas in the UK generally exist in southeast England; therefore, the greatest risk occurs in that area and diminishes with distance north and west. A 50mm decrease can be made to the foundation depth determined in accordance with this chapter for every 50 miles distance north and west of London. Where it is unclear which zone applies, the lower reduction value should be used.

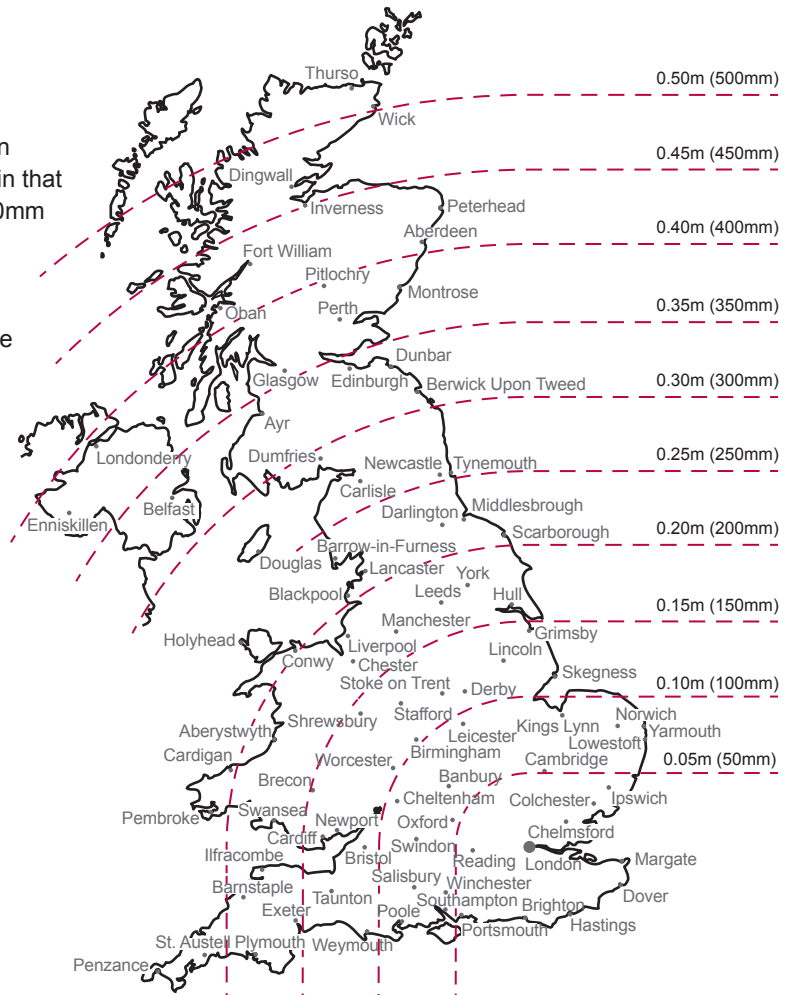

4.2.5 Foundations in all soil types

Foundations in all soil types shall be appropriately designed and constructed to transmit loads to the ground safely and without excessive movement.

Different foundation types should not be used to support the same structure unless the foundation and superstructure design are undertaken by an engineer.

Freestanding masonry walls should be constructed on foundations in accordance with this chapter or designed to accommodate potential ground movement, for example, by careful use of movement joints and reinforcement.

4.2.6 Excavation of foundations

Also see: Chapter 4.1, 4.3, 4.4, 4.5 and Technical Requirement R5

Excavation of foundations shall take account of the design and be suitable to receive concrete.

Where trench bottoms become excessively dried or softened due to rain or ground water, the excavation should be re-bottomed prior to concreting.

Foundation depths should be measured on the centre line of the excavation and from ground level determined from Clause 4.2.9.

Some root activity may be expected below the depths determined in accordance with this guidance. However, if significant quantities of roots are unexpectedly encountered in the base of the trench, an engineer should be consulted to determine if the excavation should be deepened.

4.2.7 Foundations in shrinkable soils

Also see: NHBC Foundation Depth Calculator App: www.nhbc.co.uk/apps

Foundations shall be capable of accommodating the effects of trees, shrubs and hedgerows on shrinkable soils without excessive movement. Items to be taken into account include:

- | | |
|--|--|
| a) foundation type | d) foundation depths related to the zone of influence of new tree planting |
| b) distance between tree and foundation | e) foundation depths related to new shrub planting. |
| c) method of assessment of foundation depths | |

Landscape and foundation designs should be compatible, and planting schedules produced by a qualified landscape architect or other suitably qualified person and agreed with the local planning authority before work commences on site.

Foundation type

Foundations to all permanent structures, including garages, porches and conservatories, should take account of the effects of soil desiccation. Foundation types that are acceptable in shrinkable soils include strip, trench fill, pier and beam, pile and beam, and raft, providing they:

- are capable of supporting the applied loads without undue settlement
- include suitable heave precautions.

Variations to the foundation depths derived from this chapter may be permitted where:

- it is necessary to take account of local ground conditions
- other foundation depths are traditionally acceptable
- designed in accordance with Technical Requirement R5.

Root barriers are not an acceptable alternative to the guidance given.

Distance between tree and foundation

The distance (D) between the centre of the trunk and the nearest face of the foundation should be used to derive the foundation depths.

$D = 2m$ where trees which have been, or are to be, removed from within 2m of the face of the proposed foundation are less than 50% of the mature height as given in Table 3. This is to avoid a situation where, for example, a 'sapling' removed from the foundation line would otherwise require an unnecessarily deep foundation since the D/H value would always be zero, regardless of the height H of the tree.

Method of assessment of foundation depths

Foundation depths should be determined according to the guidance provided in this document. If in doubt, assume the worst conditions or consult an engineer. Foundations deeper than 2.5m should be designed by an engineer in accordance with Technical Requirement R5.

One of the following methods may be used to assess the foundation depth where foundations are in the zone of influence of existing or proposed trees.

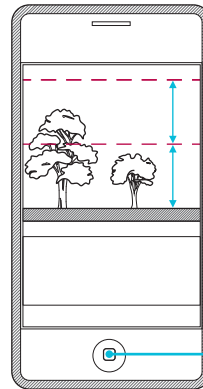

Foundation Depth Calculator App.
www.nhbc.co.uk/apps

Method	Taking account of	Comments
Design in accordance with this chapter to a depth derived from the charts in Clause 4.2.12, tables in Clause 4.2.13 or the Foundation Depth Calculator App	<ul style="list-style-type: none"> site investigation soil volume change potential water demand of the tree appropriate tree height (H) distance (D) of the tree(s) from the foundations geographical location of the site north and west of London appropriate heave precautions 	The most onerous conditions should be assumed in the absence of derived information
Design by an engineer in accordance with Technical Requirement R5	<ul style="list-style-type: none"> the recommendations of this chapter site investigation advice, when necessary, from a registered arboriculturalist or other competent person whose qualifications are acceptable to NHBC 	When this method is used and it results in foundation depths or other details less onerous than those derived from this chapter, the design should be submitted to NHBC prior to work commencing on site

Foundation depths related to the zone of influence of new tree planting

Foundation depths relating to the zone of influence of proposed tree planting should be in accordance with any of the following:

- foundation depth charts in Clause 4.2.12
- the Foundation Depth Calculator App.
- tables in Clause 4.2.13

Minimum foundation depths outside of the zone of influence of trees can be determined from Tables 4 and 5.

Table 4: Minimum foundation depths

Volume change potential	A) Minimum foundation depth (m) (allowing for restricted new planting)	B) Minimum foundation depth (m) (where planting is outside the zone of influence of trees)
High	1.50	1.0
Medium	1.25	0.9
Low	1.0	0.75

Table 5: Where foundation depths are in accordance with column A or column B in Table 4, tree planting should be restricted to:

Water demand	No tree planting zone for column A in Table 4	No tree planting zone / zone of influence for column B in Table 4
High	1.0 x mature height	1.25 x mature height
Moderate	0.5 x mature height	0.75 x mature height
Low	0.2 x mature height	0.50 x mature height

Foundation depths related to new shrub planting

Shrubs have considerable potential to cause changes in soil moisture content. The foundation design should consider shrub planting in accordance with Table 6.

Table 6: Shrub planting

Volume change potential	A) Minimum foundation depth (m)	B) Minimum foundation depth (m)
High	1.50	1.0
Medium	1.25	0.9
Low	1.0	0.75

The foundation design should consider shrub planting as follows:

Shrubs that have a maximum mature height of 1.8m	Use foundation depth from column B
Climbing shrubs which require wall support and have a maximum mature height of 5.0m	Use foundation depth from column B
Pyracantha and cotoneaster whose mature height exceeds 1.8m	Use foundation depth from column B and plant at least 1.0 x mature height from foundation, or use foundation depth from column A and plant at least 0.5 x mature height from foundation
All others	Use foundation depth from column B and plant at least 0.75 x mature height from foundation, or use foundation depth from column A with no restriction on minimum distance from foundation

Also see: BRE Digest 298,
Chapters 4.3, 4.4 and
Technical Requirement R5

4.2.8 Design and construction of foundations in shrinkable soils

Foundations in shrinkable soils shall be appropriately designed and constructed.

Reference should be made to Clause 4.2.10 to establish the precautions necessary to cater for potential heave.

The following will only be acceptable if they are designed by an engineer and account for all potential movement of the soil on the foundations and substructure:

- trench fill foundations deeper than 2.5m
- pier and beam foundations
- pile and beam foundations
- rafts.

Trench fill foundations

If trench fill foundations are deeper than 2.5m:

- the instability of the trench sides can lead to serious construction difficulties
- the design should take account of plot specific soil desiccation and the associated arboricultural advice
- additional heave precautions may be necessary to cater for lateral and shear forces acting on large vertical areas of foundation
- concrete overspill or overbreak in excavations should be avoided in order to reduce the possibility of additional vertical forces being transmitted to the foundation
- compressible material should be correctly placed to avoid excessive heave forces being applied to the foundations
- construction joints need to be detailed to account for increased lateral forces.

Pier and beam foundations

Pier depths not exceeding 2.5m depth may be derived from Clause 4.2.7. Pier depths greater than 2.5m require site specific assessment.

Pile and beam foundations

When selecting and designing pile and ground beam foundations, piles should be:

- designed with an adequate factor of safety to resist uplift forces on the shaft due to heave
- reinforced for the length of the member governed by the heave design.

Sufficient anchorage should be provided below the depth of desiccated soil. Slip liners may be used to reduce uplift but the amount of reduction is small, as friction between materials cannot be eliminated.

Bored, cast-in-place piles are well suited to counteracting heave. Most types have a straight-sided shaft, while some are produced with a contoured shaft to increase load capacity. The design should allow for the enhanced tensile forces in these piles.

Driven piles are less well suited to counteracting heave and are difficult to install in stiff desiccated clay without excessive noise and vibration. The joint design of these piles should be capable of transmitting tensile heave forces.

Ground beams should be designed to account for the upward forces acting on their underside and transmitted from the compressible material or void former prior to collapse, and in accordance with the manufacturer's recommendations.

Raft foundations

Raft foundations in shrinkable soils will only be acceptable where all of the following apply:

- design is by an engineer in accordance with Technical Requirement R5
- NHBC is satisfied that the raft is sufficiently stiff to resist differential movements
- NHBC is satisfied that the raft is founded on granular infill placed and fully compacted in layers and in accordance with the engineer's specification. Where required by NHBC, site inspections are to be undertaken by the engineer to verify suitable compaction of the fill
- the raft is generally rectangular in plan with a side ratio of not more than 2:1
- foundation depth is derived in accordance with Clause 4.2.7, and is less than 2.5m.

4.2.9 Foundation depths for specific conditions in shrinkable soils

Foundations in shrinkable soils shall be designed to transmit loads to the ground safely and without excessive movement. Items to be taken into account include:

- | | |
|--|---|
| a) strip and trench fill foundations in non-shrinkable soils overlying shrinkable soil | c) granular infill beneath raft foundations in shrinkable soils |
| b) measurement of foundation depths | d) steps in foundations. |

Strip and trench fill foundations in non-shrinkable soils overlying shrinkable soil

Non shrinkable soils such as sands and gravels may overlie shrinkable soil. Foundations may be constructed on overlying non-shrinkable soil if all the following are satisfied:

- conditions of Chapter 4.3 'Strip and trench fill foundations' are met
- consistent soil conditions exist across each plot and this is confirmed by the site investigation
- depth of the non-shrinkable soil is greater than $\frac{3}{4}$ foundation depth X, where X is the foundation depth determined using charts in Clause 4.2.12, tables in Clause 4.2.13 or the Foundation Depth Calculator App, assuming all the soil is shrinkable
- the thickness T of non-shrinkable soil below the foundation is equal to, or more than, the width of the foundation B
- proposals are submitted to, and approved by, NHBC prior to work commencing on site.

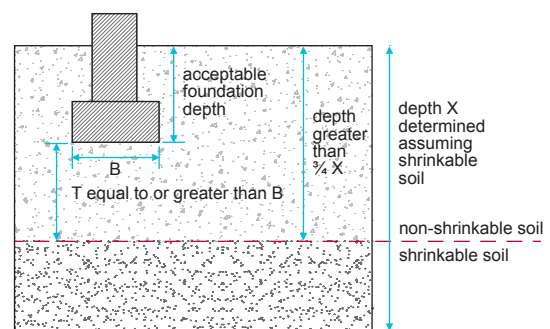

Where any of the above are not met foundation depths should be determined as for shrinkable soil.

Measurement of foundation depths

Where ground levels are to remain unaltered, foundation depths should be measured from original ground level.

Measurement of foundation depths where ground levels are reduced or increased, either in the recent past or during construction, should be as shown in figures 1, 2 and 3.

Figure 1: Levels from which foundation depths are measured where trees or hedgerows are to remain

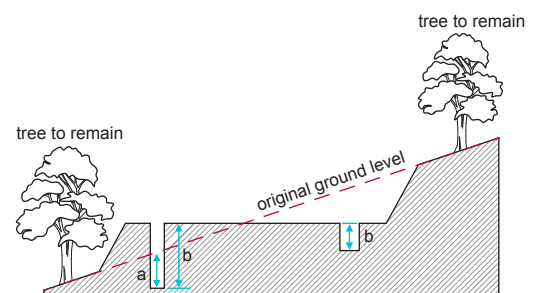

Use the lower of:
a) foundation depth based on appropriate tree height (see Table 3a)
b) foundation depth based on mature height of tree.

Figure 2: Levels from which foundation depths are measured where trees or hedgerows are removed

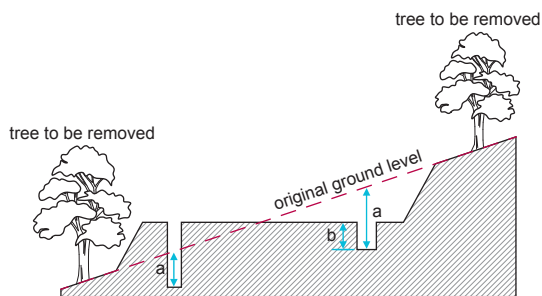

Use the lower of:
a) foundation depth based on appropriate tree height (see Table 3a)
b) minimum foundation depth (see Table 4 column B).

Figure 3: Levels from which foundation depths are measured where trees or hedgerows are proposed



Use the lower of:
a) minimum foundation depth (see Table 4 column B)
b) foundation depth based on mature height of tree.

Granular infill beneath raft foundations in shrinkable soils

Granular infill together with raft slab foundation can be used as an alternative to deep trench fill foundation. Where adopted, granular infill should be placed beneath raft foundations on shrinkable soils as shown below.

Infill should:

- be at least 50% of the foundation depth determined for a trench fill foundation and not more than 1.25m deep (measured from ground level determined in accordance with 4.2.9b)
- extend beyond the edge of the foundation by a distance equal to its natural angle of repose, plus 0.5m.
- be placed in accordance with specification within Chapter 4.6 'Engineered fill'.

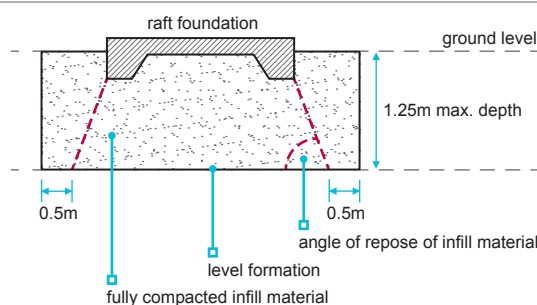

Steps in foundations

On sloping ground, foundation trenches can be gradually stepped so that the required foundation depth is reasonably uniform below ground level.

Where foundations are to be stepped to take account of the influence of trees, hedgerows and shrubs, they should be stepped gradually, with no step exceeding 0.5m.

4.2.10 Heave precautions

Also see: BRE Digests 240 & 241; Chapter 2.1 and BS 5837

Foundations, substructures and services shall be suitably designed and detailed to prevent excessive movement due to heave. Heave precautions shall be incorporated into foundations and substructures in accordance with the design. Items to be taken into account include:

- | | |
|--------------------------------------|----------------------------|
| a) potential for ground movement | e) other foundation types |
| b) minimum void dimensions | f) suspended ground floors |
| c) proprietary heave materials | g) paths and driveways. |
| d) heave precautions for foundations | |

Where foundations and substructure may be subject to heave, they should be protected by voids, void formers or compressible materials.

Where proprietary materials are used, the design of foundations and substructure should take into account the upward force transmitted through the compressible material or void former prior to collapse (refer to manufacturer's data).

This section provides guidance on heave precautions for common building elements when located within the influence of trees which are to remain or be removed, including:

- trench fill foundations
- pier and beam foundations
- pile and beam foundations
- other foundation types
- paths and driveways
- new drainage.

Potential for ground movement

After the felling or removal of trees and hedgerows on shrinkable soils, heave can occur, as the absorbed moisture causes swelling. Heave can also occur beneath a building where:

- roots are severed
- there are changes in ground water conditions.
- water enters the ground from leaking drains and services

Minimum void dimensions

Voids should be provided to accommodate movement due to heave forces acting against foundations and suspended ground floors in accordance with Table 7.

Table 7: Void dimensions

Volume change potential	Void dimension against side of foundation and ground beam	Void dimension under ground beams, and suspended in-situ concrete ground floor	Void dimension under suspended precast concrete and timber floors ⁽¹⁾
High	35mm	150mm	300mm
Medium	25mm	100mm	250mm
Low	0mm	50mm	200mm

Notes

1 Under suspended floors, the void dimension is measured from the underside of beam or joist to ground level and includes 150mm ventilation allowance.

Void formers consist of materials that collapse to form a void into which the clay can swell. The void dimension is the 'remaining void' after collapse. The thickness of the void former should be in accordance with the manufacturer's recommendations.

Proprietary materials to accommodate heave

Compressible material compacts as clay expands; the void dimension is the amount the material should be able to compress to accommodate heave. The thickness of compressible material required should be established from the manufacturer's recommendations, but generally will be approximately twice the void dimension shown.

Each material should be assessed in accordance with Technical Requirement R3 and used in accordance with the independent assessment and the manufacturer's recommendations.

The correct placement of heave materials is essential to ensure the foundations and substructure are adequately protected from heave forces.

Heave precautions for foundations

Table 8 shows where heave precautions are required for trench fill, pier and beam, and pile and beam foundation types which are in the zone of influence of trees (see Table 3b) which are to remain or be removed.

Table 8: Position of heave precautions

Situation (see figures 4, 5 & 6)	Trench fill	Pier and beam	Pile and beam
External trench fill and pier foundations. Unless NHBC is satisfied that the soil is not desiccated compressible material should be provided to the:	Inside faces of external wall foundations deeper than 1.5m, based on the appropriate tree height	All faces of pier foundations deeper than 1.5m, based on the appropriate tree height	N/A
External ground beams Unless NHBC is satisfied that the soil is not desiccated compressible material or void formers should be provided to the:	N/A	Inside faces	Inside faces
Internal trench fill foundations and ground beams Compressible material required:	No	No	No
External and internal ground beams Compressible material, void former or void should be provided to the underside of:	N/A	All	All
Heave precautions required for proposed trees where the soil is not desiccated:	No	No	No

On pilecaps, heave precaution measures should be assessed on a project-by-project basis. Lightly loaded pilecaps consisting of between one and three piles are more susceptible to heave movement than heavily loaded pilecaps. Omission of heave precaution measures should be justified by the designers, particularly on lightly loaded pilecaps.

Figure 4: Heave precautions for trench fill foundations up to 2.5m deep

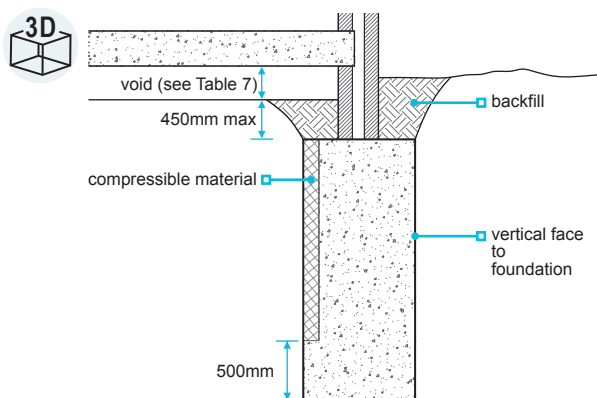

It is essential that:

- Compressible material is provided to the entire area shown, and the foundation excavation has a vertical face.
- Where the excavation is battered or if there is overbreak or concrete overspill, it may be necessary to consult an engineer.

Figure 5: Heave precautions for pier and beam foundations

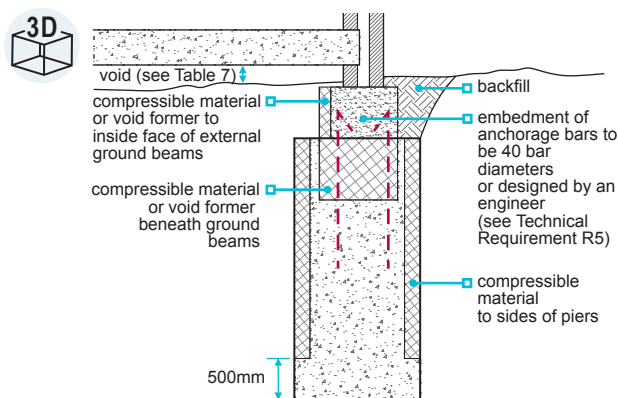

It is essential that heave material is provided to the entire areas shown. Particular care should be taken to ensure that the full width of the ground beam is protected.

Figure 6: Heave precautions for pile and beam foundations

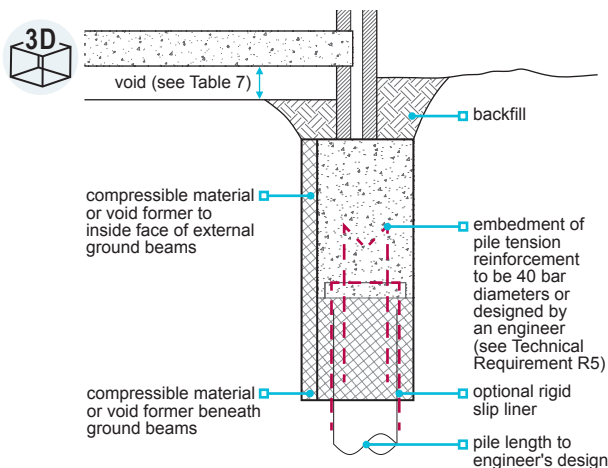

It is essential that heave material is provided to the entire areas shown. Particular care should be taken to ensure that the full width of the ground beam and the areas around the piles are protected.

Raft foundations constructed in accordance with Clause 4.2.8 and Clause 4.2.9 should provide adequate protection from heave.

Other foundation types

All foundations not covered in this chapter, but specifically designed to counteract heave, should be:

- designed by an engineer taking account of this guidance
- submitted to NHBC prior to commencing work on site.

Suspended ground floors

Suspended ground floors with voids in accordance with Table 7 should be used in situations where heave can occur within the area bounded by the foundations, including where:

- foundation depth, determined in accordance with this chapter, is more than 1.5m, unless NHBC is satisfied the soil is not desiccated, or
- ground floor construction is undertaken when the surface soils are seasonally desiccated (ie, during summer and autumn), unless NHBC is satisfied the soil is not desiccated.

Paths and driveways

Paths and driveways should be designed and detailed to cater for the likely ground movement.

4.2.11 New drainage*Also see: Chapter 5.3***Drainage shall be in accordance with the design and allow for ground movement.**

To protect against the effects of heave, drainage should be designed:

- to take account of potential ground movement as shown in Table 9, including where pipes and services pass through substructure walls or foundations
- with gradients which may need to be greater than those in Chapter 5.3 'Drainage below ground' as these do not account for possible ground movement
- to use alternative means of catering for the movement when sufficient falls cannot be provided, for example by deepening the excavation and laying the pipework on a granular bedding of suitable thickness to reduce the extent of potential movement.

Table 9: Volume change potential

Volume change potential	Potential ground movement (mm)
High	150
Medium	100
Low	50

Note

Existing land drains should be maintained or diverted.

Where the void beneath a suspended floor is liable to flooding, adequate drainage should be provided to take away any flood water.

4.2.12 Method of assessment of foundation depths using charts**Foundation depths shall be determined to prevent excessive movement due to ground heave.**

A detailed method of assessing foundation depths of up to 2.5m using Charts 1-3 are given in the worked Example of clause 4.2.14 of this chapter.

Table 10 can be used in determining the D/H ratio needed for use within the charts, where:

D is the distance measured from the centre of the trees or hedgerows to the face of the foundation and**H** is the appropriate height of trees (mature or actual, depending on what is being assessed).

Table 10: Determination of D/H value

Determination of D/H value															
Distance D (m)	Tree H (m)														
	2	4	6	8	10	12	14	16	18	20	22	24	26	28	30
1	0.50	0.25	0.17	0.13	0.10	0.08	0.07	0.06	0.06	0.05	0.05	0.04	0.04	0.04	0.03
2	1.00	0.50	0.33	0.25	0.20	0.17	0.14	0.13	0.11	0.10	0.09	0.08	0.08	0.07	0.07
3		0.75	0.50	0.38	0.30	0.25	0.21	0.19	0.17	0.15	0.14	0.13	0.12	0.11	0.10
4		1.00	0.67	0.50	0.40	0.33	0.29	0.25	0.22	0.20	0.18	0.17	0.15	0.14	0.13
5			0.83	0.63	0.50	0.42	0.36	0.31	0.28	0.25	0.23	0.21	0.19	0.18	0.17
6			1.00	0.75	0.60	0.50	0.43	0.38	0.33	0.30	0.27	0.25	0.23	0.21	0.20
7			1.17	0.88	0.70	0.58	0.50	0.44	0.39	0.35	0.32	0.29	0.27	0.25	0.23
8				1.00	0.80	0.67	0.57	0.50	0.44	0.40	0.36	0.33	0.31	0.29	0.27
9				1.13	0.90	0.75	0.64	0.56	0.50	0.45	0.41	0.38	0.35	0.32	0.30
10					1.00	0.83	0.71	0.63	0.56	0.50	0.45	0.42	0.38	0.36	0.33
11					1.10	0.92	0.79	0.69	0.61	0.55	0.50	0.46	0.42	0.39	0.37
12					1.20	1.00	0.86	0.75	0.67	0.60	0.55	0.50	0.46	0.43	0.40
13						1.08	0.93	0.81	0.72	0.65	0.59	0.54	0.50	0.46	0.43
14						1.17	1.00	0.88	0.78	0.70	0.64	0.58	0.54	0.50	0.47
15							1.07	0.94	0.83	0.75	0.68	0.63	0.58	0.54	0.50
16							1.14	1.00	0.89	0.80	0.73	0.67	0.62	0.57	0.53
17							1.21	1.06	0.94	0.85	0.77	0.71	0.65	0.61	0.57
18								1.13	1.00	0.90	0.82	0.75	0.69	0.64	0.60
19								1.19	1.06	0.95	0.86	0.79	0.73	0.68	0.63
20									1.11	1.00	0.91	0.83	0.77	0.71	0.67
21									1.17	1.05	0.95	0.88	0.81	0.75	0.70
22										1.10	1.00	0.92	0.85	0.79	0.73
23										1.15	1.05	0.96	0.88	0.82	0.77
24										1.20	1.09	1.00	0.92	0.86	0.80
25											1.14	1.04	0.96	0.89	0.83
26											1.18	1.08	1.00	0.93	0.87
27												1.13	1.04	0.96	0.90
28												1.17	1.08	1.00	0.93
29												1.21	1.12	1.04	0.97
30													1.15	1.07	1.00
31													1.19	1.11	1.03
32														1.14	1.07
33														1.18	1.10
34														1.21	1.13
35															1.17
36															1.20

Where no value is given in the table, minimum foundation depths apply (ie, 1.0m, 0.9m and 0.75 m for high, medium and low volume change potential soils respectively).

Chart 1: Soils with HIGH volume change potential – Modified Plasticity Index 40% or greater

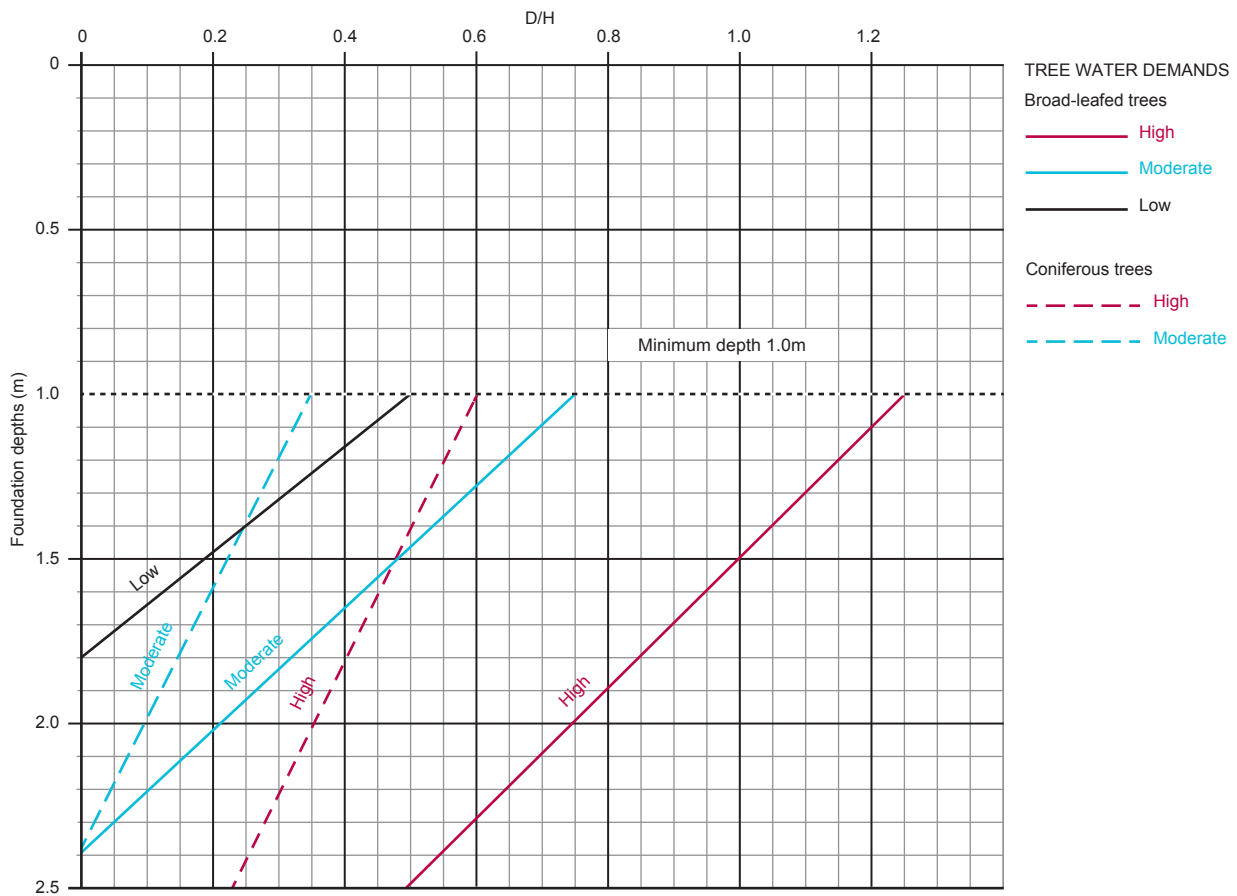

Chart 2: Soils with MEDIUM volume change potential – Modified Plasticity Index between 20% and less than 40%

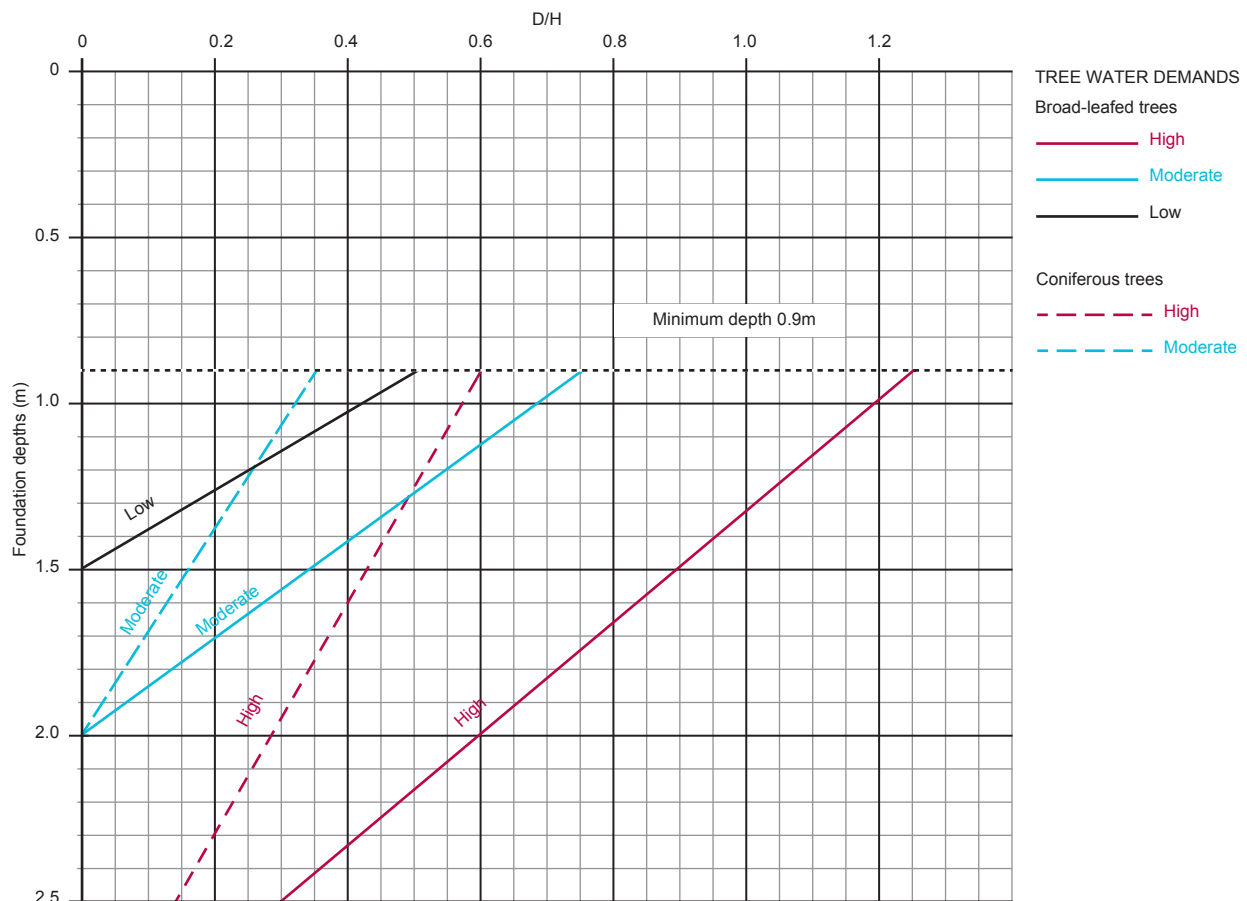

Chart 3: Soils with LOW volume change potential – Modified Plasticity Index 10 to less than 20%

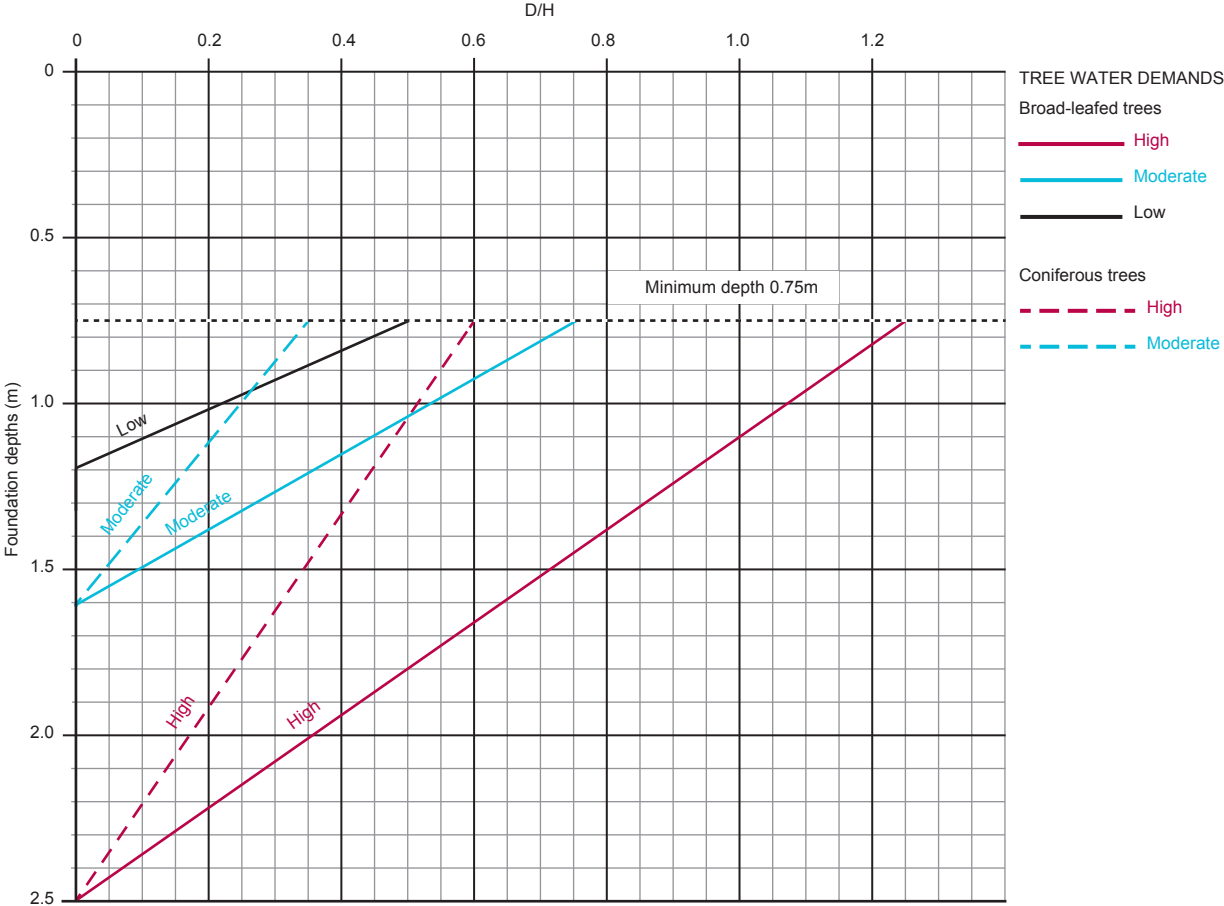

Table 12: HIGH volume change potential soil and MODERATE water demand tree

Broad-leafed trees													Coniferous trees												
Foundation depth (m)													Foundation depth (m)												
Distance D (m)	Tree height H (m)												Distance D (m)	Tree height H (m)											
	8	10	12	14	16	18	20	22	24	26	28	30		8	10	12	14	16	18	20	22	24	26	28	30
1	2.20	2.25	2.25	2.30	2.30	2.30	2.35	2.35	2.35	2.35	2.35	2.35	1.90	2.00	2.10	2.15	2.15	2.20	2.20	2.25	2.25	2.25	2.30	2.30	
2	1.95	2.05	2.10	2.15	2.20	2.20	2.25	2.25	2.25	2.30	2.30	2.30	1.40	1.60	1.75	1.85	1.90	2.00	2.00	2.05	2.10	2.10	2.15	2.15	
3	1.70	1.85	1.95	2.00	2.05	2.10	2.15	2.15	2.20	2.20	2.20	2.25	1.00	1.20	1.40	1.55	1.65	1.75	1.80	1.85	1.90	1.95	2.00	2.00	
4	1.50	1.65	1.80	1.90	1.95	2.00	2.05	2.10	2.10	2.15	2.15	2.15		1.00	1.10	1.30	1.40	1.55	1.60	1.70	1.75	1.80	1.85	1.90	
5	1.25	1.50	1.65	1.75	1.85	1.90	1.95	2.00	2.05	2.05	2.10	2.10			1.00	1.00	1.15	1.30	1.40	1.50	1.60	1.65	1.70	1.75	
6	1.00	1.30	1.50	1.60	1.70	1.80	1.85	1.90	1.95	2.00	2.00	2.05				1.00	1.10	1.20	1.35	1.40	1.50	1.55	1.60		
7	1.00	1.10	1.35	1.50	1.60	1.70	1.75	1.85	1.90	1.90	1.95	2.00					1.00	1.00	1.15	1.25	1.35	1.40	1.50		
8		1.00	1.20	1.35	1.50	1.60	1.65	1.75	1.80	1.85	1.90	1.90						1.00	1.10	1.20	1.30	1.35			
9			1.00	1.20	1.35	1.50	1.60	1.65	1.70	1.75	1.80	1.85							1.00	1.05	1.15	1.20			
10			1.00	1.10	1.25	1.40	1.50	1.55	1.65	1.70	1.75	1.80								1.00	1.00	1.10			
11				1.00	1.15	1.30	1.40	1.50	1.55	1.65	1.70	1.75									1.00	1.00	1.10		
12					1.00	1.20	1.30	1.40	1.50	1.55	1.60	1.65											1.00		
13					1.00	1.05	1.20	1.30	1.40	1.50	1.55	1.60													
14						1.00	1.10	1.25	1.35	1.40	1.50	1.55													
15							1.00	1.15	1.25	1.35	1.40	1.50													
16								1.00	1.05	1.20	1.25	1.35	1.40												
17									1.00	1.10	1.20	1.30	1.35												
18										1.00	1.15	1.20	1.30												
19											1.00	1.05	1.15	1.25											
20												1.00	1.10	1.20											
21													1.00	1.10	1.20										
22														1.00	1.05										
23																1.00									

Table 13: HIGH volume change potential soil and LOW water demand tree

Broad-leafed trees												
Foundation depth (m)												
Distance D (m)	Tree height H (m)											
	8	10	12	14	16	18	20	22	24	26	28	30
1	1.60	1.65	1.70	1.70	1.70	1.75	1.75	1.75	1.75	1.75	1.75	1.75
2	1.40	1.50	1.55	1.60	1.60	1.65	1.65	1.65	1.65	1.70	1.70	1.70
3	1.20	1.35	1.40	1.50	1.50	1.55	1.60	1.60	1.60	1.65	1.65	1.65
4	1.00	1.20	1.30	1.35	1.40	1.45	1.50	1.55	1.55	1.55	1.60	1.60
5		1.00	1.15	1.25	1.30	1.40	1.40	1.45	1.50	1.50	1.55	1.55
6			1.00	1.15	1.20	1.30	1.35	1.40	1.40	1.45	1.50	1.50
7				1.00	1.10	1.20	1.25	1.30	1.35	1.40	1.40	1.45
8					1.00	1.10	1.20	1.25	1.30	1.35	1.35	1.40
9						1.00	1.10	1.15	1.20	1.25	1.30	1.35
10							1.00	1.10	1.15	1.20	1.25	1.30
11								1.00	1.10	1.15	1.20	1.25
12									1.00	1.10	1.15	1.20
13										1.00	1.10	1.15
14											1.00	1.05
15												1.00

Table 14: MEDIUM volume change potential soil and HIGH water demand tree

Broad-leafed trees													Coniferous trees																	
Foundation depth (m)													Foundation depth (m)																	
Distance D (m)	Tree height H (m)												Distance D (m)	Tree height H (m)																
	8	10	12	14	16	18	20	22	24	26	28	30		8	10	12	14	16	18	20	22	24	26	28	30					
1													1																	
2													2	2.15	2.30	2.45	2.50	Foundations greater than 2.5m deep to be engineer designed												
3	2.40	2.50											3	1.70	1.95	2.15	2.25	2.35	2.45	2.50										
4	2.20	2.35	2.45										4	1.25	1.60	1.85	2.00	2.15	2.25	2.30	2.40	2.45	2.50	2.50						
5	1.95	2.20	2.30	2.40	2.50								5	0.90	1.25	1.55	1.75	1.95	2.05	2.15	2.20	2.30	2.35	2.40	2.45	2.45				
6	1.75	2.00	2.20	2.30	2.40	2.45	2.50						6		0.90	1.25	1.50	1.70	1.85	1.95	2.05	2.15	2.20	2.25	2.30	2.30				
7	1.55	1.85	2.05	2.20	2.30	2.35	2.45	2.50					7			1.00	1.25	1.50	1.65	1.80	1.90	2.00	2.10	2.15	2.20	2.20				
8	1.35	1.70	1.90	2.05	2.20	2.25	2.35	2.40	2.45	2.50			8			0.90	1.00	1.25	1.45	1.60	1.75	1.85	1.95	2.00	2.10					
9	1.15	1.50	1.75	1.95	2.10	2.20	2.25	2.35	2.40	2.45	2.50	2.50	9				0.90	1.05	1.25	1.45	1.60	1.70	1.80	1.90	1.95					
10	0.90	1.35	1.60	1.80	1.95	2.10	2.20	2.25	2.30	2.35	2.40	2.45	10					0.90	1.10	1.25	1.45	1.55	1.65	1.75	1.85					
11	0.90	1.15	1.50	1.70	1.85	2.00	2.10	2.20	2.25	2.30	2.35	2.40	11						0.90	1.10	1.25	1.40	1.55	1.65	1.75					
12	0.90	1.00	1.35	1.60	1.75	1.90	2.00	2.10	2.20	2.25	2.30	2.35	12							0.90	1.10	1.25	1.40	1.50	1.60					
13		0.90	1.20	1.45	1.65	1.80	1.95	2.05	2.10	2.20	2.25	2.30	13								0.90	0.95	1.10	1.25	1.40	1.50				
14		0.90	1.05	1.35	1.55	1.70	1.85	1.95	2.05	2.10	2.20	2.25	14									0.90	1.00	1.15	1.25	1.40				
15			0.90	1.20	1.45	1.60	1.75	1.85	1.95	2.05	2.10	2.20	15										0.90	1.00	1.15	1.25				
16			0.90	1.10	1.35	1.55	1.70	1.80	1.90	2.00	2.05	2.10	16											0.90	1.00	1.15				
17			0.90	1.00	1.25	1.45	1.60	1.70	1.85	1.90	2.00	2.05	17												0.90	1.05				
18				0.90	1.15	1.35	1.50	1.65	1.75	1.85	1.95	2.00	18													0.90				
19				0.90	1.05	1.25	1.40	1.55	1.70	1.80	1.90	1.95	19																	
20					0.90	1.15	1.35	1.50	1.60	1.75	1.80	1.90	20																	
21					0.90	1.05	1.25	1.40	1.55	1.65	1.75	1.85	21																	
22					0.90	0.95	1.15	1.35	1.50	1.60	1.70	1.80	22																	
23						0.90	1.10	1.25	1.40	1.55	1.65	1.75	23																	
24						0.90	1.00	1.20	1.35	1.45	1.60	1.70	24																	
25							0.90	1.10	1.25	1.40	1.50	1.60	25																	
26							0.90	1.05	1.20	1.35	1.45	1.55	26																	
27							0.90	0.95	1.15	1.30	1.40	1.50	27																	
28								0.90	1.05	1.20	1.35	1.45	28																	
29								0.90	1.00	1.15	1.30	1.40	29																	
30									0.90	1.10	1.20	1.35	30																	
31									0.90	1.00	1.15	1.30	31																	
32									0.90	0.95	1.10	1.25	32																	
33										0.90	1.05	1.15	33																	
34										0.90	1.00	1.10	34																	
35											0.90	1.05	35																	
36												0.90	1.00	36																
37												0.90	0.95	37																
38													0.90	38																

4.2

0.9m minimum foundation depth

0.9m minimum foundation depth

Table 15: MEDIUM volume change potential soil and MODERATE water demand tree

Broad-leafed trees													Coniferous												
Foundation depth (m)													Foundation depth (m)												
Distance D (m)	Tree height H (m)												Distance D (m)	Tree height H (m)											
	8	10	12	14	16	18	20	22	24	26	28	30		8	10	12	14	16	18	20	22	24	26	28	30
1	1.85	1.85	1.90	1.90	1.95	1.95	1.95	1.95	1.95	1.95	1.95	1.95	1	1.65	1.70	1.75	1.80	1.80	1.85	1.85	1.90	1.90	1.90	1.90	
2	1.65	1.75	1.80	1.80	1.85	1.85	1.85	1.90	1.90	1.90	1.90	1.90	2	1.25	1.40	1.50	1.55	1.65	1.65	1.70	1.75	1.75	1.80	1.80	
3	1.45	1.60	1.65	1.70	1.75	1.80	1.80	1.80	1.85	1.85	1.85	1.85	3	0.90	1.10	1.25	1.35	1.45	1.50	1.55	1.60	1.65	1.65	1.70	
4	1.30	1.45	1.55	1.60	1.65	1.70	1.75	1.75	1.80	1.80	1.80	1.80	4		0.90	0.95	1.10	1.25	1.30	1.40	1.45	1.50	1.55	1.60	
5	1.10	1.30	1.40	1.50	1.55	1.60	1.65	1.70	1.70	1.75	1.75	1.80	5			0.90	0.90	1.05	1.15	1.25	1.30	1.35	1.40	1.45	
6	0.90	1.15	1.30	1.40	1.45	1.55	1.60	1.60	1.65	1.70	1.70	1.75	6				0.90	0.95	1.10	1.15	1.25	1.30	1.35	1.40	
7	0.90	1.00	1.15	1.30	1.40	1.45	1.50	1.55	1.60	1.65	1.65	1.70	7					0.90	0.90	1.00	1.10	1.15	1.25	1.30	
8		0.90	1.05	1.20	1.30	1.35	1.45	1.50	1.55	1.55	1.60	1.65	8						0.90	0.95	1.05	1.10	1.20		
9			0.90	1.10	1.20	1.30	1.35	1.40	1.45	1.50	1.55	1.60	9							0.90	0.95	1.00	1.10		
10				0.90	0.95	1.10	1.20	1.30	1.35	1.40	1.45	1.50	1.55	10								0.90	0.90	0.95	
11					0.90	1.00	1.10	1.20	1.30	1.35	1.40	1.45	1.50	11										0.90	
12						0.90	1.05	1.15	1.20	1.30	1.35	1.40	1.45	12											
13							0.90	0.95	1.05	1.15	1.25	1.30	1.35	1.40	13										
14								0.90	1.00	1.10	1.15	1.25	1.30	1.35	14										
15									0.90	1.00	1.10	1.15	1.25	1.30	15										
16										0.90	0.95	1.05	1.10	1.20	1.25	16									
17											0.90	1.00	1.10	1.15	1.20	17									
18												0.90	1.00	1.10	1.15	18									
19													0.90	0.95	1.00	1.10	19								
20														0.90	0.95	1.05	20								
21																	0.90	1.00							
22																		0.90	0.95						
23																			0.90						

Table 16: MEDIUM volume change potential soil and LOW water demand tree

Broad-leafed trees												
Foundation depth (m)												
Distance D (m)	Tree height H (m)											
	8	10	12	14	16	18	20	22	24	26	28	30
1	1.35	1.40	1.40	1.45	1.45	1.45	1.45	1.45	1.45	1.45	1.50	1.50
2	1.20	1.30	1.30	1.35	1.35	1.40	1.40	1.40	1.40	1.45	1.45	1.45
3	1.05	1.15	1.20	1.25	1.30	1.30	1.35	1.35	1.35	1.40	1.40	1.40
4	0.90	1.05	1.10	1.20	1.20	1.25	1.30	1.30	1.30	1.35	1.35	1.35
5		0.90	1.00	1.10	1.15	1.20	1.20	1.25	1.25	1.30	1.30	1.30
6			0.90	1.00	1.05	1.10	1.15	1.20	1.20	1.25	1.25	1.30
7				0.90	1.00	1.05	1.10	1.15	1.15	1.20	1.20	1.25
8					0.90	1.00	1.05	1.10	1.10	1.15	1.20	1.20
9						0.90	1.00	1.05	1.05	1.10	1.15	1.15
10							0.90	0.95	1.00	1.05	1.10	1.10
11								0.90	0.95	1.00	1.05	1.10
12									0.90	0.95	1.00	1.05
13										0.90	0.95	1.00
14											0.90	0.95
15												0.90

Table 17: LOW volume change potential soil and HIGH water demand tree

Broad-leafed trees													Coniferous												
Foundation depth (m)													Foundation depth (m)												
Distance D (m)	Tree height H (m)												Distance D (m)	Tree height H (m)											
	8	10	12	14	16	18	20	22	24	26	28	30		8	10	12	14	16	18	20	22	24	26	28	30
1	2.35	2.40	2.40	2.40	2.45	2.45	2.45	2.45	2.45	2.45	2.45	2.45	1	2.15	2.25	2.30	2.30	2.35	2.35	2.35	2.40	2.40	2.40	2.40	
2	2.15	2.25	2.30	2.30	2.35	2.35	2.40	2.40	2.40	2.40	2.40	2.45	2	1.80	1.95	2.05	2.10	2.15	2.20	2.25	2.25	2.30	2.30	2.35	
3	2.00	2.10	2.15	2.20	2.25	2.30	2.30	2.35	2.35	2.35	2.35	2.40	3	1.45	1.65	1.80	1.90	1.95	2.05	2.10	2.10	2.15	2.20	2.25	
4	1.80	1.95	2.05	2.10	2.15	2.20	2.25	2.25	2.30	2.30	2.30	2.35	4	1.05	1.35	1.55	1.70	1.80	1.85	1.95	2.00	2.05	2.10	2.15	
5	1.65	1.80	1.95	2.00	2.10	2.15	2.15	2.20	2.25	2.25	2.25	2.30	5	0.75	1.05	1.30	1.50	1.60	1.70	1.80	1.85	1.90	1.95	2.00	
6	1.45	1.70	1.80	1.90	2.00	2.05	2.10	2.15	2.15	2.20	2.20	2.25	6	0.75	1.05	1.25	1.45	1.55	1.65	1.70	1.80	1.85	1.90	1.95	
7	1.30	1.55	1.70	1.80	1.90	2.00	2.05	2.05	2.10	2.15	2.15	2.20	7	0.75	0.80	1.05	1.25	1.40	1.50	1.60	1.65	1.75	1.80	1.85	
8	1.10	1.40	1.60	1.70	1.80	1.90	1.95	2.00	2.05	2.10	2.10	2.15	8	0.75	0.85	1.05	1.20	1.35	1.45	1.55	1.60	1.70	1.75		
9	0.95	1.25	1.45	1.60	1.75	1.80	1.90	1.95	2.00	2.05	2.05	2.10	9	0.75	0.90	1.05	1.20	1.35	1.45	1.50	1.60	1.65			
10	0.75	1.10	1.35	1.50	1.65	1.75	1.80	1.90	1.95	2.00	2.00	2.05	10	0.75	0.90	1.05	1.20	1.30	1.40	1.50	1.55				
11	0.75	1.00	1.20	1.40	1.55	1.65	1.75	1.80	1.90	1.95	1.95	2.00	11	0.75	0.90	1.05	1.20	1.30	1.35	1.45					
12	0.75	0.85	1.10	1.30	1.45	1.60	1.70	1.75	1.80	1.85	1.90	1.95	12	0.75	0.95	1.05	1.15	1.25	1.35						
13	0.75	1.00	1.20	1.40	1.50	1.60	1.70	1.75	1.80	1.85	1.90	13	0.75	0.80	0.95	1.05	1.15	1.25							
14	0.75	0.90	1.10	1.30	1.45	1.55	1.65	1.70	1.75	1.80	1.85	14	0.75	0.80	0.95	1.05	1.15								
15	0.75	1.00	1.20	1.35	1.45	1.55	1.65	1.70	1.75	1.80	15	0.75	0.85	0.95	1.05										
16	0.75	0.90	1.10	1.30	1.40	1.50	1.60	1.65	1.70	1.75	16	0.75	0.85	0.95											
17	0.75	0.80	1.05	1.20	1.35	1.45	1.55	1.60	1.65	1.75	17	0.75	0.85	0.95											
18	0.75	0.95	1.10	1.25	1.35	1.45	1.55	1.60	1.70	18	0.75	0.85	0.95												
19	0.75	0.85	1.05	1.20	1.30	1.40	1.50	1.55	1.65	19	0.75	0.85	0.95												
20	0.75	0.95	1.10	1.25	1.35	1.45	1.50	1.60	20	0.75	0.85	0.95													
21	0.75	0.90	1.05	1.20	1.30	1.40	1.45	1.55	21	0.75	0.85	0.95													
22	0.75	0.80	1.00	1.10	1.25	1.35	1.40	1.50	22	0.75	0.85	0.95													
23	0.75	0.90	1.05	1.20	1.30	1.35	1.45	23	0.75	0.85	0.95														
24	0.75	0.85	1.00	1.10	1.25	1.30	1.40	24	0.75	0.85	0.95														
25	0.75	0.95	1.05	1.15	1.25	1.35	25	0.75	0.85	0.95															
26	0.75	0.85	1.00	1.10	1.20	1.30	26	0.75	0.85	0.95															
27	0.75	0.80	0.95	1.05	1.15	1.25	27	0.75	0.85	0.95															
28	0.75	0.90	1.00	1.10	1.20	28	0.75	0.85	0.95																
29	0.75	0.85	0.95	1.05	1.15	29	0.75	0.85	0.95																
30	0.75	0.90	1.00	1.10	30	0.75	0.85	0.95																	
31	0.75	0.85	0.95	1.05	31	0.75	0.85	0.95																	
32	0.75	0.80	0.90	1.05	32	0.75	0.85	0.95																	
33	0.75	0.85	1.00	33	0.75	0.85	0.95																		
34	0.75	0.80	0.95	34	0.75	0.85	0.95																		
35	0.75	0.90	35	0.75	0.85	0.95																			
36	0.75	0.85	36	0.75	0.85	0.95																			
37	0.75	0.80	37	0.75	0.80	0.95																			
38	0.75	38	0.75	0.80	0.95																				

4.2

0.75m minimum foundation depth

0.75m minimum foundation depth

Table 18: LOW volume change potential soil and MODERATE water demand tree

Broad-leafed trees													Coniferous												
Foundation depth (m)													Foundation depth (m)												
Distance D (m)	Tree height H (m)												Distance D (m)	Tree height H (m)											
	8	10	12	14	16	18	20	22	24	26	28	30		8	10	12	14	16	18	20	22	24	26	28	30
1	1.50	1.50	1.55	1.55	1.55	1.55	1.55	1.55	1.55	1.60	1.60	1.60	1	1.30	1.40	1.40	1.45	1.45	1.50	1.50	1.50	1.50	1.55	1.55	
2	1.35	1.40	1.45	1.45	1.50	1.50	1.50	1.50	1.55	1.55	1.55	1.55	2	1.00	1.15	1.20	1.25	1.30	1.35	1.40	1.40	1.40	1.45	1.45	
3	1.20	1.30	1.35	1.40	1.40	1.45	1.45	1.45	1.50	1.50	1.50	1.50	3	0.75	0.90	1.00	1.10	1.15	1.20	1.25	1.30	1.30	1.35	1.35	
4	1.05	1.15	1.25	1.30	1.35	1.35	1.40	1.40	1.45	1.45	1.45	1.45	4		0.75	0.80	0.95	1.00	1.10	1.15	1.20	1.20	1.25	1.25	
5	0.90	1.05	1.15	1.20	1.25	1.30	1.35	1.35	1.40	1.40	1.40	1.40	5			0.75	0.75	0.85	0.95	1.00	1.05	1.10	1.10	1.15	
6	0.75	0.95	1.05	1.15	1.20	1.25	1.30	1.30	1.35	1.35	1.40	1.40	6				0.75	0.80	0.90	0.95	1.00	1.05	1.10	1.15	
7	0.75	0.85	0.95	1.05	1.10	1.20	1.20	1.25	1.30	1.30	1.35	1.35	7					0.75	0.75	0.85	0.90	0.95	1.00	1.05	
8		0.75	0.85	0.95	1.05	1.10	1.15	1.20	1.25	1.25	1.30	1.30	8						0.75	0.80	0.85	0.95	0.95	0.95	
9			0.75	0.90	1.00	1.05	1.10	1.15	1.20	1.25	1.25	1.30	9							0.75	0.80	0.85	0.90	0.90	
10				0.75	0.80	0.90	1.00	1.05	1.10	1.15	1.20	1.25	10									0.75	0.75	0.80	
11					0.75	0.85	0.95	1.00	1.05	1.10	1.15	1.20	11											0.75	
12						0.75	0.85	0.95	1.00	1.05	1.10	1.15	12												
13							0.75	0.80	0.90	0.95	1.00	1.05	13												
14								0.75	0.85	0.90	0.95	1.00	14												
15									0.75	0.85	0.90	0.95	15												
16										0.75	0.80	0.85	16												
17											0.75	0.80	17												
18												0.75	18												
19													19												
20													20												
21													21												
22													22												
23													23												

Table 19: LOW volume change potential soil and LOW water demand tree

Broad-leafed trees												
Foundation depth (m)												
Distance D (m)	Tree height H (m)											
	8	10	12	14	16	18	20	22	24	26	28	30
1	1.10	1.15	1.15	1.15	1.15	1.15	1.20	1.20	1.20	1.20	1.20	1.20
2	1.00	1.05	1.05	1.10	1.10	1.10	1.15	1.15	1.15	1.15	1.15	1.15
3	0.90	0.95	1.00	1.05	1.05	1.05	1.10	1.10	1.10	1.10	1.10	1.15
4	0.75	0.85	0.90	0.95	1.00	1.00	1.05	1.05	1.05	1.10	1.10	1.10
5		0.75	0.85	0.90	0.95	0.95	1.00	1.00	1.05	1.05	1.05	1.05
6			0.75	0.85	0.90	0.90	0.95	0.95	1.00	1.00	1.05	1.05
7				0.75	0.85	0.85	0.90	0.95	0.95	1.00	1.00	1.00
8					0.75	0.80	0.85	0.90	0.90	0.95	0.95	1.00
9						0.75	0.80	0.85	0.90	0.90	0.95	0.95
10							0.75	0.80	0.85	0.85	0.90	0.90
11								0.75	0.80	0.85	0.85	0.90
12									0.75	0.80	0.85	0.85
13										0.75	0.80	0.85
14											0.75	0.80
15												0.75

4.2.14 Worked example

The following is an example of how to determine foundation depths using the information in this chapter. The process may be repeated to allow the foundation to be stepped as its distance from the tree increases.

Step 1

Determine the volume change potential of the soil. Ensure the site investigation includes representative sampling and testing.

Site at Oxford, building near a Lombardy poplar (to be retained) and a sycamore (to be removed).

From laboratory tests:

Plasticity Index, $I_p = 36\%$

Test results also report that 100% of particles are smaller than $425\mu\text{m}$.

Therefore:

Modified Plasticity Index, $I'_p = \frac{36 \times 100}{100} = 36\%$

Volume change potential = medium

(In the absence of tests, assume high volume change potential).

This example is typical of Oxford clay. More than 35% of the particles are smaller than $60\mu\text{m}$ and therefore the soil is shrinkable. 100% of the particles are smaller than $425\mu\text{m}$ and therefore I'_p is the same as the I_p .

A typical boulder clay also has more than 35% of particles smaller than $60\mu\text{m}$ and is therefore also shrinkable. However, it may have only 80% of its particles smaller than $425\mu\text{m}$, in which case, the I'_p is 80% of the I_p .

A typical clayey sand may have less than 30% of its particles smaller than $60\mu\text{m}$, in which case, the soil would be non-shrinkable.

Step 2

Establish the species, mature height and water demand of all trees and hedgerows within the influencing radii.

Lombardy poplar	Sycamore
Mature height = 25m Water demand = high	Mature height = 22m Water demand = moderate

Step 3

Plot the trees and hedgerows relative to the foundations and draw their zones of influence to determine which trees will affect the foundation design. Use a scaled plan.

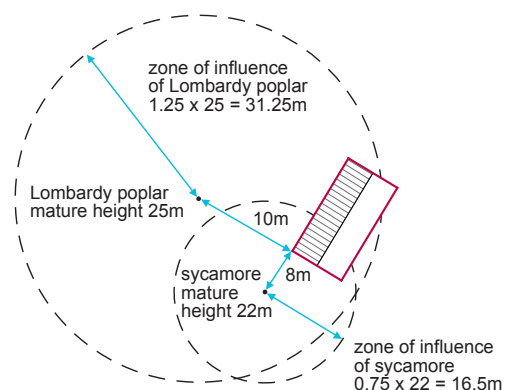

Step 4

Establish the appropriate tree height H to use.

Always use the mature height for remaining and proposed trees and hedgerows. The appropriate height to use for removed trees and hedgerows depends on the actual height when they are removed.

Lombardy poplar	Sycamore
Tree to remain. Therefore: H = mature height = 25m	Tree to be removed Mature height = 22m Actual height = 15m Actual height greater than 50% mature height. Therefore: H = mature height = 22m

Step 5

Measure the distance D from the centre of the trees or hedgerows to the face of the foundation.

Lombardy poplar	Sycamore
Distance D = 10m from foundation	Distance D = 8m from foundation

Step 6

Either:

- use the NHBC Foundation Depth Calculator App, or
- select steps 6C (a) and (b) if using charts in Clause 4.2.12 to derive depths, or
- select step 6T if using tables in Clause 4.2.13.

Step 6C (a)

Calculate D/H value

Distance D from face of foundation (step 5) divided by the appropriate tree height H (Step 4).
Alternatively D/H can be obtained from Clause 4.2.12.

Lombardy poplar	Sycamore
D = 10 = D/H = 0.4 H = 25	D = 8 = D/H = 0.36 H = 22

Step 6C (b)

Determine foundation depth using the charts in Clause 4.2.12 as follows:

Volume change potential	Chart number
High	1
Medium	2
Low	3

Lombardy poplar	Sycamore
In this example, the volume change potential is medium, then from Chart 2 for broad-leaved high water demand trees at D = 0.4 H Foundation depth = 2.33m	In this example, the volume change potential is medium, then from Chart 2 for broad-leaved moderate water demand trees at D = 0.36 H Foundation depth = 1.50m

The Lombardy poplar is the tree requiring the greater depth (2.33m).

Step 6T

Determine foundation depth using the tables in 4.2.13 as follows:

Volume change potential	Tree water demand	Table number
High	High	11
	Moderate	12
	Low	13
Medium	High	14
	Moderate	15
	Low	16
Low	High	17
	Moderate	18
	Low	19

Step 7

Adjust the depth according to the climatic zone.

A reduction may be made for distance north and west of London, but the final depth should not be less than the minimum given in each chart and table.

Oxford is between 50 and 100 miles NW of London. From 4.2.5, a reduction of 0.05m is permitted.

Final foundation depth = 2.33 – 0.05 = 2.28m

4.2.15 Further information

- *BRE Digests 240, 241 and 242 'Low rise buildings on shrinkable clay soils', parts 1, 2 and 3*
- *BRE Digest 298 'The influence of trees on house foundations in clay soils'*
- *BRE Digest 412 'Desiccation in clay soils'*
- *BS 1377 'Methods of test for soils for civil engineering purposes'*
- *BS 5837 'Trees in relation to design, demolition and construction – Recommendations'*
- *BS 5930 'Code of practice for ground investigations'*
- *Tree Recognition – A Pocket Manual by Ian Richardson and Rowena Gale, Richardson's Botanical Identifications, 49/51 Whiteknights Road, Reading, Berks RG6 7BB*
- *Field Guide to the Trees of Britain and Northern Europe* by Alan Mitchell, Harper Collins
- *Glasgow geological survey maps obtainable from British Geological Survey, Nicker Hill, Keyworth, Nottingham NG12 5GG; Tel: 0115 936 3100*
- *Tree root damage to buildings Vol.1 Causes, Diagnosis and Remedy, Vol. 2 Patterns of Soil Drying in Proximity to Trees on Clay Soils by P G Biddle, Willowmead Publishing, Wantage OX12 9JA*
- *Institution of Civil Engineers*
1-7 Great George Street, London SW1P 3AA;
Tel: 020 7222 7722; www.ice.org.uk
- *Institution of Structural Engineers*
47-58 Bastwick Street, London EC1V 3PS;
Tel: 020 7235 4535.

Acknowledgements: NHBC gratefully acknowledges the help given by authoritative organisations and individuals in the preparation of this chapter, particularly: Building Research Establishment; Dr P G Biddle, arboricultural consultant.



Chapter

4.3



Strip and trench fill foundations

This chapter gives guidance on meeting the Technical Requirements for strip and trench fill foundations.

4.3.1	Compliance	01
4.3.2	Provision of information	01
4.3.3	Ground conditions	01
4.3.4	Hazardous ground	02
4.3.5	Setting out	02
4.3.6	Services and drainage	03
4.3.7	Safe transmission of loads	03
4.3.8	Sloping ground and stepped foundations	05
4.3.9	Excavations	05
4.3.10	Reinforcement	06
4.3.11	Concrete	06
4.3.12	Movement joints	06
4.3.13	Construction joints	06

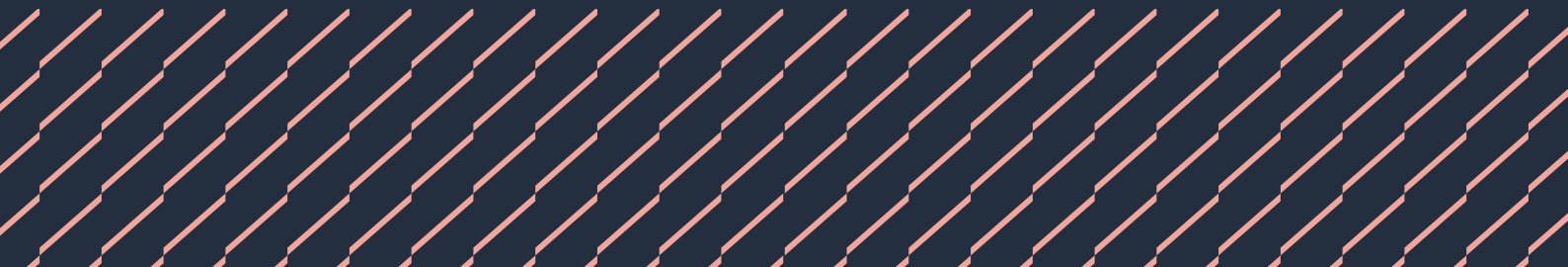

4.3.1 Compliance

Also see: Chapter 2.1

Strip and trench fill foundations shall comply with the Technical Requirements and provide adequate support to all load-bearing elements.

Strip and trench fill foundations that comply with the guidance in this chapter will generally be acceptable.

Foundations should be designed by an engineer in accordance with Technical Requirement R5 where:

- buildings exceed three storeys in height
- supporting/retaining walls form habitable rooms below ground
- trench fill foundations are deeper than 2.5m
- they will be deeper than those of an adjoining construction.

Elements of the building requiring foundations include:

- external walls
- separating (party) walls
- internal load-bearing walls
- chimney breasts
- piers.

In Scotland, a sleeper wall is defined as a load-bearing element and therefore should be provided with a suitable foundation.

In England, Wales, Northern Ireland and the Isle of Man, sleeper walls should be provided with suitable foundations where the oversite concrete is:

- cast on shrinkable clay soils where heave could take place
- cast on infill deeper than 600mm
- less than 100mm thick.

4.3.2 Provision of information

Also see: Chapter 4.1

Designs and specifications shall be produced in a clearly understandable format, include all relevant information and be distributed to all appropriate personnel.

Clear and fully detailed drawings should be available on site to enable work to be carried out in accordance with the design. Design and specification information should be issued to site supervisors, relevant specialist subcontractors and/or suppliers. All necessary dimensions and levels should be indicated and relate to at least one benchmark and reference points on the site.

Information on ground conditions, the site investigation and the foundation design may be requested by NHBC, including sites which may not be classified as hazardous.

Both designers and site operatives need to be aware of the ground conditions and any features requiring special attention, such as existing sewers or other services, the water table and the presence of any hazardous substances, including sulfates.

Where toxic materials or those likely to present a health hazard are found, all available information should be supplied to NHBC, together with proposals for remediation.

Full details of junctions, steps, movement joints and any critical sequences of construction should be provided.

4.3.3 Ground conditions

Also see: Chapters 3.2, 4.1, 4.2 and 5.2

Strip and trench fill foundations shall be adequate, of a suitable depth and taken to a suitable bearing stratum. Issues to be taken into account include:

- a) the home design and layout
- b) ground conditions
- c) frost susceptible soils and cold weather construction
- d) shrinkable and volume change soils.

The home design and layout

Foundation design should take account of site conditions, shape, size and construction of the homes. Foundations for terraced homes may require special precautions to prevent damage from differential settlement, while stepped foundations or suspended floors may be required for sloping sites.

The depth of foundations should provide a clean, firm and adequate bearing for the design loads.

Ground conditions

All relevant information about the history of the site, plus the nature and load-bearing capacity of the ground, should be available before the foundations are designed. Information may be available from:

- NHBC
- local authorities
- gas, water and electricity companies
- aerial photographs, Ordnance Survey maps and geological maps and surveys.

Site assessment surveys may require supplementary investigations involving trial pits and boreholes.

Frost susceptible soils and cold weather construction

In frost susceptible soils, eg chalk, the depth to the underside of the foundation should be at least 450mm below finished ground level, to avoid damage from frost action.

Additionally, when construction is undertaken during cold weather the foundation should either be at least 450mm below finished ground level, or alternatively, precautions should be taken to prevent freezing of the ground.

Where the finished ground level is to be above the existing ground level and cold conditions are expected, the foundation depth should be taken from the existing, not finished, ground level.

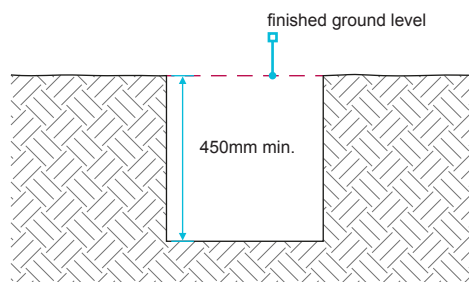

Shrinkable and volume change soil

The design should specify the minimum foundation depth.

Table 1: Minimum foundation depths in shrinkable soil

Modified Plasticity Index	Volume change potential	Minimum depth (m)
40% and greater	High	1.0
20% to less than 40%	Medium	0.9
10% to less than 20%	Low	0.75

Shrinkable soils are classified as containing more than 35% fine particles (clay and silt) and have a Modified Plasticity Index of 10% or greater.

These minimum depths may only be used where any existing or proposed trees or shrubs are outside the zone of tree influence. Heave is possible in shrinkable soil where trees have been, or are being, removed.

4.3.4 Hazardous ground

Also see: Chapters 2.1 and 4.2

Strip and trench fill foundations on hazardous ground shall be designed by an engineer, and notice given to NHBC before work commences.

Where hazardous ground has been identified, NHBC must be notified eight weeks before work starts. Hazardous ground is defined in Chapter 4.1 'Land quality – managing ground conditions'.

4.3.5 Setting out

Strip and trench fill foundations shall be set out to take account of the design details.

The accuracy of setting out should be checked by control measurements of trenches, including their location relative to site boundaries and adjacent buildings. Levels should be checked against accepted benchmarks.

For excavations, check:

- trench lengths
- trench widths
- length of diagonals between external corners.

Walls should be located centrally on the foundation, unless specifically designed otherwise.

Any discrepancy in dimensions should be reported promptly to the designer. Resulting variations should be distributed to all appropriate persons, including NHBC.

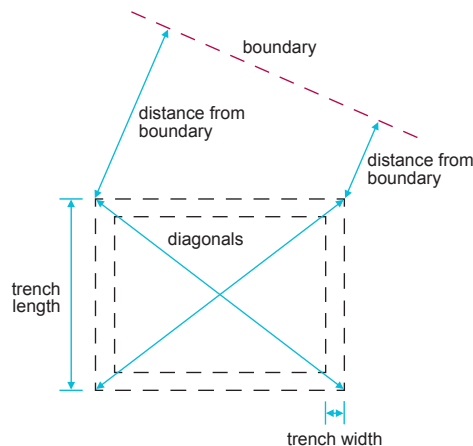

4.3.6 Services and drainage*Also see: Chapters 5.1 and 5.3***All strip and trench fill foundations shall be installed to:**

- a) adequately protect existing services and ground water drainage b) make allowance for drainage and other services.

Adequately protect existing services and ground water drainage

Any existing services, such as cables, water pipes or gas mains, may need to be supported and protected. Services should not be rigidly encased in the foundations, and drains which are redundant should be cut open and filled or removed. Precautions should be taken to accommodate the effects of settlement where drains run under, or near to, a building.

Provision should be made to divert or protect any existing ground water drains affected by excavation work.

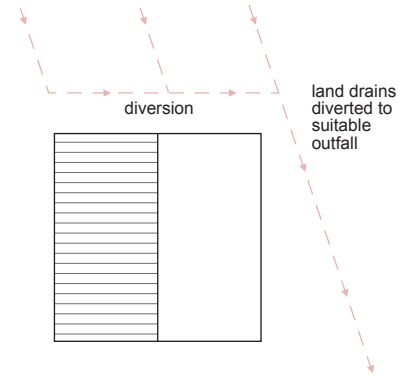
**Make allowance for drainage and other services**

Where services are to pass through or above foundations, provision should be made for suitable ducts or lintels to enable later installation.

Strip foundations

Services should not pass through strip foundations but through the masonry above. Adequate lintels should be provided in the masonry.

Trench fill

The load-bearing capability of foundations should not be affected where services pass through. Services should be either sleeved or pass through a suitably strengthened opening in the foundation. This is to ensure that differential movement will not damage services.

For drainage, it is important to leave sufficient space for movement to ensure that the drain is capable of maintaining line and gradient.

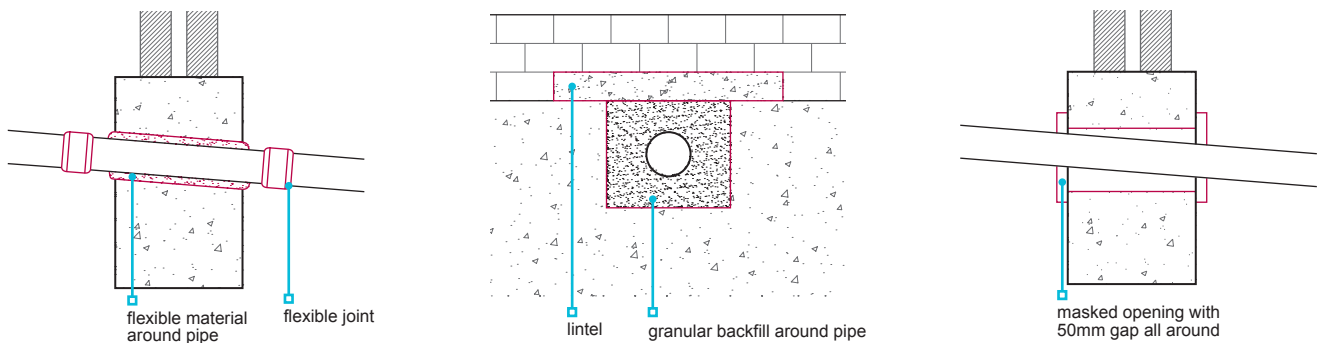
**4.3.7 Safe transmission of loads***Also see: BS 8103-1***Strip and trench fill foundations shall transmit loads to the ground safely and without excessive settlement, and take into account:**

- a) dead and imposed loads c) stability of any adjoining building.
b) foundation width and thickness

Dead and imposed loads

Dead and imposed loads should be calculated in accordance with:

BS EN 1991-1-1	UK National Annex to Eurocode 1. 'Actions on structures. General actions. Densities, self-weight, imposed loads for buildings'
BS EN 1991-1-3	UK National Annex to Eurocode 1. 'Actions on structures. General actions. Snow loads'
BS EN 1991-1-4	UK National Annex to Eurocode 1. 'Actions on structures. General actions. Wind actions'
BS 648	'Schedule of weights of building materials'

All foundations should be:

- continuous throughout the building, including integral garages, porches, conservatories, bay windows, etc
- symmetrical beneath load-bearing elements (ie, walls should be located centrally on foundations).

Foundation width and thickness

The following guidance covers the design and construction of foundations only in normal or undisturbed natural ground - ie, for which the use of strip footings or trench fill foundations using unreinforced concrete, as shown in figure below, are sufficient. For sites where hazardous conditions exist as described in clause 4.3.4 and which might require reinforced strip footings, rafts or piled foundations, the design should be undertaken by a suitably qualified person.

The width of the foundation should:

- be of sufficient width throughout to avoid overstressing the ground, especially where the foundation is required to support piers or columns
- depend on the load-bearing capacity of the subsoil and the loads from the building
- not be less than the wall thickness, plus at least 50mm each side.

The width of strip foundations should account for ground conditions and be in accordance with the following table:

Table 2: Acceptable foundation widths

Type of ground	Condition of ground	Field test applicable	Total load of load-bearing walling not more than (kN/linear metre)					
			20	30	40	50	60	70
			Minimum width of strip foundation (mm)					
Rock	Not inferior to sandstone, limestone or firm chalk	Requires at least a pneumatic or other mechanically operated pick for excavation	Equal to the width of the wall plus 50mm each side					
Gravel Sand	Medium dense	Requires pick for excavation Wooden peg 50mm square in cross-section is hard to drive beyond 150mm	250	300	400	500	600	650
Clay Sandy clay	Stiff	Can be indented slightly by thumb	250	300	400	500	600	650
Clay Sandy clay	Firm	Thumb makes impression easily	300	350	450	600	750	850
Sand Silty sand Clayey sand	Loose	Can be excavated with a spade Wooden peg 50mm square in cross-section can be easily driven	400	600	Does not fall within the provisions of this guidance where the total load exceeds 30 kN/linear m			
Silt Clay Sandy clay Clay or silt	Soft	Finger can be pushed in up to 10mm	450	650				
Silt Clay Sandy clay Clay or silt	Very soft	Finger can be easily pushed in up to 25mm	Refer to specialist advice					

The thickness (T) of the foundation should be:

- equal to projection (P) or 150mm (whichever is greater)
- 150mm to 500mm for strip foundation
- 500mm minimum for trench fill foundations.

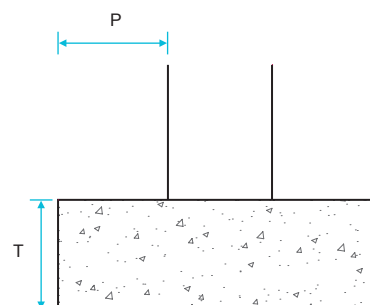

4.3.10 Reinforcement

Also see: Chapter 3.1

Reinforcement for strip and trench fill foundations shall ensure the safe transfer of loads and be suitable for localised ground conditions.

Reinforcement should be:

- appropriately sized
- placed correctly
- clean and free from loose rust
- secured at laps and crossings
- supported to ensure that they are 75mm above the base of the foundation or as indicated in the design.

If in doubt about any soft spots, the designer's advice should be taken before placing the concrete.

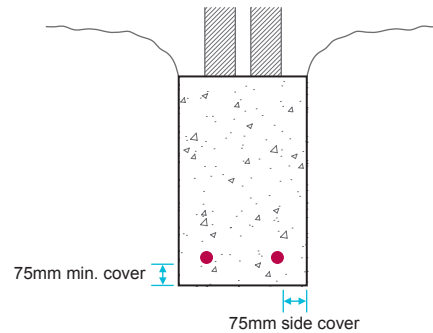

4.3.11 Concrete

Also see: Chapters 3.1 and 3.2

Concrete for foundations shall be:

- a) of a mix which is suitable for the intended use
- b) durable against chemical or frost action
- c) correctly mixed, placed and cured.

Concreting should be carried out, as far as possible, in one operation, taking account of weather conditions and available daylight. Concrete should be placed as soon as possible after the excavation has been checked.

For trench fill foundations, it is particularly important to check that the finished level is correct and horizontal, as it is difficult to adjust for discrepancies in the small number of brick courses between the foundation and the DPC.

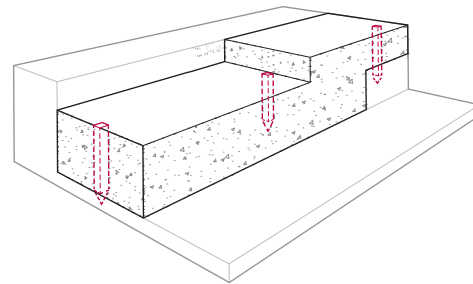

pegs used to ensure correct levels

4.3.12 Movement joints

Strip and trench fill foundations shall have movement joints suitable for their intended purpose.

Where movement joints are specified, they should be continuous with those in the superstructure.

4.3.13 Construction joints

Construction joints in strip and trench fill foundations shall be suitably formed.

Where construction joints are unavoidable:

- they should not be positioned near a return in the foundation beyond the construction joint
- all shuttering should be removed before work continues.

Construction joints for strip and trench fill foundations may be formed by one of the methods shown below:

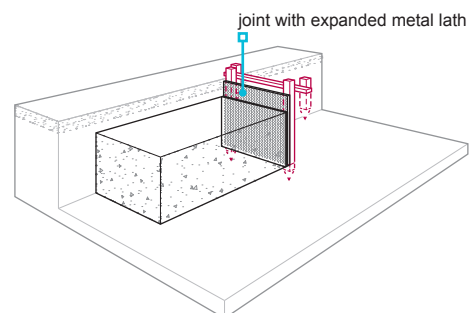
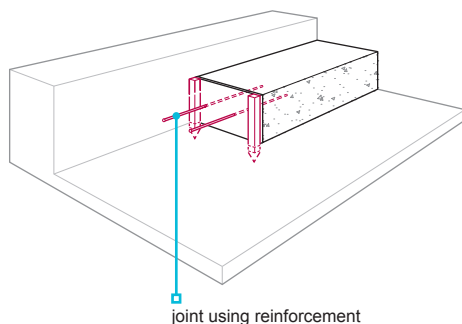



Chapter

4.4



Raft, pile, pier and beam foundations

This chapter gives guidance on meeting the Technical Requirements for raft, pile, pier and beam foundations.

4.4.1	Compliance	01
4.4.2	Provision of information	01
4.4.3	Site conditions	01
4.4.4	Hazardous ground	02
4.4.5	Services and drainage	02
4.4.6	Safe transmission of loads	03
4.4.7	Construction	03
4.4.8	Engineer checks	05
4.4.9	Compressible materials	05
4.4.10	Reinforcement	05
4.4.11	Concrete	05
4.4.12	Movement joints	05
4.4.13	Resistance to moisture	06

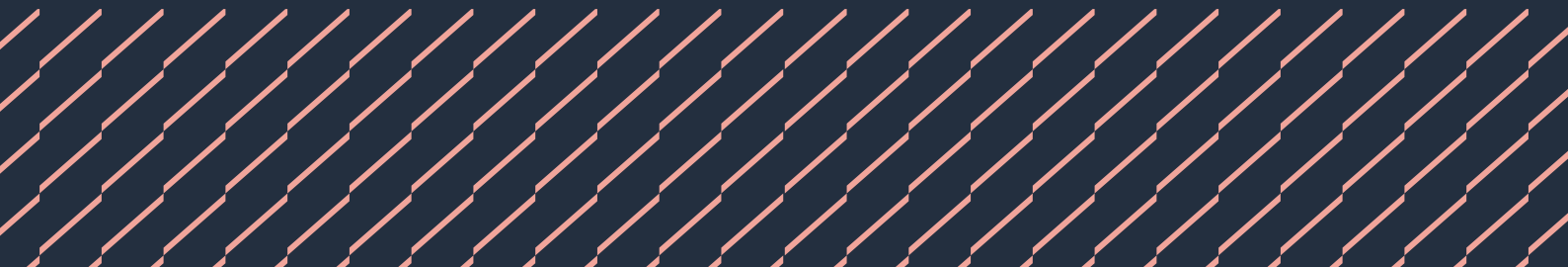

4.4.1 Compliance

Also see: Chapter 2.1

Raft, pile, pier and beam foundations shall comply with the Technical Requirements and provide adequate support to load-bearing elements.

Raft, pile, pier and beam foundations that comply with the guidance in this chapter will generally be acceptable.

Relevant Standards and codes of practice include:

BS 8004	'Code of Practice for foundations'
BS EN 1991	'Actions on structures'
BS EN 1992	'Design of concrete structures'
BS EN 1997-1	'Geotechnical design. General rules'
BS 10175	'Investigation of potentially contaminated sites. Code of practice'

Elements of the building requiring foundations include:

- external walls
- separating (party) walls
- internal load-bearing walls
- chimney breasts
- piers
- sleeper walls
- internal masonry walls.

4.4.2 Provision of information

Designs and specifications shall be produced in a clearly understandable format, include all relevant information and be distributed to all appropriate personnel.

All dimensions and levels should be indicated and relate to at least one benchmark and reference points on site. Design and specification information should be issued to site supervisors, relevant specialist subcontractors and/or suppliers, and include the following information:

- dimensions, type and depth of foundations
- detailing of ducts
- junctions
- steps
- movement and construction joints
- location of services
- critical sequences of construction.

Both designers and site operatives need to be aware of:

- ground conditions
- any features requiring special attention, such as existing sewers or other services
- water table levels
- the presence of any hazardous substances including sulfates.

4.4.3 Site conditions

Also see: Chapters 5.2 and 4.1

Raft, pile, pier and beam foundations shall be designed to take account of site conditions. Issues to be taken into account include:

- | | |
|---|---|
| a) the results of the site and ground appraisal | d) frost susceptible soils |
| b) dwelling design, layout and site levels | e) potential for differential settlement. |
| c) trees and hedges | |

Site and ground appraisal

All information relating to the site and its ground conditions which is necessary for full and proper foundation design should be obtained.

Building over changes in ground characteristics should be avoided.

Dwelling design, layout and site levels

Foundation design should take account of site layout, shape, size and construction of the dwelling.

Stepped foundations and suspended floors may be required for sloping sites.

Trees and hedges

Where the soil is shrinkable and nearby trees and hedges are existing, proposed or have been recently removed, foundations should be designed as shown in Chapter 4.2 'Building near trees'.

Frost susceptible soils

To avoid damage from frost action, the depth to the underside of the foundation in frost susceptible ground should be at least 450mm below finished ground level.

Differential settlement

Foundations should be designed to avoid any local stress points or any differential settlement.

Foundations for terraced homes, or those adjoining an existing building, may require special precautions to prevent damage from differential settlement. Foundations for attached bays, porches, garages, conservatories and other structures should be a continuation of those for the main home, unless the design indicates an alternative which takes account of differential movement.

4.4.4 Hazardous ground

Also see: Chapters 3.1, 4.1, 4.2 and BRE Special Digest 1

Raft, pile, pier and beam foundations shall take account of ground conditions and hazards. Where hazardous ground has been identified, notice shall be given to NHBC before work commences.

Where there is hazardous ground, the design of foundations must be carried out by an engineer in accordance with Technical Requirement R5.

Where hazardous ground has been identified, NHBC should be notified in writing at least eight weeks before work on site begins, in accordance with NHBC Rules.

Where toxic materials, or those likely to present a health hazard are found, all available information should be supplied to NHBC, together with proposals for remediation.

Sulfate and acids

Sulfates and other chemicals can cause expansion and disruption of concrete. High acidity, for example in peat, or permeable soil with acidic ground water can cause damage to concrete. Where sulfates or high acidity in ground or ground water are present, reference should be made to Chapter 3.1 'Concrete and its reinforcement' for guidance concerning acceptable concrete mixes.

Where concrete is at risk from chemical attack from the ground, or where the ground water is highly mobile, the level of sulfate and other chemicals should be determined in terms of the ACEC class (aggressive chemical environment for concrete class), in accordance with BRE Special Digest 1.

4.4.5 Services and drainage

Also see: Chapters 5.1, 5.3 and 8.1

Raft, pile, pier and beam foundations shall take account of new and existing services. Issues to be taken into account include:

- a) provision for new services
- b) adequate protection of existing services and drainage.

Provision for new services

Where services are to pass through, above or under foundations, openings should be provided using suitable ducts, sleeves or lintels that:

- are detailed so as not to impair structural stability
- do not affect the ability of the foundation to carry loads
- make suitable provision to allow for movement
- have sufficient space to maintain line and gradient of drainage where movement occurs.

Existing services and drainage

Existing services or drains should:

- be supported and protected
- be bridged, to prevent any load carrying
- not be rigidly encased in concrete, masonry, etc.

Land drains should be diverted to a suitable outfall; other drains should be diverted or bridged.

4.4.6 Safe transmission of loads*Also see: Chapter 4.6*

Raft, pile, pier and beam foundations shall be designed to transmit loads from the structure to the ground safely, without excessive settlement.

Raft, pile, pier and beam foundations should safely transmit loads. The following issues should be taken into account:

- adequate stiffness to ensure that differential movement does not adversely affect the supported structure
- nature and bearing capacity of the fill material to be placed under the foundation
- specification of concrete and cover to reinforcement.

Raft and semi-raft foundations:

Raft and semi-raft foundations should be designed:

- to prevent the erosion of ground beneath the raft
- (where required) to accommodate warm air ducts, service ducts or services without any adverse effect upon the performance of the foundation
- to limit the risk of ducts becoming flooded
- to support the building envelope without the risk of differential movement between leaves of cavity walls.

Fill for raft foundations should be in accordance with Chapter 4.6 'Engineered fill'.

Semi-raft foundations on engineered fill:

The following notes are to be used as a guide for engineers designing raft foundations, but are by no means exhaustive. Special consideration will be required for certain sites.

- raft foundations are to be designed by a chartered civil or structural engineer taking account of ground conditions and the results of the site appraisal and ground assessment
- sufficient internal beams are to be provided to stiffen the slab adequately
- the area between downstand beams should not be greater than 35m²
- the ratio of adjacent sides on plan should not exceed 2:1
- the minimum depth of perimeter and party wall beams is to be 450mm. On larger homes, some internal beams should be of the same depth as the perimeter beams
- perimeter and internal beams should be sufficiently wide at their base to carry their total loading at the allowable bearing pressure for the site
- beams are to be designed to span 3m simply supported and cantilever 1.5m
- beams are to use properly formed reinforcement in accordance with BS EN 1992-1-1
- where mesh is used in beams, it should be delivered to the site pre-bent
- all beams should be cast on a minimum of 50mm concrete blinding
- minimum cover to reinforcement should be 40mm
- floor slabs should be a minimum 150mm thick, with nominal top face reinforcement as a minimum and anti-crack reinforcement in the bottom face, where appropriate
- stools or similar should be used to support floor slab mesh during casting
- corners and junctions to beams should be adequately tied using similar reinforcement to the beams
- a minimum cavity drain of 225mm below the DPC is to be maintained.

Piled foundations:

The design of all piled foundations should specify precautions for cohesive soils where volume changes can occur.

The bearing capacity and integrity of piles should be confirmed by testing, when required.

4.4.7 Construction*Also see: Chapter 4.2*

Raft, pile, pier and beam foundations shall be constructed in accordance with the design. Issues to be taken into account include:

- | | |
|---|--|
| a) setting out and excavations | c) installation of piles, piers and ground beams |
| b) localised effects and trench bottoms | d) load capacity verification of piles. |

Setting out and excavations

The accuracy of setting out should be checked by control measurements of trenches, including their location relative to site boundaries and adjacent buildings. Levels should be checked against benchmarks, where appropriate. For excavations, check:

- trench lengths
- trench widths
- length of diagonals between external corners.

In addition, for piled, pier and beam foundations, check:

- spacing
- alignment
- positions in relation to the proposed superstructure.

Walls should be located centrally on the foundation, unless specifically designed otherwise. Inaccuracy may prevent walls and piers being located centrally, resulting in eccentric loading and possible foundation failure.

Discrepancies to the design of the foundations or variations in the ground conditions should be reported formally to the engineer.

Variations in design or ground conditions should be recorded and distributed to NHBC and others concerned with sitework.

Foundation excavations should:

- be kept free from water
- not be excessive.

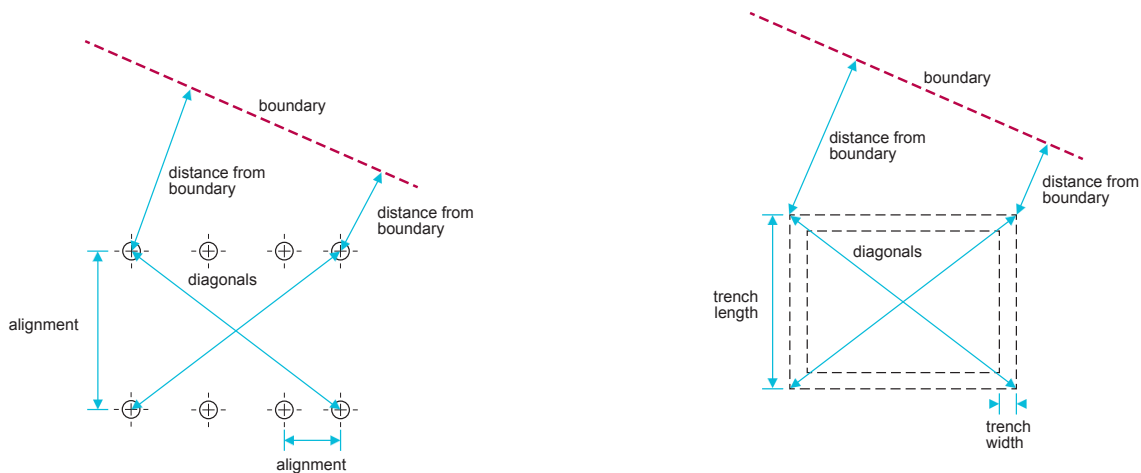

Localised effects and trench bottoms

Trench bottoms affected by rain water, ground water or drying should be rebottomed to form a sound surface.

Table 1: Localised effects

Situation	Action
Differences in bearing capacity (eg from localised changes in strata)	Consult the engineer
Soft spots	Excavations should be deepened locally to a sound bottom, or the concrete should be reinforced
Hard spots	Should be removed
Visible roots, especially in clay soils	Consult the engineer and modify the design depth

Installation of piles, piers and ground beams

Piles are to be installed by an appropriate specialist and under the supervision of an engineer.

Piles are to be vertical, unless designed otherwise.

Where piles are more than 75mm out of position, or out of alignment by more than 1:75, the engineer should reconsider the adequacy of the foundation design.

Where piles are misaligned by more than 150mm in any direction, or more than 5° from their specified rake, they should be replaced, unless otherwise recommended by the engineer. Alternatively, additional piles should be provided in accordance with the design modifications provided by the engineer.

Care should be taken to ensure that the bond of beams to piers and piles is in accordance with the design and is adequate.

Load capacity verification of piles

Test loading of piles should be undertaken when required. The builder is to obtain written confirmation that the piles are suitable for their design load.

4.4.8 Engineer checks

Engineer-designed foundations shall be inspected by the engineer during construction.

The engineer should undertake site visits to ensure that the design of the foundation is suitable for the actual ground conditions encountered, and that the construction is in accordance with the design.

4.4.9 Compressible materials

Also see: Chapter 4.2

Compressible materials shall be capable of absorbing potential heave forces.

Materials used to accommodate heave should be assessed in accordance with Technical Requirement R3 and used in accordance with the manufacturer's recommendations and independent assessment when applicable.

4.4.10 Reinforcement

Reinforcement of raft, pile, pier and beam foundations shall be in accordance with the design, sufficient to ensure the safe transfer of loads and be suitable for localised ground conditions.

Reinforcement should be:

- appropriately sized
- placed correctly
- clean and free from loose rust
- secured at laps and crossings
- properly supported to ensure that the cover indicated in the design is maintained.

Reinforcement may be necessary, for example at construction joints or over small localised soft spots or changes in bearing strata.

4.4.11 Concrete

Concrete for raft, pile, pier and beam foundations shall be:

- | | |
|--|---------------------------------------|
| a) of a suitable mix design to achieve the required strength and resistance to chemical and frost action | b) correctly mixed, placed and cured. |
|--|---------------------------------------|

Mixing, placing, testing and curing of concrete should be carried out as indicated in Chapter 3.1 'Concrete and its reinforcement' and when work is carried out in cold weather, Chapter 3.2 'Cold weather working'.

Suitable mix

Concrete should be of a mix which:

- will achieve the required strength and not impair the performance of the foundation
- is sufficiently resistant to chemical and frost action.

Correctly mixed, placed and cured

Before concrete is placed, excavations and reinforcement may need to be approved by the engineer or their representative and, in England and Wales, foundations should be approved by the person responsible for building control inspections.

Concreting should:

- be carried out in one operation (as far as possible)
- take account of weather conditions and available daylight
- be placed as soon as possible after the excavation or after the reinforcement has been checked
- be placed in even, compact and reasonably dry trenches.

4.4.12 Movement joints

Raft, pile, pier and beam foundations shall have movement joints suitable for their intended purpose, and be formed using appropriate materials.

Movement joints should be located so as to limit the risk of damage caused by movement. The design of movement joints and choice of sealing materials should consider:

- anticipated movement
- movement capability of seal
- designed joint width
- actual joint width
- joint depth
- surface preparation
- backing medium
- projected life span of the joint.

4.4.13 Resistance to moisture

Also see: Chapters 5.1, 5.2 and 5.4

Raft, pile, pier and beam foundations shall prevent the passage of moisture to the inside of the home and, where necessary, include a drained cavity and damp proof membranes.

Cavity walls should drain below the DPC and should:

- prevent water crossing from the outside to the inside
- prevent the flooding of cavities above the DPC
- have a minimum 225mm clear cavity below the DPC where strip, trenchfill or ground beams are used, or have a minimum 150mm clear cavity below the DPC where other types of foundations are used, provided that weepholes and other necessary measures are taken to ensure that the cavity can drain freely.

DPC cavity trays are not an acceptable waterproofing to the edges of specialised foundations, such as rafts and ground beams.

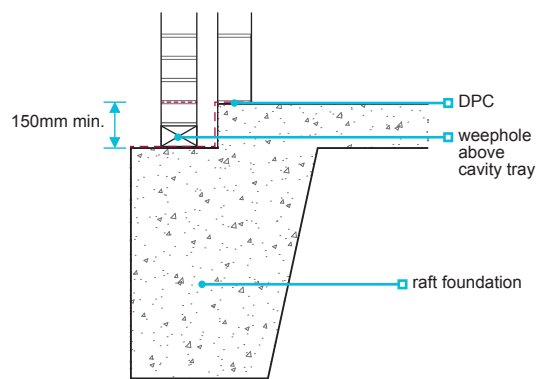
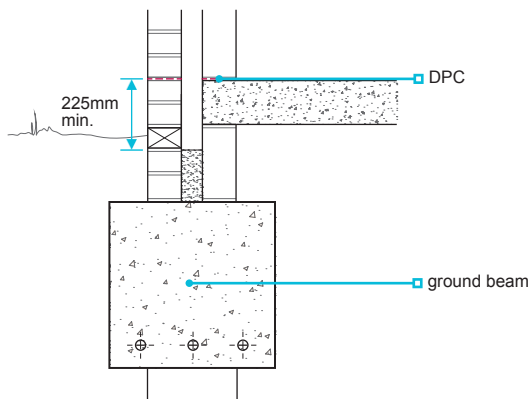



Chapter 4.5



Vibratory ground improvement techniques

This chapter gives guidance on meeting the Technical Requirements and recommendations for vibratory ground improvement techniques.

4.5.1	Compliance	01
4.5.2	Hazardous sites and ground hazards	01
4.5.3	Desk study and site investigation	01
4.5.4	Confirmation of suitability for treatment	02
4.5.5	Suitability of ground conditions	02
4.5.6	Compatibility of the ground, design and treatment	05
4.5.7	Acceptable methods	06
4.5.8	Materials for use as fill	07
4.5.9	Granular material	08
4.5.10	Sitework	08
4.5.11	Adjacent excavations	09
4.5.12	Verification of completed treatment	09

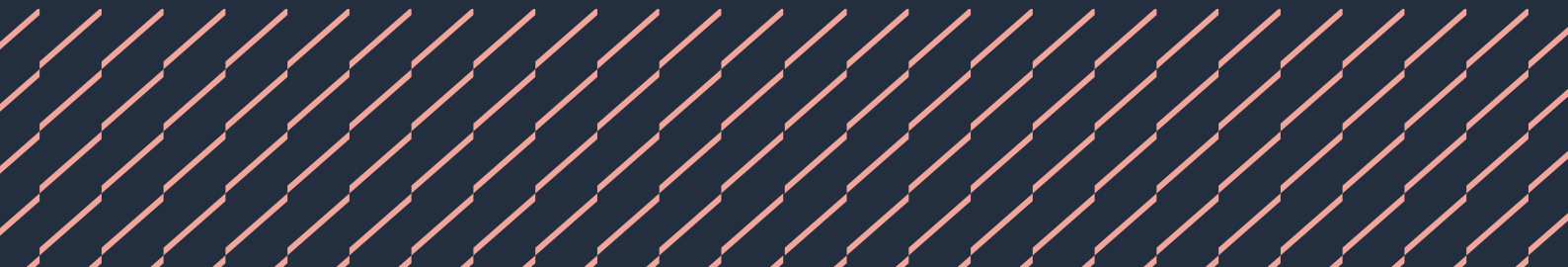

Introduction

The vibratory process is generally applied to weak natural soils and filled ground. The purpose is to improve the load-bearing capacity, reduce settlement and provide an adequate bearing stratum for the foundation supporting the home.

4.5.1 Compliance

Also see: Chapter 2.1

Vibratory ground improvement techniques shall comply with the Technical Requirements and be designed by an engineer in accordance with established standards and codes of practice.

Vibratory ground improvement techniques that comply with the guidance in this chapter, and that are in accordance with the relevant British Standards, Building Regulations and statutory requirements, will generally be acceptable.

Design of vibratory ground improvement, including foundations, should be carried out by an engineer experienced in ground improvement techniques in accordance with Technical Requirement R5. In this chapter, the term 'engineer' refers to an appropriate engineer who is independent of the contractor responsible for the vibratory ground improvement techniques.

British Standards, codes of practice and authoritative documents relevant to vibratory ground improvement techniques and site investigations include:

BS 10175	'Investigation of potentially contaminated sites – Code of practice'
BS EN 1991	'Actions on structures'
BS EN 1997-1	'General rules'
BS EN 1997-2	'Ground investigation and testing'
BS EN 14731	'Execution of special geotechnical works – Ground treatment by deep vibration'
BS EN ISO 14688	'Geotechnical investigation and testing – Identification and classification of soil'
BS EN ISO 14689	'Geotechnical investigation and testing – Identification and classification of rock'
BS EN ISO 22476	'Geotechnical investigation and testing – Field testing'
BR 391	'Specifying vibro stone columns'
ICE	'Specification for Ground Treatment'

4.5.2 Hazardous sites and ground hazards

Also see: Chapter 2.1, 4.1 and 4.2

Vibratory ground improvement techniques on hazardous sites shall be reported to NHBC before work on site commences, and be designed to take account of the characteristics of the site, including any ground hazards.

Hazardous sites, as defined in the NHBC Rules, should be reported to NHBC in writing at least eight weeks before sitework begins.

Details of ground hazards to be taken into consideration are given in Chapter 4.1 'Land quality – managing ground conditions' and Chapter 4.2 'Building near trees'.

4.5.3 Desk study and site investigation

Also see: Chapter 2.1, 4.1 and 4.2

The engineer shall ensure a desk study and site investigation are undertaken and findings used to inform the design.

The engineer should establish the scope of, and supervise, the site investigation, taking account of the findings of the desk study, and relevant standards listed in Clause 4.5.1.

The specialist contractor should be satisfied that the site investigation provides adequate and representative information in order to design the ground improvements. The results of the site investigation and desk study should be sent to NHBC prior to work starting and should, as a minimum, determine the items listed in Table 1.

Table 1: Results of the site investigation and desk study

Item to be determined	Guidance
Depths and properties of natural materials under the site	Includes the presence of caves, workings, or natural phenomena such as rocks or soils which dissolve or erode when exposed to the passage of water Data for comparison with post-treatment properties should be established
Extent and nature of any areas of filled ground on the site	Includes: <ul style="list-style-type: none"> • proportions and distribution of constituent materials • state of compaction of the fill material throughout its depth • grading and particle size distribution of fill materials • potential for gas generation from fill materials • potential for spontaneous combustion of fill and/or natural deposits
Presence and extent of any existing or redundant services and drains	Includes information on the extent and nature of the backfill to the excavations
The effect of sustainable drainage systems	Includes the effect that any sustainable drainage system (SuDS) may have on the geotechnical parameters of the site
Presence, level and nature of any ground water	Includes the potential for ground water to rise and cause heave or collapse by saturation
Previous structures	Includes any potential underground obstructions or hard-spots, eg basement walls, floor slabs, which remain
Occurrence of contaminated substances	Includes the presence and extent of contaminated substances or gases present or suspected

4.5.4 Confirmation of suitability for treatment

Also see: Chapter 2.1, 4.1 and 4.2

The builder shall obtain written confirmation from the engineer and specialist contractor that the site is suitable for the proposed ground improvement system.

NHBC should be notified prior to work starting, that the site is suitable for the proposed system. The engineer and specialist contractor should agree the following in writing before work commences on site:

- design objectives
- detailed schedule of work
- programme of work
- tests to be conducted on completion of the work
- responsibility for procedures and tests.

The following considerations should be taken into account:

- layout and depth of the stone columns and the accuracy to be achieved
- safety issues to be incorporated into the design to allow for unforeseen circumstances
- criteria for non-acceptance of the vibrating poker work tests to be conducted on completion of the work
- responsibility for procedures and tests
- calculations and case histories required to justify the ground improvement proposals together with the layout of the stone columns and details of the equipment and process to be used on site.

These written agreements should be made available to NHBC before work commences on site.

4.5.5 Suitability of ground conditions

Also see: Chapter 2.1, 4.1 and 4.2

Vibratory ground improvement techniques shall only be conducted on suitable ground and be appropriate for the site conditions. Issues to be taken into account include:

- a) unsuitable ground conditions
- b) detrimental factors
- c) ground water conditions.

The engineer should assess the ground and be satisfied that it is suitable for treatment. Conditions acceptable for treatment are only those within zones A and B of Chart 1.

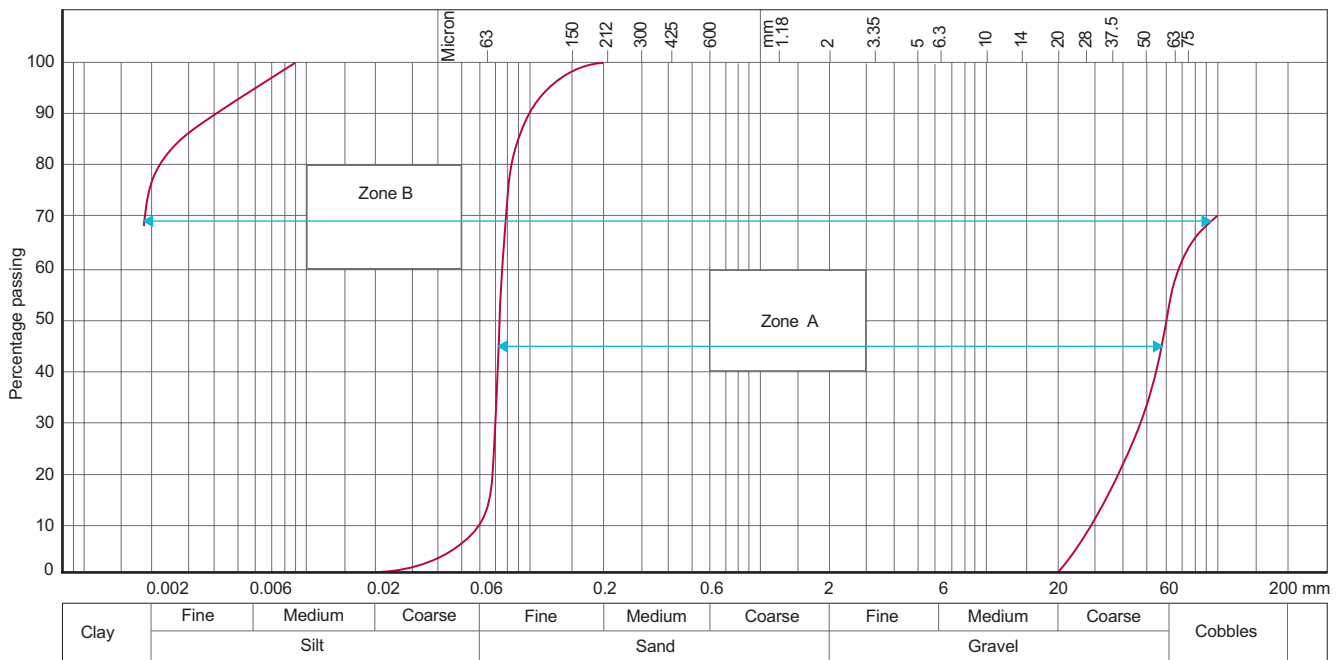
Chart 1: Conditions acceptable for treatment

Zone A – range of materials suitable for deep compaction (vibro-compaction) techniques.

Zone B – range of materials suitable for stone column (vibro-replacement) techniques.

Unsuitable ground conditions

Table 2: Ground conditions not generally acceptable for treatment

Soil composition	
Clays	Ground with a Plasticity Index greater than 40%
Soft clays	Ground with soft clays with an undrained shear strength less than 30kN/m ² For clay strength less than 30kN/m ² additional consideration must be given to group effects, ground heave and settlement due to installation. Any proposals will be subject to NHBC agreement
Ground with peat layers	Ground with peat layers close to foundation level or the base of the stone column, or where intermediate layers of peat are thicker than 200mm either as a single layer, or the sum of the thicknesses of individual layers, throughout the length of the stone column
Highly sensitive soils	Ground liable to collapse or remoulding
Ground with fill	
Voided filled ground	Ground which includes, for example, old water tanks, pottery, glass bottles, concrete rubble or brick fill of unsuitable grading
Loose or non-engineered fill	Ground with any loose or non-engineered fill not previously subject to rising or fluctuating water levels or saturation
Filled ground which is still settling or expected to settle	Ground subject to settlement or settling: <ul style="list-style-type: none"> under its own weight or due to the effects of surcharging/upfilling where there is a high organic content where decay is continuing
Fill containing degradable material	Ground where organic material forms more than 15% of fill by volume

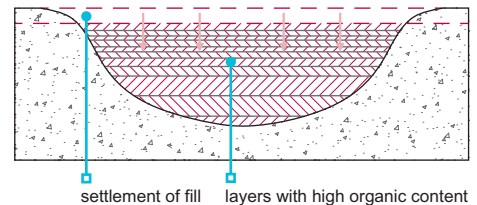

Highly contaminated ground

Ground which includes, for example toxic waste, or where inflammable, explosive or toxic gas generation may take place

Stone columns may act as vertical vents. Consideration will be given to proprietary systems which do not permit vertical venting such as vibro concrete plug technology

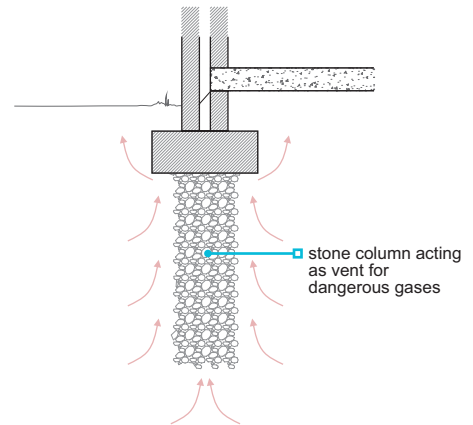

Detrimental factors

When specifying vibratory ground improvement techniques, the following factors should be considered:

- partial depth treatment of filled ground. The engineer should be satisfied with the anticipated performance of both the treated and untreated zones
- the specialist contractor should take responsibility for the treated zone and the depth of treatment
- alterations to the oversite level before or after treatment, or the disturbance of ground by excavations after treatment
- soils with a Modified Plasticity Index of 10% or greater; foundations should be designed to accommodate volume changes
- obstructions and variations in the density of fill and natural ground (hard spots) and the location of changes in the profile of the natural underlying ground, eg edges of pits or quarries, slopes, or manmade obstructions such as soakaways or drainage runs
- the minimum depth of soil treated, which should allow for the interaction of adjacent foundations
- stone columns that may form vertical drains, allowing the passage of water to a moisture-susceptible strata, or provide seepage paths for gases.

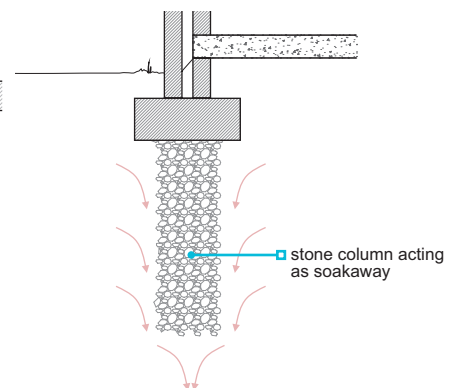
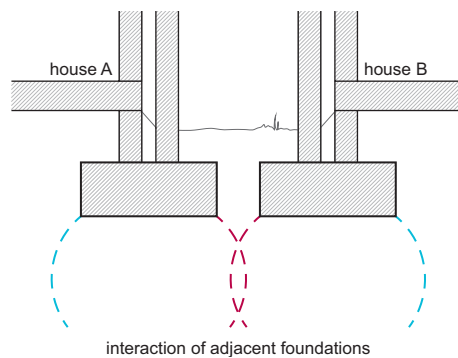
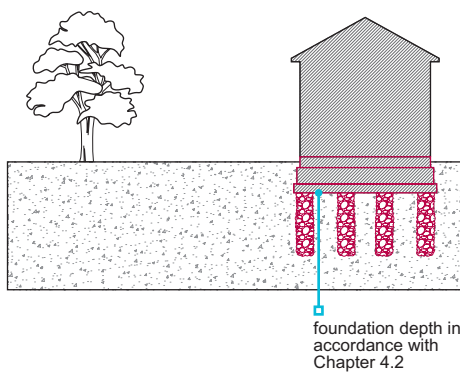

Ground water conditions

- long-term lowering of the water table causing settlement of existing adjacent buildings
- short-term rise in local water table due to large volumes of water used in wet process during construction causing settlement or heave of existing adjacent buildings.

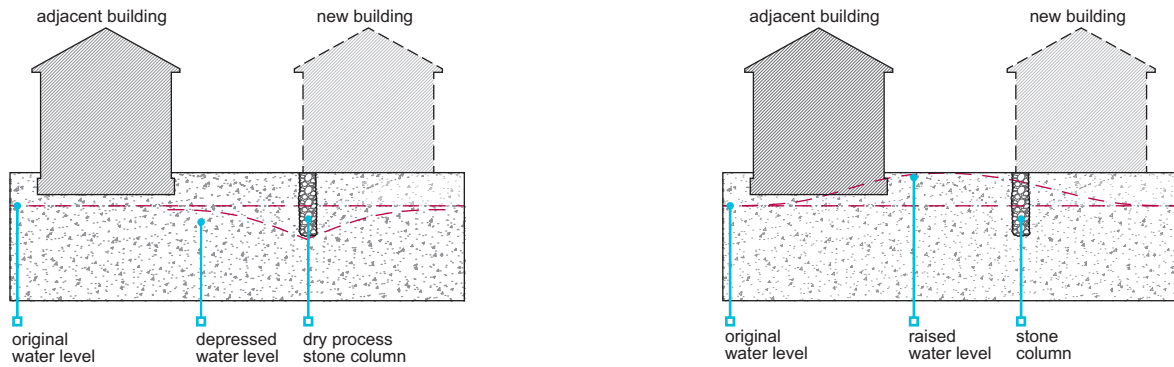

Surface water sewers should be used for rainwater disposal where possible, but where soakaways are necessary, these should be positioned so that their construction and operation is not detrimental to the treated ground.

The effect of any new or existing sustainable drainage systems (SuDS) should be taken into account when vibro improvement techniques are proposed.

4.5.6 Compatibility of the ground, design and treatment

Vibratory ground improvement techniques shall be compatible with the treated ground, site layout and the home design. Issues to be taken into account include:

- | | |
|--|---|
| <ul style="list-style-type: none"> a) limitations of the treated ground b) limitations of ground support c) suitable foundation types | <ul style="list-style-type: none"> d) use of suspended ground floors e) notice to NHBC. |
|--|---|

Limitations of the treated ground

The engineer should:

- avoid siting homes in locations where major changes in ground conditions can be expected
- consider limitations of the configuration of the homes including the vulnerability at junctions and of long blocks
- determine the loads to be imposed by the homes, and assess these against the results of the site investigation
- discuss the feasibility of proposals with the specialist contractor
- confirm the required load and settlement performance of the treated ground
- advise and discuss design criteria with NHBC at the design stage.

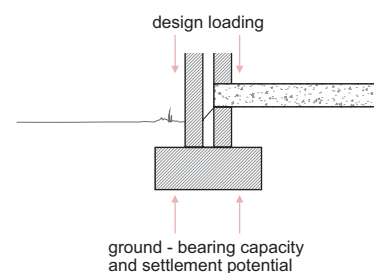
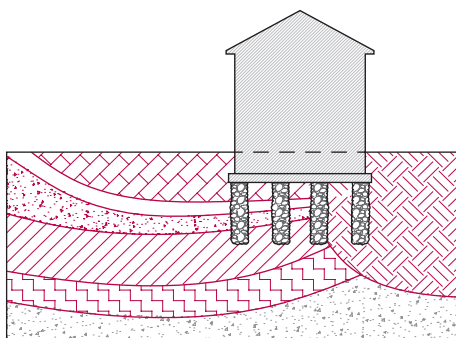

Limitations of ground support

The engineer should establish the likely limits of ground movement and account for this in the design, including:

- the position and spacing of movement joints
- the flexibility of masonry mortars
- masonry reinforcement.

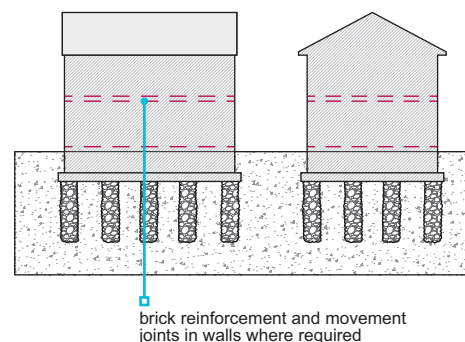

Suitable foundation types

The following criteria should be incorporated in the foundation design to ensure the compatibility and overall stability of the foundations and superstructure:

Only two types of foundations are suitable, both of which should comply with the minimum criteria for areas of reinforcement as defined in BS EN 1992-1-1. They are:

- reinforced concrete strip foundation
- reinforced concrete raft or semi-raft foundation positioned on a uniformly compacted bed of hardcore.

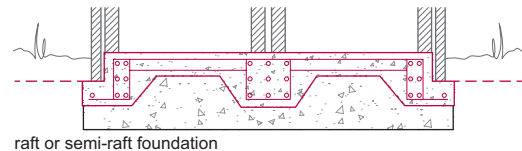
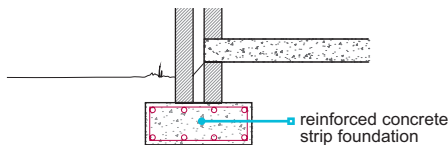

- for both types of foundation, top and bottom reinforcement should be provided
- the depth of foundations to be a minimum of 600mm below the surface of the treated ground, and founded on firm material of adequate bearing capacity
- where the treated ground is of a granular nature, a reinforced concrete strip foundation will normally be acceptable provided that the full depth of all fill material is treated
- if the treated ground is of a cohesive nature, a suitably designed raft, semi-raft or reinforced concrete strip foundation will normally be acceptable
- the reinforced concrete foundation should be designed to span between the centres of adjacent stone columns unless a more rigorous structural analysis is carried out to show that an alternative detail is acceptable
- if partial depth treatment of filled ground is proposed then a suitably designed reinforced concrete raft or semi-raft foundation should be used
- if during excavations for foundations in treated ground it is found that excessive depths of concrete are required, then precautions should be taken to ensure overall stability of the foundations, and the engineer should be satisfied that construction of the foundation will not be detrimental to the treated ground.

Use of suspended ground floors

Suspended ground floors should be provided for all homes where vibratory ground improvement has been conducted, unless the engineer can substantiate an alternative solution that is acceptable to NHBC.

Notice to NHBC

Where vibratory ground improvement is proposed, NHBC should be informed of:

- proposed development
- proposed start date of treatment.
- appointment of the specialist contractor

4.5.7 Acceptable methods

Vibratory ground improvement techniques shall only be conducted using methods that are appropriate to the ground conditions and acceptable to NHBC.

There are two main vibratory methods commonly used in the UK. These are known as the 'dry bottom feed' and 'dry top feed' methods. A third method, infrequently used in the UK and known as the 'wet bottom feed', is also acceptable to NHBC.

Dry bottom feed method

The dry bottom feed method is adopted in weaker soils or situations where there is a high water table and the bore hole is liable to collapse between vibrator insertions.

The vibrator penetrates by its mass, air flush and vibration. At design depth, the stone is introduced via a hopper into a pipe fixed to the side of a vibrator. The stone, generally of 40mm size, exits the pipe at the tip of the vibrator and discharges in to the bottom of the bore hole. The stone is then compacted into the surrounding soil by repeated withdrawal and insertion of the vibrator.

Dry top feed method

The dry top feed method is only used on cohesive soils where the bore hole can remain open. The vibrator penetrates the weak soil, or fill, by its mass, air flush and vibration to form a borehole.

Once refusal or design depth is reached, the vibrator is removed and stone fill introduced into the bore hole, the 'charge' is generally 500-800mm deep. The vibrator is re-inserted and 'packs' the stone into the surrounding strata. Successive charges of stone are added and compacted, bringing the column up to working level. The stone grading is generally 40-75mm.

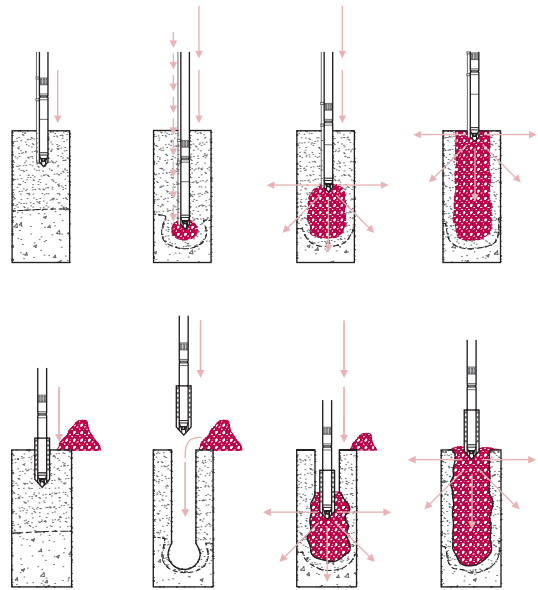

4.5.8 Materials for use as fill

Also see: BRE Special Digest 1 Part 1, BRE Digest 433 and BS EN 771

Stone fill for forming columns shall be compatible with the ground conditions, and be suitable for the vibratory ground improvement process.

Column fill should be a clean, hard, inert material. Limestone fill may not be acceptable in acidic ground conditions.

Suitable sources for fill material

All material used for fill should be suitable.

Where the material is of a stable and uniform type from one source, it may only be necessary to check its suitability once. Regular inspections and/or testing may be required where material is variable or from a number of sources.

Where material is obtained from stockpiles, the uniformity should be checked. Different forms of stockpiling can affect particle size and grading. The outside of a stockpile may be weathered and may not be the same as unweathered material. The use of recycled aggregate as fill should comply with BRE Digest 433 or other suitable guidance as agreed with NHBC.

Hazardous materials

The following materials require testing to ensure their suitability for use as fill to support structural foundations and slabs, or as backfill to associated trenches:

- acid wastes
- reactive materials
- materials that include sulfates, eg gypsum
- organic materials
- toxic materials
- materials that cause noxious fumes, rot, undue settlement or damage to surrounding materials.

Test requirements for fill material

Tests should be carried out by a suitably qualified person with a detailed knowledge of the:

- material to be tested
- proposed conditions of use.

The samples which are tested must be representative of the true nature of the material. It may be necessary to take a number of samples to find out the material characteristics of the fill.

Sulfate content should be expressed as a percentage SO₄ by weight on the basis of acid soluble testing, taking full account of the recommendations of BRE Special Digest 1 Part 1.

Fill material requiring NHBC acceptance

The following types of fill should not be used unless written agreement has been obtained from NHBC:

- colliery shale and any other residue from mineral extraction
- slags
- furnace ashes and other products of combustion
- material obtained from demolition
- on wet sites, or sites with a high water table, crushed or broken bricks which have no limit on their soluble salt content (as defined in BS EN 771)
- manufactured aggregates using materials from waste treatment plants.

Expansive fill materials

Fill containing expansive material is not acceptable for use as support to structural foundations and slabs, or as backfill to associated trenches.

4.5.9 Granular material

Granular material for raising site levels before treatment, or adding during deep compaction, shall be suitable for compaction and, unless appropriate precautions are taken, be free from hazardous materials.

The grading of material for adding during deep compaction should be within Zone A of Chart 1. Well graded, inert fill which passes a 100mm x 100mm screen in all directions and contains less than 10% fine material of silt or clay size will generally be acceptable for raising site levels.

Precautions, including testing where appropriate, should be taken where hazardous materials are present in fill.

4.5.10 Sitework

When using vibratory ground improvement techniques, the builder shall ensure that the engineer visits the site and provides competent supervision throughout the ground treatment process. Issues to be taken into account include:

- a) engineer checks
- b) location, depth and alignment of columns
- c) managing unforeseen circumstances.

Engineer checks

The engineer should provide competent site supervision throughout the ground treatment process and at critical stages, including:

- the inspection of setting out
- the installation of columns during the early stage of the work
- checking of materials
- where installation data differs from design assumptions
- where changes in treatment layout are required.

Some aspects of sitework may be the responsibility of the engineer or their representative, or of the specialist contractor, rather than of the builder.

Location, depth and alignment of columns

Supervision should ensure that:

- the minimum required depth of the stone columns is achieved and each one correctly located (the builder should provide sufficient profiles to enable locations to be checked)
- the stone columns are located either centrally under the foundations they are to support or are in the predetermined staggered arrangement, at a maximum of 2m centres and at the intersection of adjacent reinforced concrete strips
- missing stone columns are replaced
- stone columns which are misaligned by more than 150mm in any direction are replaced
- the location of all stone columns is checked by the engineer's representative prior to the specialist plant leaving the site.

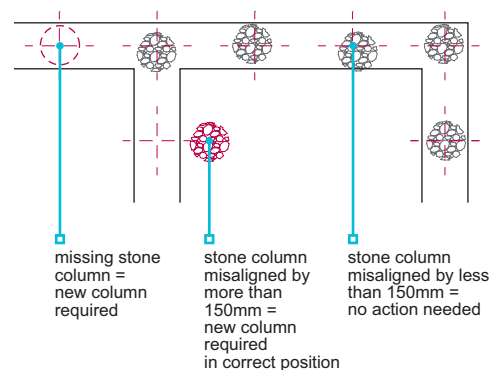
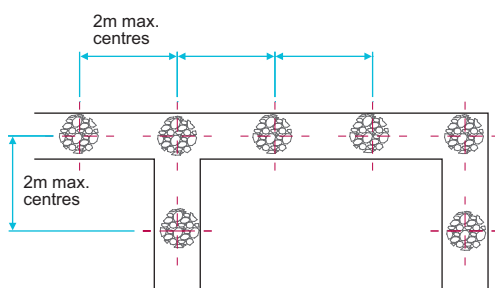

Managing unforeseen circumstances

Table 3: Actions for managing unforeseen circumstances

Circumstance	Action	In all cases
Unforeseen changes or trends which affect the site conditions	Recorded and reported to the engineer immediately	Where there is an effect on the final efficiency of the treatment, this should be fully considered by the engineer and the specialist contractor. The builder and NHBC are to be advised immediately regarding proposed remedial measures
Change in the anticipated depth of the compaction point in excess of 25%	Recorded and reported to the engineer and specialist contractor as soon as possible but no later than the end of the working day of occurrence	
Variation of over 50% in the quantity of backfill used in compaction points of the same length		

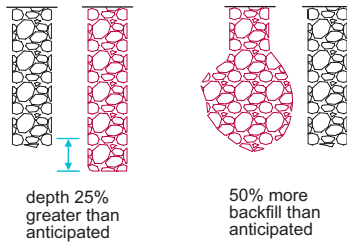

Allowance should be made for unforeseen obstructions that require either local removal and backfilling prior to treatment, realignment or additional columns, coupled with local amendment of foundation design.

4.5.11 Adjacent excavations

The builder shall ensure that foundations are not disturbed by adjacent excavations.

The engineer should consider the influence of drainage and other service trenches on the stability of the complete design.

The minimum clearance between excavations and foundations must not be less than the depth of excavation minus the depth of the structural foundation. Particular attention is needed for excavation below the water table.

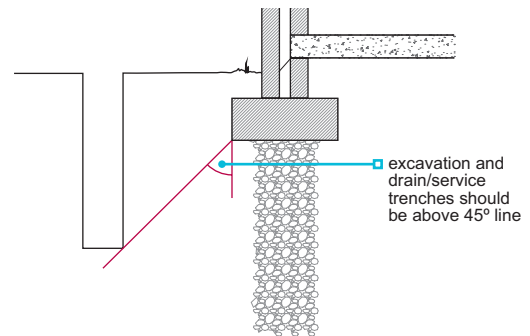

4.5.12 Verification of completed treatment

Also see: BR 391

The engineer shall require the specialist contractor to verify that the ground treatment is satisfactory, including:

- | | |
|--|-----------------------|
| a) suitable testing | c) recording of work. |
| b) written confirmation of completed treatment | |

Suitable testing

Tests should be carried out to establish the degree of ground improvement, the load-bearing characteristics and settlement potential.

The specialist contractor should:

- predict the results from his experience of work on the type of ground prior to the test taking place
- agree results and tolerance with the engineer prior to testing
- agree results and tolerance with the engineer with actual results.

Where the results are vastly different, a further investigation may be necessary.

Where a threefold improvement were predicted and only a twofold improvement achieved, this could indicate that the ground was different to that identified in the investigation, or that the treatment carried out differed from the specified treatment.

Tests on ground containing clay soils may need to be conducted several days after completion to allow excess pore pressures to dissipate. The engineer may choose any appropriate combination of the tests detailed in Table 4, with the agreement of NHBC.

Table 4: Test methods

Test	Comments
600mm diameter plate tests	<p>Plate tests will not determine the design but will allow for an assessment to be made of the workmanship on the stone columns.</p> <p>The tests should be carried out on stone columns or treated ground at a frequency of at least one test per day per rig</p>
Dummy footing test/mini zone test	<p>A mini zone test can be used as a limited substitute for zone tests. The test should be applied to at least two stone columns and the area of foundation which they support.</p> <p>The load may be applied through a rigid beam or stiffened plate using skips or other known loads, arranged to give a uniform distribution of the load</p> <p>Testing frequency should be at least one test per week per rig on normal sites. Where the site is of a geotechnically challenging nature such as lengthy columns of over 6m or treatment of variable fill or soft/weak natural soils, then additional test per week per rig will be required</p> <p>Mini zone tests should be continued for a sufficient time to allow creep behaviour to be quantified. Allowances for this time should be made in the overall project programme</p>
Zone test	<p>An isolated pad or strip footing is used to test up to eight stone columns and the intervening ground. Loadings which should simulate the dwelling loads are held for 24 hours at predetermined stages to examine creep behaviour</p>
In-situ test	<p>Where vibration will improve the ground itself, eg granular materials, then in-situ testing is appropriate.</p> <p>Improvement can be assessed when the in-situ test results are compared with the pretreatment investigation</p>
Trial pits	<p>Trial pits can be excavated around trial stone columns to prove that they are fully formed and to the required depth and diameter.</p> <p>This is a destructive test, and allowance should be made accordingly</p>

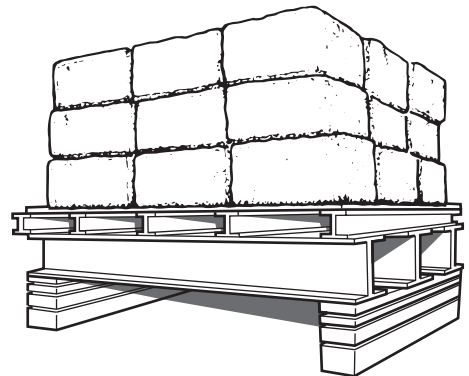
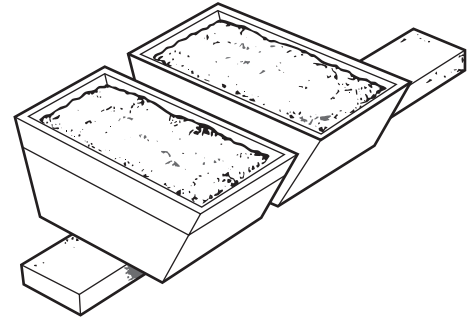

Written confirmation of completed treatment

On completion of the treatment, the engineer should:

- use the test results to verify that the treated ground has achieved the anticipated condition assumed in the design
- advise the builder and NHBC in writing of the verified effectiveness of treatment in relation to the design
- advise the builder of any special precautions which should be taken for the positioning of services both beneath the home and adjacent to it.

Recording of work

A comprehensive record of all works should be made available to NHBC, including:

- information concerning the treatment
- depth of fill
- volume of stone used
- on-site changes
- any other relevant information.



Chapter 4.6



Engineered fill

This chapter gives guidance on meeting the Technical Requirements and recommendations for using engineered fill to support residential developments, external works, and infrastructures.

4.6.1	Compliance	05
4.6.2	Provision of information	06
4.6.3	Hazardous sites and ground hazards	06
4.6.4	Desk study and ground investigation	06
4.6.5	Suitability of ground conditions	07
4.6.6	Materials for use as engineered fill	09
4.6.7	Design and specification of earthworks	11
4.6.8	Compatibility of fill with foundations, infrastructure and external works	15
4.6.9	Acceptable methods of earthworks filling	19
4.6.10	Site work	20
4.6.11	Adjacent excavations	22
4.6.12	Verification of engineered fill	22
4.6.13	Reporting	25

For figure reference tables in this chapter, please go to the end of the chapter



Introduction

On construction sites, filling or earthworks is often required for various purposes, such as preventing flooding, enhancing drainage, planning roads, or establishing a suitable ground profile. Engineered fill may also be used to replace existing made ground overlying competent strata at shallow to moderate depths to form the new development platform or be used below raft foundations on sites with shrinkable clays and trees in lieu of deep trench fill foundations.

This chapter details the information that NHBC requires to ensure that engineered fill is correctly placed to support low rise residential building structures, external works, and infrastructure while avoiding potential risks of excessive settlement or ground failure.

Scope

This chapter gives guidance for engineered fill to be placed for the support of the proposed development.

The interaction between engineered fill, underlying ground conditions and the development are important and site-specific. The primary objectives of this chapter are to ensure that:

- the ground investigation is appropriate to the proposed development, site conditions and nature of the filling
- geotechnical ground model(s) are developed taking into account the proposed development and underlying ground and groundwater conditions
- the engineered fill is placed to a suitable earthworks specification
- appropriate geotechnical laboratory acceptability testing and in situ, compliance testing is undertaken and documented, and verification is provided to NHBC
- engineered fills do not settle excessively or have the potential to cause excessive differential settlement between properties founded upon the fill and external areas
- engineered fill and the underlying ground supporting building foundations shall limit building settlements to less than 25mm and minimise angular distortion or tilt to 1:400
- the design and detailing of foundations, infrastructure and external works suit the placed fill and underlying ground conditions taking account of the overall ground model and any geohazards in the ground beneath or nearby.

The geotechnical and environmental suitability of historic fill or fill placed without full reporting should not be relied upon without appropriate site investigation, characterisation, compliance testing and assessment being undertaken like other made ground deposits would be assessed. This may need to include long-term monitoring or loading trials to determine performance.

Assessment of historic fill within land reclamation schemes and marginal sites is generally outside the scope of this chapter. For sites with uncertainty about the site's suitability for future residential development, please consult NHBC or consider using NHBC Land Quality Service for a bespoke consultation. You can find details about this service at:

- www.nhbc.co.uk/builders/products-and-services/consultancy/land-quality-service, or
- Email: lqs@nhbc.co.uk

The following are not considered in this chapter and will require more specific guidance from other sources:

- backfilling to retaining walls, buried features such as culverts, services or access chambers
- capping and sub-bases to roads, drives, parking, and hardstanding areas
- filling beneath adoptable highways
- soil stabilisation or soil mixing
- piling mats or other specific forms of working surface for construction activities
- fill containing hazardous substances or required to provide mitigation against the presence of contamination, or to be placed on contaminated sites
- use of reinforcing geogrids.

The builder is responsible for ensuring that any earthworks filling proposals do not breach planning requirements or waste and environmental regulations.

The following Figure 1 is to assist users in navigating through this chapter and it outlines how a proposed or existing earthworks fit into the applicability and use of this standard.

Figure 1: Fill assessment and chapter applicability process

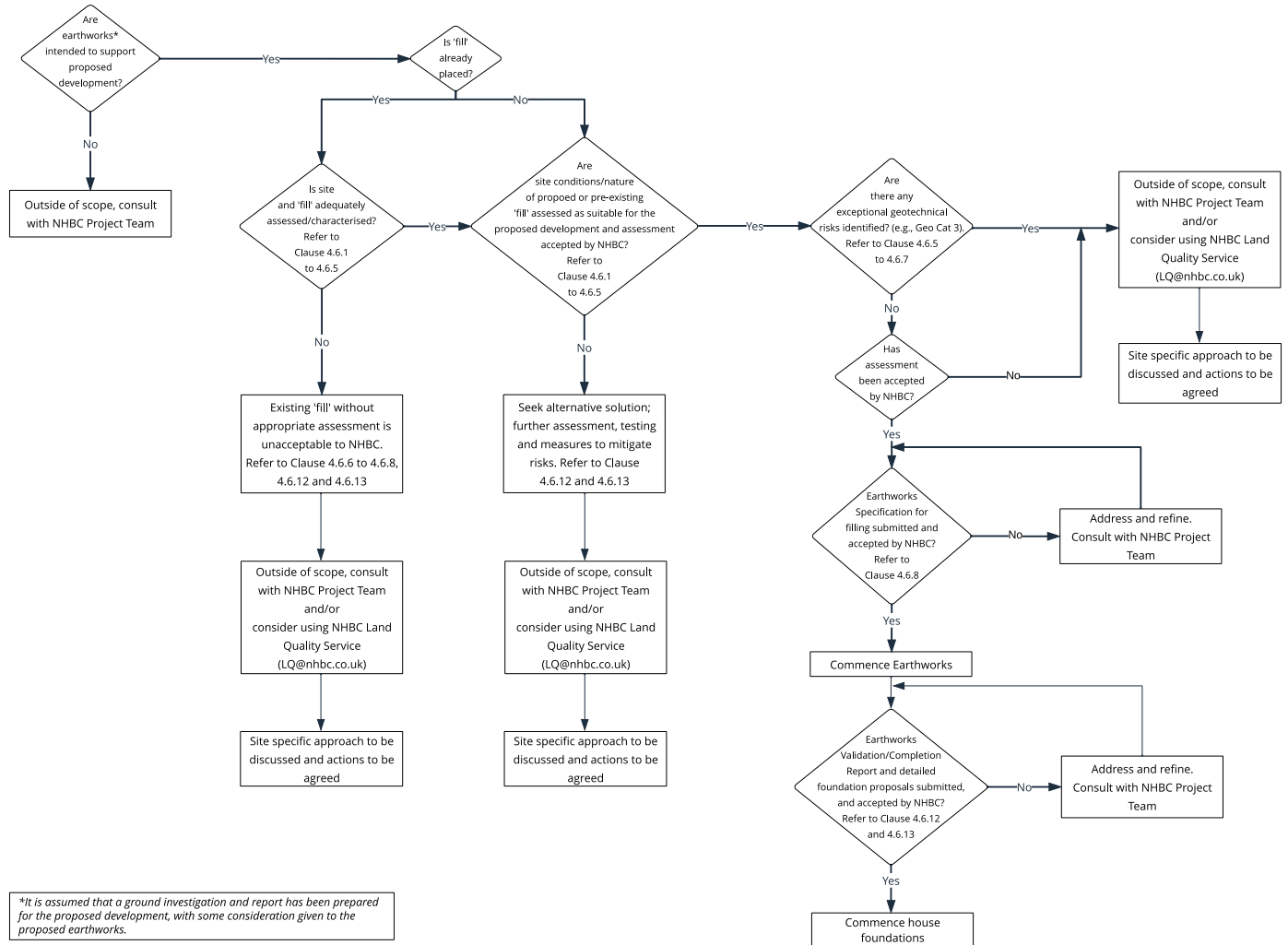

Definitions for this chapter

Acceptability testing	Geotechnical and chemical suitability testing of the source material(s) intended to be used as engineered fill
Beam grillage	A reinforced concrete foundation designed to support load-bearing walls or structure and to span a loss of support and reinforced with traditionally cut and bent rebars and closed-loop links
Buried batter	An inclined buried interface of natural soil and made ground or between made ground and engineered fill and potentially liable to cause differential settlement at the ground surface
Cohesive fill	Containing clay of natural origin, comprising greater than 15% fines passing a 0.063mm sieve. Suitable for use as engineered fill but requires greater moisture control than granular material. Behaves in a plastic manner and can be deformed and remoulded by hand. Suitability is typically dependent on moisture content. Only clays with a plasticity index of less than 40% are acceptable as fill, where they are required to support building foundations. This includes Class 2 (general fill) and Class 7 (selected fill) in accordance with the Specification for Highway works (Series 600 'Earthworks')
Compliance testing	Geotechnical suitability testing of the engineered fill as it is being placed in layers on site
Differential settlement	Settlement of one part of a building or structure relative to another. While the total settlement of a structure may interfere with functions such as service connections, it is the differential settlement that causes structural damage
Earthworks	Permanent change in ground profile and/or level, which may be due to the placement of fill (filling), the raising of the ground level (embankment) or the removal of material (cutting)
Earthworks specification	An earthworks specification describes the design requirements of proposed earthworks and contain how the earthworks should be undertaken and what acceptance criteria should be used to demonstrate its suitability
End-use	The nature of the proposed final development located over the fill, including the buildings and their foundations, external works and infrastructure features and associated activities in their normal use
Engineered fill (referred to as 'fill')	Fill that is selected, placed and compacted to an appropriate specification so that it will exhibit the required engineering behaviour to support structural loadings for buildings, external works (drives, paths, external walls) and infrastructure (roads, drains and services) without excessive settlement or risk of shear failure. Selected (structural) fill and General fill are examples of Engineered fill
Formation level	The prepared surface on which the engineered fill or the superstructure is built
General fill	Suitable for the support of access roads, drainage, driveways, and services buried within it or supported on it. Elements supported on general fill are usually less sensitive to differential ground movements than shallow foundations for residential buildings. Some degree of variability can be accepted in the completed fill, and fewer tests may be acceptable than for structural fill, however it will still require a suitable regime of compliance and verification testing
Geotechnical Design Report	A report that is used to develop a suitable and functional earthworks design for a proposed end use, which includes the full details on the interpretation of design data and justification for the design including relevant layout drawings. They are produced for Geo Category 2 and 3 projects where engineered fill is being used to support building foundations
Geotechnical Design Statement	A brief and abridged version of a Geotechnical Design Report for Geo Category 1 projects where engineered fill is not being used to support building foundations
Granular fill	Free draining material predominantly comprising sands and/or gravels Good for use as engineered fill Having less than 15% fines (less than 0.063mm sieve size) Behaves in a non-plastic manner This includes Class 1 (general fill) and Class 6 (selected fill) in accordance with the Specification for Highway works (Series 600 'Earthworks')
Ground improvement	Techniques used to stabilise or improve the strength of soils in situ. This includes dynamic compaction, rapid or high energy impact compaction, surcharging, and installation of vertical drains or vibro stone columns. These techniques may be applied to historic uncontrolled fill, loose native soils upon which engineered fills are to be placed or following placement of fill
Highwall	The steep edge of quarry or opencast workings. Where the quarry is backfilled, it usually forms a zone of contrasting material behaviour where ground movements could be excessive and affected by significant differential settlement
Historic fill	Comprises 'Made Ground' and is not suitable for supporting building foundations, access roads, drainage, driveways and buried services without full investigation and assessment which should be provided in a Ground Investigation Report
Immediate settlement	Settlement which takes place during the application of a load as a result of elastic deformation without change in the water content

Inundation settlement/ collapse compression	Occurs in poorly compacted Made Ground or fill placed dry of optimum moisture content and with high air voids. The failure mechanism is typically attributed to the subsequent rising of groundwater or surface water percolation, where the voids are filled with water and cause delamination. Burst pipes and leaking drains present a risk. It can occur in both cohesive and granular soils, with greater risk in cohesive soils
Landscape fill	Unsuitable to support shallow foundations for buildings, ground floor slabs for buildings, other critical elements sensitive to differential ground movements, or any external works such as pavements, services or garden walls. Loading may be limited to construction equipment. There may be no geotechnical testing requirements for landscape fill other than for workability reasons. Landscape fill may be specified for garden areas alongside earthwork slopes and bunds in some developments. They are sometimes referred to as Bulk fill
Made ground	Material that has been placed but to an unknown or unrecorded filling specification. Its geotechnical and geo-environmental properties need to be established by appropriate ground investigation and testing, for it to be reclassified and its suitability for reuse established
Material classification	Assignment of materials into groups and classes for earthwork purposes. The groups and classes are established by testing of the geotechnical properties of a material to determine its suitability for use as fill. The properties may include moisture content, grading, plasticity, compaction and recompacted CBR and shear strength etc. Testing continues during earthworks placement to ensure material properties remain consistent and within defined limits to achieve the required compaction or fill performance
Performance testing	Load-settlement testing of the completed engineered fill at its surface and ahead of building foundations
Primary settlement or consolidation	Occurs after immediate settlement of material on loading. It occurs as pore water pressures dissipate and usually comprises the most significant element of the total settlement of a cohesive fill. Completion of primary settlement is most easily identified by graphical analysis of settlement data showing a 'levelling off' behaviour as secondary settlement then commences
Raft foundation (Semi-rigid raft)	A foundation consisting of continuous slab elements and down stand beams designed in accordance with Chapter 4.4 to spread superstructure loads over the building footprint and provide a capacity to span a defined loss of support
Reinforced strip	A reinforced concrete foundation designed to support load-bearing walls or structure and to span a loss of support and typically reinforced with two layers of mesh reinforcement
Secondary settlement or consolidation	Occurs after Primary settlement (ie, creep) and may continue for many years including during the life of the development depending on the soil types
Selected and Structural fill	Suitable for the support of shallow foundations for buildings and other critical elements sensitive to differential ground movements or as backfill underneath ground-bearing slabs against earth-retaining structures. The completed fill is required to have a high degree of uniformity, high stiffness and low settlement potential and requires high degree of supervision and control and a high frequency of selection classification, compliance and verification testing
Self-weight settlement	Settlement induced in a fill due to its own mass. The magnitude of self-weight settlement is a function of both the stiffness of the fill, and its overall thickness. The contribution of self-weight settlement can be significant in cohesive soils
Soil Modification	Mechanical and/or chemical treatment of soils to create a suitable moisture content of an engineered fill to achieve the specified requirements of minimum relative compaction and maximum air voids. Processes include (non-exhaustively); destoning, formation of windrows with mechanical mixing or turning to promote air drying, addition of low-dosage (no greater than 2% by dry weight) binders such as lime and/or cement in order to moisture condition, lower plasticity and/or control silt fraction to promote optimal compactability
Soil Stabilisation	Mechanical and / or chemical treatment of soils to create substantial gain in strength to produce structural soil layers contributing significantly towards the performance or stability of earthworks. This would include (non-exhaustively) soil mixing with high dosage chemical admixtures or grouts, hydraulically bound materials and reinforced soils overlying weaker strata. It is currently outside the scope of this Chapter and not accepted for the support of foundations
Specification for earthworks	Are acceptable methods by which satisfactory compaction of fill materials can be achieved. The three main types of 'Specification for earthworks' used in the UK are Method, End Product and Performance
Total settlement	The combined magnitude of immediate, primary and secondary settlements

4.6.1 Compliance*Also see: Chapter 2.1*

Engineered fill shall comply with the Technical Requirements and provide adequate support for the proposed end-use. A suitably qualified and experienced Engineer shall be responsible for the design, specification, supervision and validation reporting to be submitted to NHBC for assessment.

Engineered fill placed to a suitable earthworks specification that complies with the guidance in this chapter will generally be acceptable to NHBC. Reference shall also be made to Chapter 4.1 'Land quality - managing ground conditions', for both geotechnical and contamination risks.

This chapter gives guidance for a wide range of circumstances where engineered fill is required. It is not the intention to describe all combinations of site conditions, end-uses, fill material types and filling techniques. Where conditions fall outside those described and detailed within this chapter, it is recommended that early engagement with NHBC should be undertaken prior to preparation of the earthworks specification.

The earthworks specification should be produced by a suitably qualified and experienced person acceptable to NHBC. Where engineered fill is to support building foundations, the earthworks specification should be produced by a suitably qualified Engineer - refer to Technical Requirement R5 for detail on requirements.

The earthworks specification should be supported by a Geotechnical Design Report, where engineered fill is being used to support building foundations. A Geotechnical Design Statement is acceptable where engineered fill is not being used to support building foundations.

British Standards, codes of practice and authoritative documents relevant to Engineered fill, Earthworks and Structures formed upon engineered fill are detailed in Table 1.

Table 1: British Standards, relevant codes of practice and authoritative documents

Relevant standard	Additional guidance
BS EN 1997-1	Geotechnical design. General rules
BS EN 1997-2	Geotechnical design. Ground investigation and testing
BS 6031:2009	Code of Practice for Earthworks
BS EN 16907	Earthworks. All parts
BS EN ISO 14688	Geotechnical investigation and testing – Identification and classification of soil. Parts 1 & 2
BS EN ISO 14689	Geotechnical investigation and testing – Identification, description and classification of rock
BS EN ISO 17892	Geotechnical investigation and testing – Laboratory testing of soil
BS EN ISO 22476	Geotechnical investigation and testing – Field testing. All parts
BS 1377	Methods of test for soils for civil engineering purposes. All parts
BS 10175	Investigation of potentially contaminated sites – Code of practice
BRE FB 75	Building on fill: geotechnical aspects
BRE IP 5/97	Building on fill: collapse compression on inundation
BRE 427	Low-rise buildings on fill. All parts
BRE 433	Recycled Aggregates
BRE SD1	Concrete in aggressive ground
ICE	Earthworks: a guide (by Nowak & Gilbert)
National Highways	Specification for highway works: Series 600 - Earthworks
National Highways	CD 622 – Managing geotechnical risk
CIRIA C574	Engineering in chalk
CIRIA C504	Engineering in glacial tills
CIRIA C570	Engineering in Mercia mudstone

4.6.2 Provision of information

Earthworks design and specifications shall be produced in a clearly understandable format, including all relevant information and shall be distributed to all appropriate parties.

The earthworks specification and accompanying information including relevant drawings should be submitted to NHBC at least eight weeks prior to the commencement of filling or associated works. The earthworks specification should also be issued to site supervisors, the earthworks contractor and relevant specialist subcontractors. See clause 4.6.7 for details of what should be included within an Earthworks Specification.

An earthworks method statement, from the Earthworks Contractor or equivalent, should be produced and issued to all relevant personnel, which describes how the requirements of the specification are to be delivered, the plant to be used and arrangements for supervision and reporting.

In addition, the following supporting information should also be provided to NHBC:

- desk study and ground investigation report
- geotechnical design report or geotechnical design statement (depending on which is relevant)
- materials classification (acceptability) assessment
- earthworks verification report.

This list is not exhaustive and additional content may be required depending on site specific circumstances.

4.6.3 Hazardous sites and ground hazards

Also see: Chapters 2.1, 4.1 and 4.2

Placement of engineered fill on hazardous sites shall be reported to NHBC before work on site commences and shall be specified to take account of any ground hazards.

Hazardous sites, as defined in the NHBC Rules, should be reported to NHBC in writing at least eight weeks before earthworks begin.

Details of ground hazards to be taken into consideration are given in Chapter 4.1 'Land quality - managing ground conditions' and Chapter 4.2 'Building near trees'.

4.6.4 Desk study and ground investigation

Also see: Chapters 2.1, 4.1 and 4.2

A desk study and ground investigation shall be undertaken, and the findings used to inform the design of the filling and earthworks specification.

A desk study and sufficient ground investigations should have been undertaken to characterise the site and identify all the features and potential geotechnical and environmental ground hazards relevant to the earthworks, including classification of the fill material itself.

The ground investigation should take account of the findings of the desk study and relevant standards listed in clause 4.6.1. Further guidance is given within Chapter 4.1 'Land quality - managing ground conditions'.

The desk study and ground investigation should determine the following items listed in Table 2, as a minimum:

Table 2: Typical items to be covered by desk study and ground investigation

Item to be determined	Guidance
Site history and past usage (eg, agricultural, residential, commercial or industrial)	To aid in determining a ground model for the site and potential areas of concern
Known areas of made ground	As shown on BGS Geo-index, other geodata services, historical site investigations and their reports
The nature of the underlying geology	To determine the potential for soft, loose soils, instability, voids, or highly compressible soils and to allow an assessment of pre or post treatment of the existing ground
The proximity of any existing buildings, roads or services	To assess whether these could be affected by ground movement caused by filling
The strength/density, compressibility and stability of soils beneath the proposed fill and for the potential re-use for fill earthworks	To enable the level of risk to be determined including settlement of the underlying soils and whether unsuitable material needs to be removed or if any form of pre-treatment is required. To assess the acceptability of site derived fills
The nature (presence and extent) of any groundwater and surface watercourses	To assess whether groundwater (or surface water) may affect the existing made ground/natural soils or newly placed fill – for example by causing inundation settlement or washout of ‘fines’
The geotechnical properties of soils including sulphate content and pH	To determine the suitability of soils for use as engineered fill and for the design of buried concrete
The presence of any slopes, embankments, cuttings, quarry highwalls, buried batters or earth faces	To assess the potential negative effect of earthworks on existing ground stability and the potential effect of features on the performance of earthworks and foundations bearing upon the placed fill
The presence of any buried services, culverts, tunnels or other buried structures	To assess the effect of structural loading from earthworks and associated earthworks machinery and whether protection or mitigation measures are required
The presence of contaminated substances or materials suspected to be contaminated	To assess whether cut earthworks and placement of filling may cause, or increase, the release of contaminants such as leachate, hazardous ground gases, etc refer to Chapter 4.1 ‘Land quality - managing ground conditions’
Geotechnical Risks	An initial geotechnical risk register to ensure that all known or anticipated natural or man-made geohazards are identified and can be investigated and considered within evolving stages of investigation, designs and earthworks execution

Other items to consider in addition to Table 2, but not repeated here, are listed in Table 1 of Chapter 4.5 ‘Vibratory ground improvement techniques’ and in Chapter 4.2 ‘Building near trees’.

Where a ground investigation has been undertaken without considering the proposed earthworks, it may be necessary to carry out further supplementary investigation, sampling, testing, and/or monitoring to inform the earthworks design and earthworks specification.

4.6.5 Suitability of ground conditions

Also see: Chapters 2.1, 4.1 and 4.5

The ground to be filled over shall be suitably stable and appropriate for the proposed earthworks and end-use. Issues to be taken into account include:

- 1) unsuitable ground conditions
- 2) obstructions
- 3) compressible soils
- 4) unstable ground
- 5) groundwater conditions.

The geotechnical design should be prepared by a suitably qualified and experienced Engineer who should assess the ground and be satisfied that it is suitable for engineered fill. Prior to earthworks commencing, the formation level should be inspected and tested in accordance with the earthworks specification.

Engineered fill may be placed on natural ground or made ground – both need to have been appropriately investigated to assess their suitability to provide long-term support to the engineered fill and proposed end-use. Where engineered fill is to be placed on made ground, the made ground will be considered as a residual geotechnical risk for the purposes of geotechnical design.

It may be acceptable to partially excavate existing ground and recompact it in place in order to provide a stiffened layer with improved bearing capacity, settlement characteristics and reduced permeability (as required). Settlement of both the engineered fill layer and the ground beneath should be assessed.

4.6.5.1 Unsuitable ground conditions

Prior to the execution of earthworks filling, unsuitable materials should be removed from the formation level including:

- topsoil, tree roots, highly organic matters, or other degradable materials
- frozen soils
- excessively wet or soft soils such as silty soils or clays with an undrained shear strength of less than 40kPa, where not treated to adjust their soil properties
- contaminated soils, and soils containing slag or combustible materials.

Unsuitable materials may be treated, in some circumstances, to adjust and improve the soil properties. Further assessment would be required to determine their suitability after treatment and prior to any subsequent placement as engineered fill.

4.6.5.2 Obstructions

Obstructions including oversized materials or relic foundations that may impede future works in the ground or adversely affect earthworks filling or drainage of the ground should be removed.

It may be impractical to remove some obstructions beneath engineered fill such as former piles etc. These should be adequately surveyed, and their locations accurately recorded. Any retained relic structure or obstructions should be a minimum of 2m beneath the underside of proposed building foundations.

4.6.5.3 Compressible soils

Where compressible soils are present such as soft clays, disturbed ground or peat, the effects of earthworks should be assessed including the magnitude and duration of induced settlements.

Where significant settlements of the underlying soils are predicted, it may be necessary to undertake compaction works, removal or ground improvement works, such as the installation of vertical drainage, or surcharging prior to filling of earthworks.

The effects of 'drying out' of compressible soils such as peat beneath engineered fill, should be assessed where earthworks may reduce water infiltration, or the development may cause lowering of groundwater levels.

4.6.5.4 Unstable ground

Voids that might collapse or cause excessive settlement (ie, dissolution features, mine workings and entries, sewers and drains) should be adequately investigated and suitably infilled or grouted prior to the commencement of any earthworks filling or building foundations.

Unstable natural deposits or materials susceptible to solifluction (materials that have undergone progressive, gravitation and downslope movement) should be adequately investigated and addressed by the geotechnical design.

4.6.5.5 Groundwater conditions

The following conditions may adversely affect the long-term performance of engineered fill, if not properly considered and allowed for within the design and specification:

- lowering of the water table to facilitate filling may cause settlement of existing adjacent buildings
- rising or recovery of groundwater levels after filling may cause inundation settlement of fill or wash-out of 'fines' and settlement
- falling groundwater could cause settlement of soft strata, including peat
- lack of surface water management (ie, non-provision of adequate capping and drainage) following earthworks to ensure no subsequent deterioration over time.

4.6.6 Materials for use as engineered fill

Also see: BRE SD 1-Part 1, BRE Digest 433, BS EN 771 and ICE's Earthworks: a guide.

Engineered fill materials shall be suitable for the site conditions, proposed end-use and techniques of placement and compaction. Issues to be taken into account include:

- 1) suitable sources of engineered fill materials
- 2) treatment of fill materials.

The earthworks specification should indicate the materials to be used for filling including their geotechnical classification and range of properties that should be subject to monitoring and testing. Material classification should be clearly stated eg Class 1C Coarse Granular General fill or a Class 6N Well Graded Selected Granular fill in accordance with Specification for Highway Works.

Materials that do not fully comply with the earthworks specification must not be used as engineered fill.

4.6.6.1 Suitable sources for engineered fill materials

Engineered fill material may be site-won or imported from appropriate suppliers or donor sites. Where differing engineered fill types are placed in subsequent layers or distinct zones, it is important to ensure compatibility – for example, to ensure that fines are not washed out of one material into a more coarsely graded material, geotextile separators may be required.

Where material is obtained from stockpiles, the homogeneity should be confirmed. Different forms of stockpiling can affect particle size and grading. The outside of a stockpile may be weathered and may not be the same as the unweathered material within. The use of recycled aggregate as fill should comply with BRE Digest 433 or other suitable guidance as agreed with NHBC.

Details of considerations regarding the acceptability of materials for re-use as engineered fill are provided in Table 3. Tests undertaken to confirm acceptability should be carried out by a UKAS and/or MCERT Accredited laboratory (or other specialist laboratories) in accordance with the earthworks specification, appropriate standards and industry guidance, with a detailed knowledge of the materials to be tested and proposed end use. The samples which are tested must be representative of the true nature of the material.

Table 3: Acceptability of materials for re-use as engineered fill

Material Description	Examples of Material	Details on Acceptability for re-use as fill
Suitable sources for fill materials	<ul style="list-style-type: none"> Natural sands and gravels Clays with a plasticity index of less than 40% and undrained shear strength in excess of 40kPa Chalk (structured chalk of grades C5 - A1 only) Crushed rock Crushed concrete, brick or stone 	Typically, the material would be acceptable to NHBC for engineered fill, provided that they comply with appropriate classification criteria. For material that is solely crushed brick, further assessment of strength will be required to ensure its durability
Hazardous materials	<ul style="list-style-type: none"> Reactive materials Materials that include sulphides or sulphates, eg gypsum Organic materials Materials that cause noxious fumes, rot, undue settlement, or damage to surrounding materials 	Appropriate testing required to demonstrate their suitability
Fill material requiring NHBC acceptance	<ul style="list-style-type: none"> Unburnt colliery spoil or shale (Carbonaceous Mudstone) with excessive coal or pyrite content Colliery shale (ie, burnt shale, or red blaze) Steel slags Furnace ashes and other products of combustion Material obtained from demolition without screening, crushing and processing Soils with a silt content greater than 20% Highly variable materials On wet sites, or sites with a high-water table, crushed or broken bricks which have no limit on their soluble salt content (as defined in BS EN 771) 	Not to be used as engineered fill unless a written agreement has been obtained from NHBC
Unsuitable fill materials	<ul style="list-style-type: none"> Soils containing topsoil or significant organic matter (such as leaves or wood) greater than 6% by volume Degradable, reactive, or non-durable materials Expansive materials, (ie, steel slag and gypsum containing materials) where testing has not determined their risk Materials capable of releasing contaminants or hazardous gases Combustible materials (ie, materials with a high calorific value greater than 7MJ/kg) placed within the top 1m of the finished development platform Materials containing significant amounts of plaster, plastic or rubber up to 2% by weight Materials containing harmful substances, which pose a risk to human health and the environment Materials with high sulphate content where Total Potential Sulphate (TPS) is in excess of 0.25% Structureless chalk (with grades Dm and Dc) Materials that are not generally used as engineered fill on residential sites 	Fill containing these constituents are NOT acceptable for use

4.6.6.2 Treatment of fill materials

The following techniques may be used to modify the moisture content of materials to render them suitable for use as engineered fill:

- placement in windrows or layers with mechanical turning as required for drying purposes
- the addition of lime and/or cement, typically up to 2% by weight to reduce the moisture content to nearer the optimum moisture content (OMC) for maximum dry density
- the addition of water by spraying or similar to increase the moisture content to nearer the OMC for maximum dry density.

The following techniques are not acceptable to NHBC for the treatment of materials for use as engineered fill:

- stabilisation to improve strength by the addition of over 2% lime or the addition of any cement or other hydraulic materials
- the addition of chemical binders or grouts.

4.6.7 Design and specification of earthworks*Also see: BS EN 1997-1, BS EN 16907-1, BS 6031*

A suitably qualified engineer shall be responsible for the design and specification of earthworks taking into account future development and type of building foundations. Engineered fill shall be placed in accordance with a suitable Earthworks Specification. Items to be taken into account include:

- 1) geotechnical design
- 2) earthworks specification
- 3) types of specification.

Engineered fill should be placed to a suitable earthworks specification – the scope, details and requirements of the specification should be appropriate to the site, the nature of the fill, the techniques of placement and the end-use of the site.

4.6.7.1 Geotechnical design

On engineered fill sites, an element of geotechnical design will be required by NHBC. The complexity of the design and its supporting earthworks specification should reflect the scope of works and the associated risk. Geotechnical design is covered in BS EN 1997, with earthworks specifically covered by the requirements set out in BS 6031 (Code of practice for earthworks) and BS EN 16907 (Earthworks).

It is recognised that on certain residential developments, the level of earthworks required can be minimal, with a low to negligible risk associated with the project. Where the scope of the earthworks is defined as Geotechnical Category 1 (Geo Cat 1), based on the Table below, a Geotechnical Design Statement (GDS) shall be prepared and submitted to NHBC.

Most earthworks are classified as Geotechnical Category 2 (Geo Cat 2) in accordance with BS EN 1997-1 and are required to be designed by an appropriately qualified and experienced person. Where the scope of the earthworks is defined as Geo Cat 2 or 3, a Geotechnical Design Report (GDR) shall be prepared and submitted to NHBC.

The content lists of a GDS or GDR may be prepared using guidance from DMRB CD 622 as a guide. Both the GDS and GDR should be prepared by a suitably qualified Engineer.

The following Table 4 – ‘Geotechnical design categories’ should be used to attribute a geotechnical category to projects, and the subsequent requirements for Geotechnical Design Statement (GDS) or Report (GDR).

Table 4: Geotechnical design categories**Assessment of the site and proposals**

Geohazards – legacy of mining/quarrying, un-engineered fill, low strength/bearing capacity, slope stability, etc

Preparatory works – removal of remnant foundations, obstructions, settlement monitoring, mining treatment, etc

Requirement for ground improvement – preloading, surcharging, dynamic compaction, etc

Category	Scale and extent of earthworks and end-use	Required information
<p>Geo Cat 1 SIMPLE</p>	<p>Considered to have negligible geotechnical risk and may be designed adopting a qualifiable approach. The Geotechnical Design Statement and earthworks specification should clearly define the scope of works covered by the Geo Cat 1 design and can be presented on drawings, accompanied by appropriate risk assessment</p> <p>Typical sites would include:</p> <ul style="list-style-type: none"> ● greenfield sites ● no geotechnical hazards ● suitable existing ground conditions, no or minimal preparatory works and ground improvement measures ● placement of engineered fill limited to proposed infrastructure, external works and earthworks slopes no steeper than 1V:5H ● use of General fill only 	<p>A Geotechnical Design Statement (GDS)</p> <p>Summary based on good local experience and ground conditions that are well known and uncomplicated</p>
<p>Geo Cat 2 CONVENTIONAL</p>	<p>Considered to have no exceptional geotechnical risk associated with them, either during or post construction. The records of the quantifiable design shall be presented in the Geotechnical Design Report which should be accompanied by the earthworks specification</p> <p>Typical sites would include:</p> <ul style="list-style-type: none"> ● brownfield sites ● some or many geotechnical hazards to be removed or suitably mitigated. ● some or many preparatory works to be undertaken, the requirement for one or more ground improvement measures ● placement of engineered fill limited to proposed infrastructure, external works and earthworks slopes steeper than 1V:5H, and ● placement of engineered fill supporting building foundations and settlement sensitive elements ● use of Selected and General fill 	<p>A Geotechnical Design Report (GDR)</p> <p>Based on the current BS EN 1997-1</p>
<p>Geo Cat 3 COMPLEX</p>	<p>Considered to have exceptional geotechnical risk with unstable ground conditions. Geo Cat 3 designs require an independent third-party check and are not covered by the requirements of this Chapter</p> <p>Typical characteristics include:</p> <ul style="list-style-type: none"> ● mostly brownfield sites ● many geotechnical hazards to be removed or suitability mitigated ● requiring a wide range of preparatory works to be undertaken ● exceptionally difficult ground conditions with ongoing instability, ground movements or requiring investigation and special measures ● placement of engineered fill supporting very large or unusual structures/buildings 	<p>A Geotechnical Design Report (GDR)</p> <p>Typically, outside the scope of this standard</p> <p>Consultation with the NHBC and/or the Land Quality Service</p> <p>lqs@nhbc.co.uk</p>

4.6.7.2 Earthworks Specification

The earthworks specification should be prepared once the earthworks design has been undertaken and the properties of the proposed fill material have been established. It should clearly describe the design requirements to be satisfied, ie, detail how the engineered fill is to be placed and what criteria will apply to prove its compliance and include the information detailed below. An earthworks specification should be practicable and capable of both measurement and enforcement and should be capable of being monitored by an effective form of quality assurance procedure.

Typical Earthworks Specification should include the following:

1. Description of scope and aims of the earthworks including reference and brief summaries of supporting documents:
 - a. Desk study and Ground Investigation Report
 - b. Geotechnical Design Report or Geotechnical Design Statement
 - c. Materials Classification (Acceptability) Assessment
2. The intended end-use of the engineered fill should be defined
3. Details of any site preparation works required prior to earthworks filling and the treatment of exposed surfaces to prevent deterioration
4. Types of materials permitted for use together with material properties. This should include arrangements to prevent the deterioration of cohesive materials
5. Classification testing may include particle size distribution, plasticity (Atterberg limits), compaction tests, or moisture content tests should be undertaken to confirm that the fill materials remain within the earthworks specification
6. The types and frequency of classification tests should be site and material specific and should be confirmed in the specification. Acceptable test methods and frequencies of classification tests are given in Tables 9 and 10 of BS 6031: 2009
7. Requirements for the placement, spreading and compaction of earthwork materials, including compliance criteria
8. Requirements for the disposal of unsuitable material
9. Testing proposals for the verification of compliance criteria and performance requirements to be met for End Product and Performance specifications, including load-settlement testing
10. Arrangements for supervision
11. Proposed as-built records to reflect the completed works
12. Construction drawings showing the proposed extent of the filling works (including thickness)
13. All other site-specific requirements and relevant construction drawings showing retained features, constraints, etc
14. The form and proposed content of an Earthworks Validation Report

4.6.7.3 Types of specification

Three types of standard Specifications for Earthworks are acceptable to NHBC, and these are:

- method
- end product and
- performance.

Method specification defines how compaction should be conducted in terms of the types of compaction plant, method of operation, number of passes of the plant and the final thickness of the compacted layer.

The End Product specification defines the degree of compaction necessary, and if appropriate stiffness requirement, for the given material by reference to criteria linked to either serviceability or ultimate limit states. The level of compaction required is normally expressed in terms of selected geotechnical properties eg, percentage of maximum dry density or prescribed minimum stiffness and is supported by on-site earthworks testing. Where an end product specification is used, the requirements normally define overall targets to be achieved without detailing the methods to be used to achieve the targets.

Performance specifications require the works to be defined relative to long-term project requirements, which are commonly set at a relatively high level. For example, the criteria may be defined based on the long-term fitness for use of a building that is to be formed upon the completed earthwork. NHBC requires a performance specification to be used in combination with an end product specification.

NHBC specification requirements for use on residential development are summarised in the following Tables 5 & 6.

Table 5: Types of Specification for earthworks acceptable to NHBC

Specification	Specification requirements
Method	<ul style="list-style-type: none"> • The thickness of fill layers to be compacted • Type of compaction plant • Number of passes required • Compaction requirements (typically 90% maximum dry density and <10% air voids)
End Product	<ul style="list-style-type: none"> • The geotechnical properties to be achieved following placement of engineered fill - typically dry density, moisture content and air voids • The criteria for acceptable compliance and compaction requirements (see Table 6) • Proposals in the event of non-compliance
Performance	<ul style="list-style-type: none"> • Defined by relative long-term projects requirements eg, engineered fill and the underlying ground supporting building foundations shall limit building settlements to less than 25mm and minimise angular distortion or tilt to 1:400 for 60-year design life • NHBC requires a Performance Specification to be used in combination with an End Product Specification • The behaviour the completed engineered fill is required to achieve under testing – usually limits of settlement under specified load and/or over time • Details of the performance testing to be undertaken, including testing frequency • Proposals in the event of non-compliance during placement and of performance testing

Table 6 provides the minimum level of compaction required throughout the placement of all engineered fill for both the support of building foundations and external and infrastructure works.

Table 6: End product acceptance criteria

End Use	Acceptance criteria
Building Foundations	>95% MDD* and <5% air voids (4.5kg or vibrating rammer) >98% MDD* and <5% air voids (2.5kg rammer)
External/Infrastructure	>95% MDD and <5% air voids where fill > 5m thick (2.5kg / 4.5kg rammer) >90% MDD and <10% air voids where fill <5m thick (2.5kg / 4.5kg rammer)

*MDD = Maximum Dry Density

It may be appropriate for a project technical specification to incorporate different forms of earthworks specification for different types of fill material, eg method compaction for general fills and end product compaction for coarse granular fills.

The earthworks technical specification shall include relevant conditions to be satisfied during construction to ensure the following are met:

- materials are chemically suitable for the project and the surrounding environment
- materials should be durable, and not prone to deterioration or non-biodegradable
- earthworks should provide a stable finished surface that will limit post-construction settlement or movement within the engineered fill
- the earthworks should provide a surface of sufficient stiffness and/or shear strength for the intended use.

Once agreed with NHBC, the earthworks specification should not be amended on site without prior agreement with the NHBC.

The earthworks specification should be based on industry guidance such as the Specification for Highway Works, BS EN 16907 'Earthworks', ICE Publishing – Earthworks: A Guide '2nd Edition', or on trials/previous experience, that is acceptable to NHBC.

The earthworks specification should outline if placing, testing and verification of earthworks fill is to be completed on the whole site, or be undertaken and presented in a phased approach to facilitate the build programme.

Table 7 shows the types of earthworks specification that are acceptable to NHBC for different types of engineered fill and subsequent end-use, considering the starting ground (formation) level has been assessed as suitably stable and appropriate for the proposed earthworks and end-use (as per clause 4.6.5).

Table 7: Matrix for determining appropriate types of earthworks specification

End-use	Support of foundations	Support of external works	
Depth of fill	N/A ¹	<5m	>5m
Granular and Cohesive fill types (including mixed fills)	End Product plus Performance (Reinforced Strip and Beam Grillage)	Method	End Product
	End Product (Semi-Raft)		

Notes

1 Acceptable minimum depth of engineered fill beneath building foundations = 600mm.

Figure 2 illustrates the guidelines for the use of differing earthwork specification for different end-use, located in close proximity.

Figure 2: Compaction and differing end use

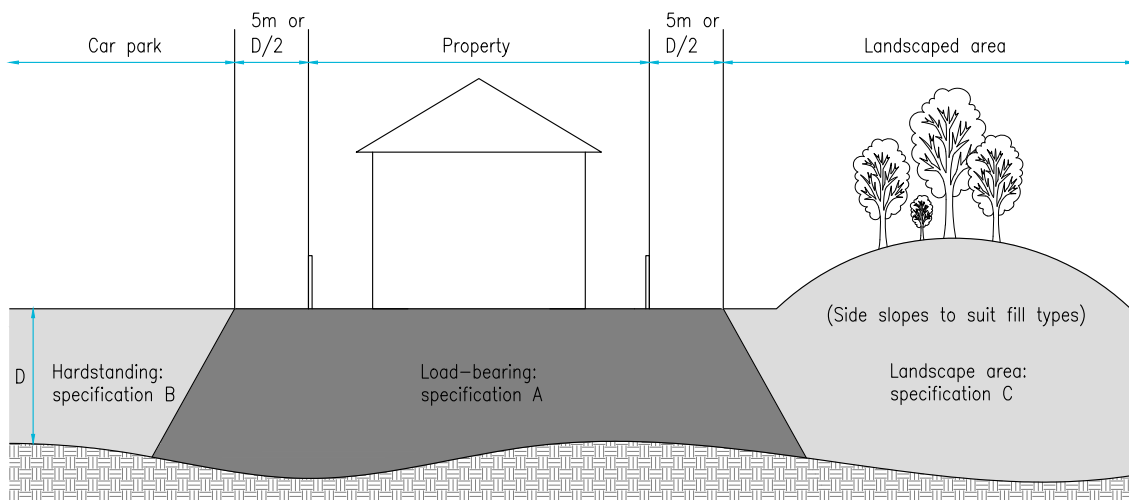

D - Denoted average engineering fill thickness at the location concerned

NOTES:

1. Specifications A & B to be to Table 7
2. Specifications C may be Method or End Product or no defined compaction regime

4.6.8 Compatibility of fill with foundations, infrastructure and external works

Placed engineered fill shall support foundations, infrastructure and external works as required without excessive settlement. Items to be taken into account include:

- 1) building and foundation types
- 2) engineered fill performance and Foundation Options
- 3) building settlements and relative movements
- 4) external works and infrastructure.

This section provides guidance on building foundations that will generally be acceptable to NHBC. Where more rigorous structural or geotechnical analysis is carried out alternative solutions may be acceptable, but these must be agreed with NHBC in advance of development.

4.6.8.1 Building and foundation types

Engineered fill covered within this chapter should be capable of supporting foundation loads from buildings of three storeys or equivalent weight.

Where compliance testing of engineered fill demonstrates a high level of consistency and quality in combination with a high level of supervision and control, a suitably structurally designed reinforced strip foundation may be acceptable. This can be so in conjunction with ground hazards and risks associated with excessive settlements being suitably addressed. A suitably structurally designed beam grillage will also be acceptable.

Where engineered fill has been placed to a suitable earthworks specification with a satisfactory verification testing, a semi-rigid raft foundation in accordance with Chapter 4.4 will be acceptable to support buildings.

Reference should also be made to the requirements of Chapters 4.2 'Building near trees' and Chapter 4.3 'Strip and trench fill foundations' as appropriate. Cohesive fill material should be taken as having a similar volume change potential (and requirement for minimum foundation depths) as natural clays of the same plasticity index.

4.6.8.2 Engineered fill performance and Foundation Options

Residential developments founded on engineered fill are more sensitive than other structures or infrastructure founded on the same material and requires foundation solutions that will mitigate the potential for both aesthetic and structural damage over the design life of the building. Any foundation solution adopted should be sufficiently robust to accommodate the predicted future settlements and prevent damage to building superstructures. To provide the required stiffness, rigidity and robustness against unwanted movements, all foundations on engineered fills should be reinforced. Unreinforced strip footing would not be acceptable to NHBC under any circumstances.

Table 8 indicates the minimum requirements necessary for a shallow foundation to be used on engineered fill and considers different foundation types that may be used based on the achieved compaction of the engineered fill only. The table should only be used where no other residual geotechnical risks are present and assumes that the engineered fill is placed on competent natural ground.

The foundation specified should consider the holistic geotechnical design (eg, bearing capacity and settlement) and also allow for any retained geotechnical risks outside or below the engineered fill. Table 8 should not be used to justify a less robust foundation where unresolved geotechnical risks remain.

Where the requirements of Table 8 have not been significantly achieved, for example poor execution or poor site supervision or inadequate testing or reporting, or where the verification of the earthworks falls outside the minimum requirements given below, an alternative foundation solution outside this chapter will need to be considered – ie, solutions from Chapter 4.4 'Raft, pile, pier and beam foundations' or Chapter 4.5 'Vibratory ground improvement techniques'. Where piles are considered, the potential for negative skin friction on the piles due to creep settlement of the placed engineered fill and/or the consolidation of any underlying soils should be assessed.

Table 8: Engineered fill Performance and Acceptable Foundation Options

Proposed outcome	Reinforced strip	Beam grillage	Semi-raft
Minimum relative compaction (% maximum dry density) ¹	>95	Majority of results >95 However, results show some variability and non-compliances (see Figure 7) No results <90	Majority of results >95 However, results show some variability and non-compliances (see Figure 7) No results <90
Maximum air voids (%)	<5	Majority of results <5 However, results show some variability and non-compliances (see Figure 7) No results >10	Majority of results <5 However, results show some variability and non-compliances (see Figure 7) No results >10
Supervision	A very high degree of independent supervision Full time independent resident geotechnical engineer dedicated to inspection, supervision and testing of the fill	A high degree of independent supervision Full-time inspection of the filling by an independent resident geotechnical engineer	Good/normal supervision Part-time inspection of the filling by an independent geotechnical engineer
Contractor	Experienced/specialist earthworks contractor	Experienced earthworks contractor	Suitably experienced groundworker or earthworks contractor

Engineered Fill	Fill generally of consistent depth and properties throughout Fill behaviour should have been proven by precedent or trials	Fill generally of consistent or steadily varying depth Little variation in fill properties	Effects of variations in fill depth and properties should be assessed with predicted settlements established
Foundation performance testing	Zone load tests and/or mini zone load tests and Plate load tests across fill depth and at surface ²	Mini zone load tests and Plate load tests across fill depth and at surface ²	Plate load tests across fill depth and at surface ²
Verification	Earthworks Verification Report produced by a third-party organisation	Earthworks Verification Report produced by an experienced earthworks contractor	Earthworks Verification Report produced by an experienced earthworks contractor/groundworker
Foundation design	Design by a suitably qualified Engineer to relevant British Standards Designed for moment to span 2m as simply supported and 1.0m as a cantilever ³	Design by a suitably qualified Engineer to relevant British Standards Designed to span 3m as simply supported and 1.5m as a cantilever	Design by a suitably qualified Engineer to Chapter 4.4 'Raft, pile, pier and beam foundations'

Notes

- 1 Modified Proctor hammer (4.5kg).
- 2 Minimum 600mm diameter.
- 3 Foundations to be typically reinforced with mesh reinforcement at top & bottom.

In circumstances where there is a potential increased or significant geotechnical residual risk of long-term creep settlements, for example as a result of the type or thickness of placed engineered fill or underlying thickness of made ground beneath the engineered fill, a stiff reinforced concrete raft or stiff beam grillage foundation may be required.

4.6.8.3 Building settlement and relative movements

The total settlement between any part of the building foundation and the surrounding ground or external area, should not normally exceed 25mm over the 60-year design life.

Where engineered fill or the underlying ground, is undergoing steady uniform settlement a total foundation settlement of over 25mm may be acceptable, provided the differential settlement is compliant with the guidance below and the foundation solution is sufficiently robust.

The tilt or distortion (differential settlement) of any part of the foundation should not exceed 1 in 400. The potential differential settlement of any foundation should be assessed where:

- the depth of fill significantly varies,
- there is a tapered layer of compressible material,
- a quarry highwall or buried batter is present.

Where predicted total or differential settlements of any part of the building foundation exceed the above criteria further assessment will be required to determine suitable alternative foundation solutions. The presence of highwalls, in particular will require rigorous assessment including their location, geometry, and observed load-settlement behaviour of the engineered fill following remediation, if they are to be considered by NHBC to be suitable to build residential development upon.

The effects of differential settlement between external areas and buildings should be assessed in particular where these are piled or supported on vibro columns. Additional means of support or measures to mitigate ground movement may be required where excessive settlements could be realised, ie, the use of flexible drainage and/or surcharging.

The following Figures 3 and 4 show examples of engineered fill over rolling landscape and over buried features where part removal of the feature was necessary to mitigate excessive tilts.

Figure 3: Engineered fill over gentle rolling landscape

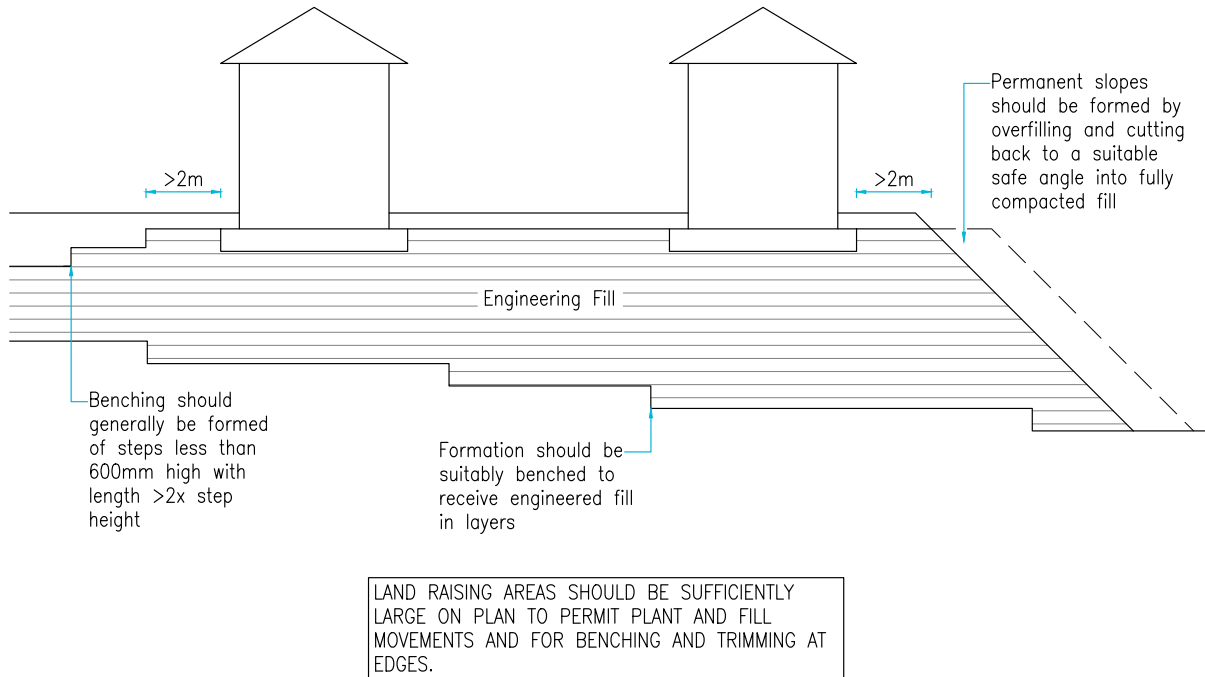
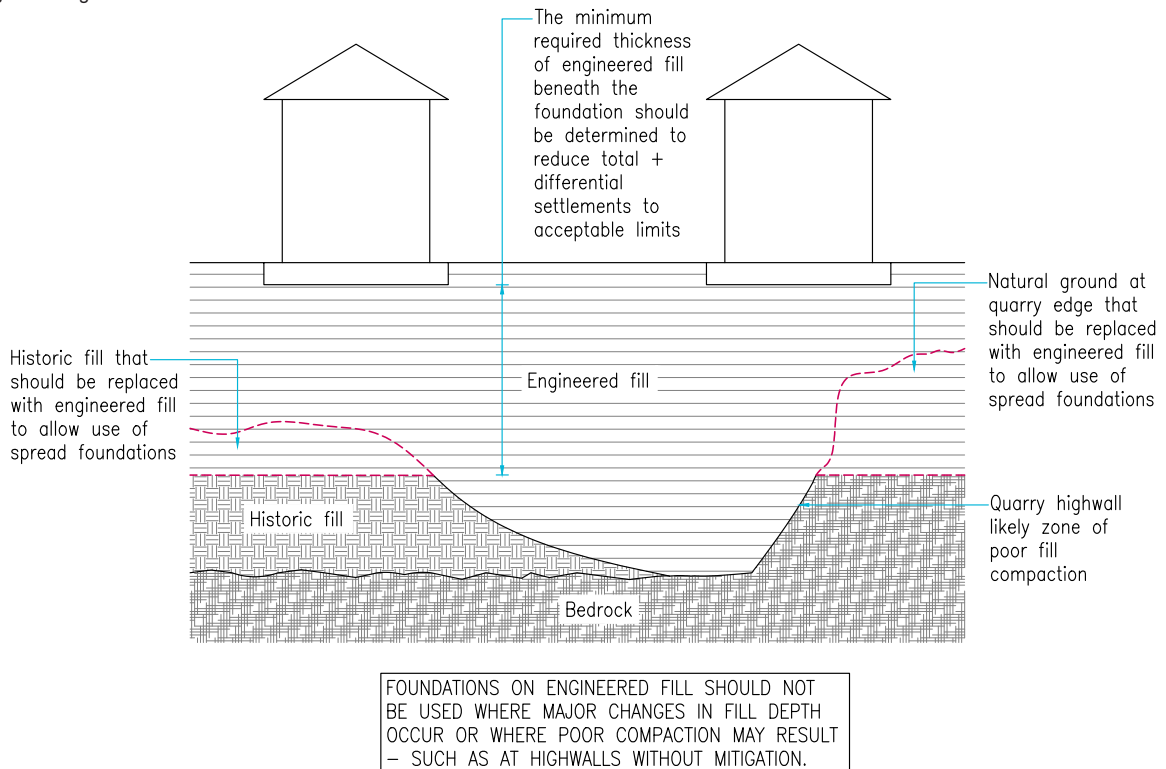

Figure 4: Engineered fill over buried features



4.6.8.4 External works and infrastructure

It will generally be acceptable to support low height retaining walls and boundary walls on mass concrete or reinforced foundations placed on engineered fill. Walls should be provided with joints and/or reinforcement as considered appropriate to provide flexibility and structural integrity while accommodating ground movements particularly at locations where depths of engineered fill and settlements may vary. Geotechnical and structural designs are required where retaining walls are in excess of 0.6m in height.

Wall foundations, hardstandings and roads should be designed according to appropriate guidance and achieved geotechnical properties of the engineered fill.

Where external works and infrastructure pass from engineered fill to the natural ground or where the depth of engineered fill varies significantly, the potential for differential ground movements should be assessed and catered for. Additional measures should be provided as necessary eg, the use of geogrid or futureproofing drains by potentially laying to steeper falls and the use of flexible jointing.

For areas not within the influence of building foundations (ie, hardstanding, gardens, infrastructure or external works areas), a maximum total long term settlement of over 25mm would generally be acceptable subject to serviceability design limits. See Figure 2 above for an approximate delineation of these areas.

4.6.9 Acceptable methods of earthworks filling

Also see: SHW Series 600

Earthworks filling shall only be undertaken using methods acceptable to NHBC that are appropriate to the materials, site conditions and end-use. Items to be taken into account include:

- | | |
|----------------------------|--------------------------------|
| 1) conventional compaction | 3) preloading and surcharging. |
| 2) non-standard compaction | |

4.6.9.1 Conventional compaction

Placement and compaction of engineered fill should be undertaken in layers of controlled depth using appropriate plant. Acceptable methods are considered to be those based on the recommendations from The Specification for Highways Works (SHW) Table 6/4.

The type and size of the compaction plant should be based on the volume or depth of engineered fill to be placed, the classification of the fill to be compacted, and the specification requirements.

4.6.9.2 Non-standard compaction

This aspect covers all methods of compaction, which are not covered by SHW Table 6/4. Details of non-standard plant and techniques should be submitted to NHBC in writing at least eight weeks before site works begin. Non-standard techniques include, but are not limited to:

- rapid impact compaction (RIC), utilising a rammer
- high energy impact compaction (HEIC), utilising polygon or triangular rollers
- dynamic compaction, utilising heavy drop weights dropped from a crane.

NHBC will require evidence of the effectiveness of non-standard plant or techniques, or demonstration of the suitability of proposals for the site conditions by trials as appropriate, particularly for large or complex projects. Site trials including testing requirements should be designed and agreed with NHBC prior to commencement. Trials must accurately reflect the proposed filling techniques and achieve specified performance requirements and may require post treatment investigation and load testing.

4.6.9.3 Preloading / Surcharging

Placement of a surcharge may be an acceptable form of ground improvement but should not be used in place of the compaction techniques described previously. The design of surcharge including the magnitude and duration of the surcharge requires careful analysis.

The effectiveness of surcharging should be demonstrated by monitoring or by trials. The requirements for monitoring and supervision are outlined in BS EN 1997-1 and BS 6031 and should be presented in the GDR. The surcharge load should be maintained until the achievement of the design requirements has been demonstrated. Refer to BRE FB 75 for further guidance.

4.6.10 Site work

Also see: BS EN 16907-5 and BS 6031

The developer or builder shall ensure suitable supervision, sampling and testing are performed throughout the entire duration of the earthworks. Filling shall be undertaken by a competent Contractor using materials, personnel and plant appropriate for the nature of the site conditions and proposed end-use. Issues to be taken into account include:

- | | |
|----------------------------|--|
| 1) supervision and records | 4) material acceptability and compliance testing |
| 2) site preparation | 5) actions in respect of non-compliant fill |
| 3) material handling | 6) protection of fill. |

4.6.10.1 Supervision and records

The developer or builder must arrange for a suitable site supervision and recording of the works appropriate to the scale and complexity of the project and proposed end-use of the fill. The recording of the site works should be in accordance with the requirements of the earthworks specification. Guidance on the level of information that is required to demonstrate the quality of the works is available in BS EN 16907-5.

4.6.10.2 Site Preparation

The site should be prepared in accordance with the earthworks specification with all vegetation, topsoil, fly tipped, and unsuitable materials removed prior to filling. If suitable, topsoil should be placed in segregated stockpiles for reuse onsite or elsewhere. Where excess topsoil is present, this may be removed under the Material Management Plan (MMP).

The formation should be prepared by proof rolling with any hard or soft spots identified and remediated in accordance with the earthworks specification. Temporary drainage may be required to keep the formation dry.

Relic structures, for example old foundations and hard standings, should be removed from below engineered fill areas in their entirety wherever practicable. As a minimum, relic structures and obstructions should be removed to at least 2m below any proposed foundation. All structures or uncharacteristic elements (including boulders) greater than 1.0m in diameter/length left in the ground at formation should be surveyed and their positions recorded.

When recording the depth of engineered fill, it is essential (eg, for use in subsequent pile designs) that the formation should be surveyed prior to filling on a maximum 10m grid arrangement.

Site constraints and features to be preserved (for example monitoring wells, public rights of way, watercourses and trees to be retained) must be clearly identified and all necessary protection and safety measures must be implemented. Alternatively, their removal or any reinstatement measures should be specified as appropriate.

Where the sub formation is sloped, the sides should be stepped at a maximum height of 600mm to allow the engineered fill to be benched into the existing natural ground or achieved otherwise as stated in the earthworks specification. Figure 5 shows what may be required on a sloping site close to the development platform where filling is required.

Figure 5: Benching of sloping natural ground

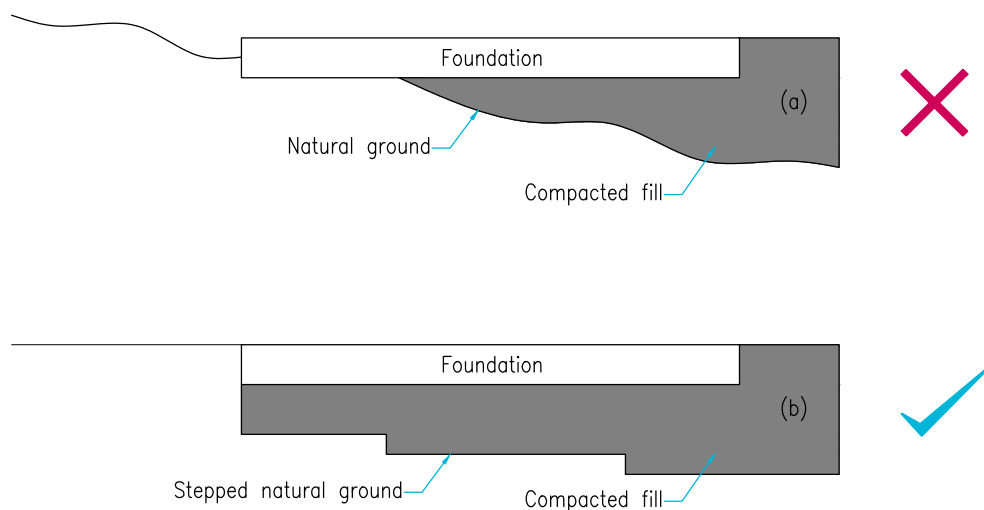

NOTES:

- a. Proposed development platform straddling over natural and fill areas
- b. Preferred development platform with well prepared and stepped fill area beneath

4.6.10.3 Material handling

In addition to the required classification testing, site-derived materials should be routinely inspected during excavation to ensure consistency and correlation with the expected ground model.

Imported fill should be subject to periodic inspection from the donor site prior to arrival at the site and regular inspections once delivered. Classification testing should be undertaken as required prior to placement, particularly where the material is not provided with independent certification and where visual assessment suggests the material classification varies.

Engineered filling should not be undertaken in inclement weather conditions. Where the engineered fill is cohesive, placement and filling should be paused during extended periods of rain. For sensitive materials like chalk, care should be taken not to over-compact the fill further than specified.

Engineered fill must be placed and compacted in accordance with the specification, within a defined moisture content range close to the optimum moisture content as derived from relevant laboratory testing.

For cohesive fill materials, the moisture content is critical in achieving the desired dry density. Engineered fill that is compacted too dry of the optimum moisture content (OMC) risks being vulnerable to collapse settlement or heave when wetted. Engineered fill that is compacted too wet of optimum moisture content risks being too weak to provide adequate support without excessive settlement.

Engineered fill should proceed in near horizontal layers (to assist in shedding surface waters) with each layer fully compacted before commencing the following layer. The maximum layer thickness for method compaction should be based on the type of fill material, the classification of the fill material, placement and the method and plant employed.

For end product compaction, an uncompacted layer thickness of up to 250mm subject to site-specific requirements would be acceptable. The maximum particle size should not be greater than 1/3 of the compacted layer thickness or 75mm, whichever is lower.

Differing engineered fill material types should not be placed in the same layer, they should be placed at predetermined layers and defined depths appropriate to their properties and the proposed end-use.

Filling activities should be planned and carried out so that:

- vibrations do not disturb existing or nearby properties, excavations, slopes, buildings, services or infrastructure
- filling and earthwork machinery does not overload retaining features, slopes, buried services or infrastructure
- ground movement including around the area of filling does not harm adjacent buildings, services or infrastructure
- temporary slopes (filled or in cut) are safe and stable
- under compaction and over-compaction are avoided
- the rate of placement of fill does not result in excess pore water pressure leading to failure of the underlying ground.

4.6.10.4 Material acceptability and compliance testing

Classification and compliance testing should be in accordance with BS EN 16907-5 and BS 6031:2009. Laboratory testing should be undertaken by a UKAS and/or MCERTS accredited specialist. All testing should be to a current British or EN Standards eg, BS 1377, using appropriately calibrated equipment. Testing should be undertaken throughout the duration of the fill placement in accordance with the guidance in clause 4.6.12.

4.6.10.5 Actions in respect of non-compliant fill

Where testing indicates compacted engineered fill does not fully comply with the requirements of the earthworks specification, appropriate action should be agreed as soon as possible with NHBC. Possible actions include:

- drying of engineered fill material prior to further placement of subsequent layers
- excavation and replacement of the engineered fill represented by the test failure
- additional compaction (if the failure is shallow or at the surface) and retesting
- if the non-compliance is regarded as a marginal outlier and represents part of a normal spread of test data, it may potentially be deemed acceptable without further action. It should be recorded in the Earthworks Verification Report
- undertaking appropriate performance testing.

The possible extent of non-compliant engineered fill needs to be carefully assessed and whether the non-compliance may indicate unsuitable placement and compaction techniques or poor site conditions or excessively variable fill or unsuitable material. Where there is a divergence from the earthworks specification the Designer should be notified, and advice sought.

Remedial action needs to be carefully undertaken and recorded avoiding disturbance to previously placed compliant engineered fill.

4.6.10.6 Protection of fill

Compacted engineered fill should be protected from deterioration due to trafficking, poor weather and pooling surface water. Suitable measures include laying the surface to falls to assist drainage or use of a durable granular sealing layer or sacrificial layer.

4.6.11 Adjacent excavations

The builder shall ensure that foundations within engineered fill are not disturbed by adjacent excavations.

The Engineer should consider the influence of drainage and other service trenches on the stability of the complete works.

Excavations in engineered fill may require additional trench support, even at relatively shallow depths. Health and Safety Executives' (HSE) advice with respect to the design and management of below ground temporary works, including those for excavations, man-entry, etc must be adhered to.

The Earthworks Verification Report should identify and duly reference any constraints to excavation because of buried features, contamination or unusual ground conditions.

The minimum horizontal clearance between excavations and foundations must not be less than the depth of excavation minus the depth of the structural foundation. Particular attention is needed for excavation below the water table, where encountered.

Figure 6: Placement of excavation adjacent foundation on engineered fill

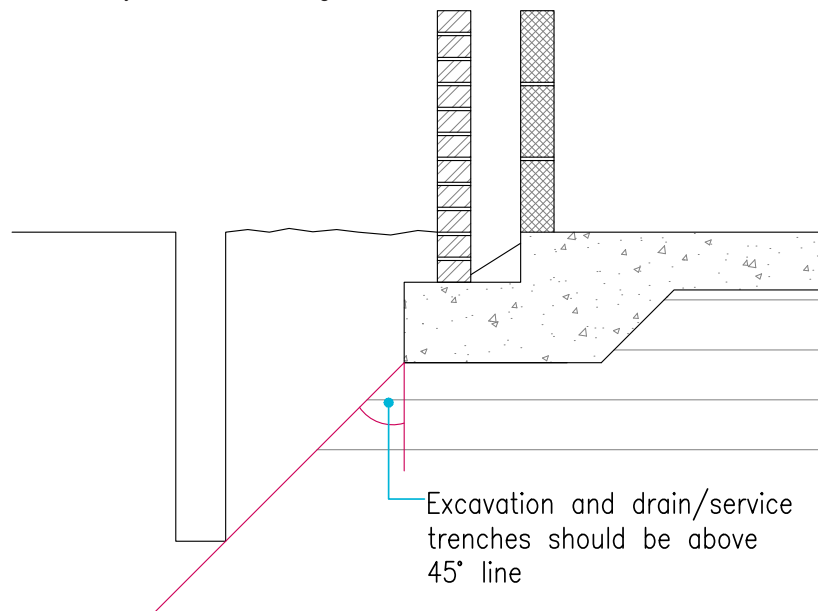

4.6.12 Verification of engineered fill

Also see: BS EN 16907-5, BS 6031 and BRE 427

Verification testing of engineered fill shall be undertaken to confirm compliance with the earthworks specification and its fitness for purpose. Items to be taken into account include:

- 1) fill classification
- 2) end product testing
- 3) performance testing
- 4) settlement measurement
- 5) testing frequency.

Validation and verification of the filling should be in accordance with BS EN 16907-5 and BS 6031:2009. Laboratory testing should be undertaken by a UKAS and/or MCERTS accredited specialist. All testing should be to a current British or EN Standards eg, BS 1377, using appropriately calibrated equipment.

Testing should be undertaken on a combination of random and targeted locations through the full depth of the fill to ensure consistency across the site. Higher risk locations (for example deeper engineered fill, heavier/larger buildings or where engineered fill was placed in less suitable conditions) should have a robust data set to confirm that fill has achieved the required geotechnical compliance criteria.

The testing frequency should be set out in advance of the works in the Earthworks specification.

4.6.12.1 Fill classification

Classification testing including particle size distribution (grading), plasticity (Atterberg limits), 4.5kg rammer compaction tests or moisture content tests, should be undertaken throughout the earthworks to confirm that the engineered fill materials remain within the acceptability limits set out in the earthworks specification.

The type and frequency of classification tests should be site and material specific and should be confirmed in the earthworks specification. Acceptable test methods and frequencies of classification tests are given in Tables 9 and 10 of BS 6031:2009.

4.6.12.2 End product testing

Fill compaction is most commonly established by comparing the in-situ dry densities and moisture contents with the laboratory determined maximum dry density and optimum moisture content. NHBC will normally accept engineered fill verified to achieve the criteria given in Table 6. There may be variation to these requirements where differing material types or foundations are adopted, or where there is a risk of future inundation of the fill.

The in-situ densities of engineered fill may be measured using sand replacement tests (SRTs), nuclear density tests (NDTs) or electromagnetic density gauges (EDGs). Where NDTs or EDGs are used, the results should be regularly calibrated against SRTs. Where there is variation in the fill materials, the use of NDT results to assess compaction may not be reliable.

4.6.12.3 Performance testing

Table 9 indicates suitable tests to assess earthworks performance. The type and frequency of testing should be appropriate for specific site conditions and the proposed end-use. It is recommended that a minimum of three tests of each type are undertaken, so that a trend can be observed from the results with the exception of preloading by surcharge.

Table 9: Types of Performance Testing

Test /Parameter	Description	Application
Preloading by surcharge	An area usually greater than 50m ² is raised above the proposed development level with soils or fill to model the proposed development loadings	For large sites or areas of deep fill (over 5m deep) or where highly compressible soils exist at depth, usually in conjunction with other performance tests such as zone tests, plate tests or probing
Zone load	A rigid base (usually made up of concrete) with areas related to the width of the proposed foundations, typically between 4-10m ² Suited to modelling the loading and depth of influence of a building on raft foundation The test duration to be sufficient to identify the magnitude and timescale for completion of primary settlement, the clear trend of any secondary settlement (creep) and to confirm that load-settlement behaviour is in accordance with calculated predictions	For large sites or areas of deep fill usually in conjunction with other performance tests such as plate tests or probing undertaken to identify suitable locations for the zone test Care must be exercised during the zone tests, pads/bases are susceptible to ground vibrations/movement resulting from machinery/plant
Mini zone load/pad	Smaller than a zone test – with an area less than 4m ² and designed to model a typical (or heaviest) part of a spread (beam grillage or reinforced strip) foundation The test duration to be sufficient to identify the magnitude and timescale for completion of primary settlement, the clear trend of any creep and to confirm that load-settlement behaviour is in accordance with calculated predictions	Usually in conjunction with other performance tests such as plate tests or probing to identify suitable locations for the zone test Care must be exercised during the mini zone load tests, pads/bases are susceptible to ground vibrations/movement resulting from machinery/plant
Surface points settlement	A stable concrete or steel level monitoring point set at the surface or at shallow depth to determine the nature of any fill settlement without applied loading – usually over a prolonged period to model self-weight consolidation and creep settlement as required	Where self-weight consolidation or creep settlement may be significant – usually associated with deep cohesive fill
Settlement rods	Plates placed at the underside of engineered fill to measure settlement caused by the placement of fill	Usually in conjunction with other performance tests such as zone tests and mini zone load tests
Magnetic extensometers	Can be placed at varying depths within engineered fill or underlying made ground in deep fill sites to record settlement from targeted zones	Usually in conjunction with other performance tests such as zone tests and mini zone load tests

Plate test	Usually 600-900mm diameter plate and loaded incrementally to 1.5-3.0 times the highest proposed bearing pressure The peak load is held for up to 1 hour or until the rate of settlement does not exceed an agreed limit The use of dual cycle plate load tests can provide a significant improvement on the assessment and interpretation of the data. Wherever possible, dual cycle plate testing should be employed	Inexpensive but may not load the fill as deeply as a foundation, limited to approximately 1.5x the plate diameter Most suitable during fill placement
Probing	A range of techniques are available	Static cone testing can provide data on the surface to depth of soil, including soil stiffness and other important soil properties Shallow techniques (including hand-held) may be limited in data quality
Permeability	Infiltration testing in boreholes or trial pits at the depth of interest	Where low permeability is required to limit groundwater (or ground gas) movement
Inundation	Similar to permeability testing but with added settlement monitoring	To assess the susceptibility of fill to settlement when it becomes saturated (from surface water, service trenches or rising groundwater)
Hand vane	Undrained shear strength of cohesive fill. Quick and easy but of limited reliability and accuracy	For cohesive fill Any gravel within the soil matrix that comes into contact with the cruciform pattern of the 4no. vanes can significantly alter the results. It should only be used in conjunction with other tests as a confirmatory tool

Proposals for testing should be agreed in advance of the works and should be set out in the earthworks specification with supporting test plan(s). Test locations should be selected to allow a satisfactory spatial and lateral spread of results.

The pass criteria for the performance tests should be detailed in the earthworks specification and Geotechnical Design Report/ Geotechnical Design Statement and should be appropriate for the proposed end use and foundation type. Load-settlement zone load tests should be a minimum of 1.2 times the anticipated design load of the foundations and with the loaded area of a comparable scale.

4.6.12.4 Settlement measurement

Settlement measurement of load tests or surface points should be undertaken by a suitably qualified land surveyor to a suitable accuracy, no greater than to the millimetre and less where site conditions are considered appropriate or are likely to reduce uncertainty and the required duration of monitoring. It is critical that over the long term, survey points are not damaged, disturbed, or affected by other activities. Additionally, the data should be related to stable datum outside the influence of any earthworks or Made Ground or existing unstable ground. A minimum of two datum points should be established to provide redundancy in case one is lost or damaged.

Extensometers in boreholes can be effective at determining the depth at which settlements are occurring where preloading or surcharge mounds are positioned upon underlying ground and self-weight consolidation is being assessed.

Plates with extension rods also provide means of measurement of settlement at sub formation and the underlying ground.

Settlement data should be plotted at both natural time and logarithm time to aid assessment of the data.

4.6.12.5 Testing frequency

The frequency of testing for classification, compliance and performance purposes should be determined according to site conditions, fill materials and their consistency, filling techniques and the proposed end use as stated in the earthworks specification. Testing frequencies should be specified in accordance with industry guidance such as BRE 427 and also see additional guidance within Clause 4.6.1.

Where a Method Specification is utilised, in situ testing is required but typically would be based on the total volume of engineered fill to confirm that the degree of compaction achieved by the adopted method on site is as expected. When End Product specification is utilised, in situ testing should be based on a minimum number and grid with each and every layer tested, eg, 1 per 25m x 25m grid per layer and a minimum of 3 per layer per day. Where a performance specification is adopted, it will be necessary to undertake performance testing during fill placement, as well as upon completion, to ensure compliance with the earthworks specification.

The testing frequency based on Table 10 is generally considered as an acceptable minimum requirement.

Table 10: End Product compliance testing of placed engineered fill*

Fill volume (m ³)	Minimum no. of tests required
>100,000	2no. per 1,000m ³
10,000 to 100,000	3no. per 1,000m ³
<10,000	5no. per 1,000m ³

*Note: Variation to the above may be necessary where differing material types or foundations are to be used.

Test types and frequencies should be reviewed according to the results obtained and site conditions. Where there is greater variation in site conditions or results than anticipated, an increased frequency of testing will be required. Conversely and where agreed with NHBC, a decrease in test frequency may be acceptable where consistency in test results is being achieved.

4.6.13 Reporting

Also see: BS EN 16907-5 and BS 6031

A detailed Earthworks Verification Report shall be provided to the NHBC on completion of the earthworks filling and testing. Where appropriate, the contents shall be agreed with the NHBC prior to the work being done.

A comprehensive Earthworks Verification Report for the filling works should be provided to the NHBC as soon as practicable. It should provide an interpretation and assessment of the factual data contained within the report as well as a detailed summary of the works undertaken including testing. A site wide or phased reporting approach is acceptable.

Where reinforced strip foundations are proposed, the report should be produced by a third-party organisation separate from those undertaking the works, ie, by the overseeing supervising engineer, with all factual information made available. The report, where beam grillage or semi-raft foundations are proposed, can be produced solely by a suitably experienced earthworks contractor.

The content of the Earthworks Verification Report shall be defined within the earthworks specification. Guidance on the contents and structure of the detailed report may be based on information within DRMB CD 622, where it is termed a Geotechnical Feedback Report.

It is important that the report is in an appropriate format. Test results should be suitably summarised and presented to provide clear understanding using graphs and charts as necessary.

The Earthworks Verification Report should give details as appropriate of the following:

1. The contractors and personnel responsible for the filling work including details of supervision and testing
2. Preparation works prior to earthworks filling
3. Reference to the earthwork specification and method statement(s)
4. Sources of material used as engineered fill and their material classification
5. Any treatment, reconditioning or remediation of proposed engineered fill
6. Plant and methods used
7. As built survey records including post topsoil strip level or formation level for the earthworks, reduced levels following earthworks cuttings, final as-built or post earthworks filling formation level, plan(s) and other drawings as appropriate that show the extent and depth of earthworks filling
8. All test results and certificates
9. Progress photographs and surveys
10. Progress reports, site diaries, with details of weather/site conditions and any agreed variations or changes to the specification
11. Graphical representation of the classification and compliance test data as show in Figure 7 below
12. Changes and amendments to design and earthworks specification
13. Records of remedial actions in areas of non-compliance
14. Problems experienced and solutions and methods used to overcome the issues
15. Confirmation that the works comply with the earthworks specification and are suitable to support the proposed foundation types, where applicable. All non-compliances or departures from the earthworks specification should be clearly identified and suitably assessed
16. Drawings showing known obstructions and any relevant features under or within the engineered fill
17. Graphical representation of the load-settlement tests, surcharge trials or post-completion monitoring over time with plots of settlement versus natural and log time presented to demonstrate that primary settlements are complete, with a clear trend of any remaining creep settlement projected to allow for a satisfactory building performance over a 60-year design life
18. Information required by the builder to safely undertake follow-on works in the ground including any special precautions which should be undertaken or unusual constraints that exist, and any residual risks for example further measures may be required where upfilling or an increase in ground levels post-remediation are likely to be proposed

Figure 7: Basis for design: Plot of moisture contents vs dry densities for each fill type

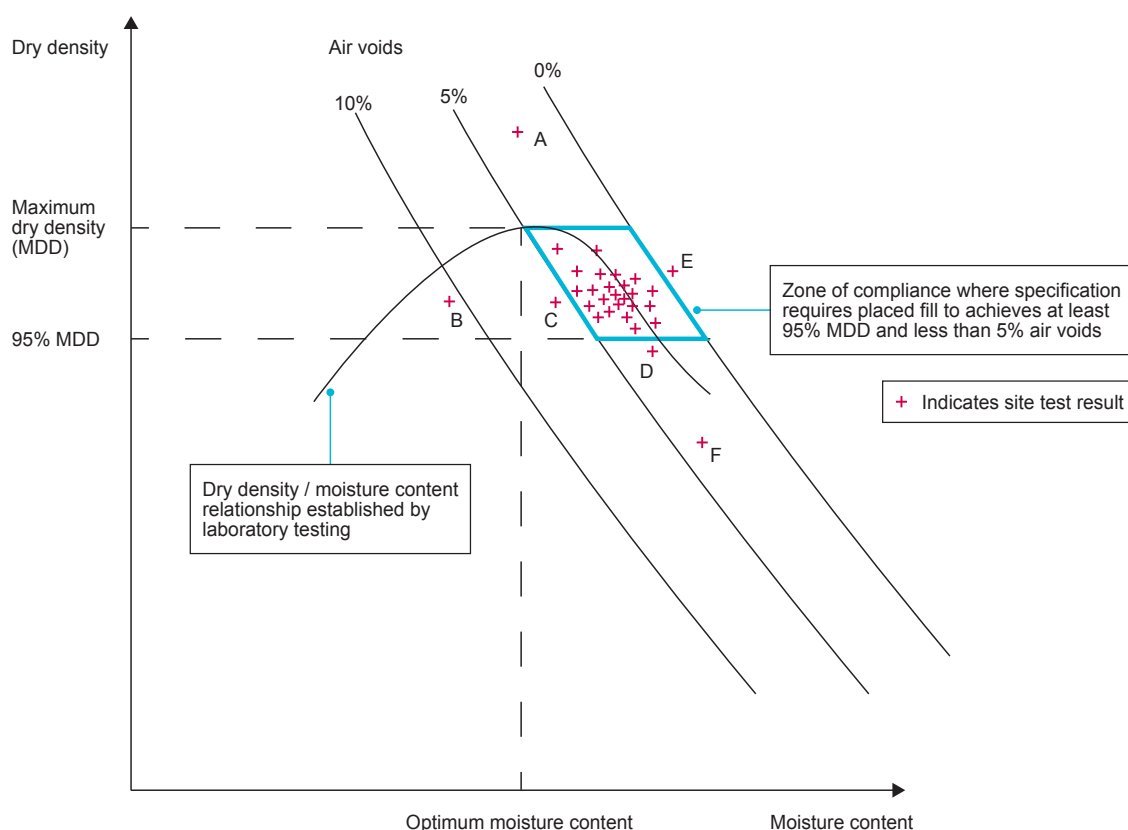

Notes:

A – Indicates placed fill is of significantly higher density than achieved in the laboratory – the fill classification is likely not complying with the specification. Repeated results higher than the MDD indicates the laboratory testing was not on representative material or the method of laboratory compaction was too light.

B – Indicates placed fill has been compacted too dry of optimum and may therefore, where cohesive fill has been used, be liable to settlement when wetted.

C, D & E – Marginally outside of the compliance zone. As part of a large set of results that are otherwise compliant these marginal failures may be acceptable provided, they are not part of non-compliant clusters.

F – Indicates fill placed wet of optimum and may be liable to settlement under load or over time.

Results of type A, B & F should be assessed further, and explanation provided of remedial actions, further testing or reasons for acceptance.

Further guidance on acceptability testing of proposed source fills and compliance testing of placed engineered fill is provided in BS 6031:2009. In setting the compliance curve of dry density/moisture content relationship all tests should be presented/ or made available such that the target basis of design (for each fill type) can be agreed with NHBC, noting the degree of interpretation and assessment including outliers. Updated targets may be appropriate in variable materials and should be detailed and agreed with the NHBC.

Compliance test results should be summarised and presented so that any non-compliances can be easily identified.

If the site has been filled some years before the intended construction works or for an alternative end use such as commercial buildings, then a retrospective validation may be appropriate. Assessment of historic fill within land reclamation schemes and marginal sites are generally outside the scope of this Chapter. Consult NHBC or consider using NHBC Land Quality Service for a bespoke consultation.

Figure reference table

Figure reference table 4.6			
Fig No	Title/Description	Clause	Page
Figure 1	Fill assessment and chapter applicability process	4.6	2
Figure 2	Compaction and differing end use	4.6.7.3	15
Figure 3	Engineered fill over gentle rolling landscape	4.6.8.3	18
Figure 4	Engineered fill over buried features	4.6.8.3	18
Figure 5	Benching of sloping natural ground	4.6.10.2	20
Figure 6	Placement of excavation adjacent foundation on engineered fill	4.6.11	22
Figure 7	Basis for design: Plot of moisture contents vs dry densities for fill type	4.6.13	27



Technical Disclaimer

The NHBC Standards are produced by NHBC as guidance solely for our builder customers as to how to interpret the technical requirements in relation to the warranty cover provided by NHBC under its Buildmark, Buildmark Choice, Buildmark Link, Buildmark Solo, Buildmark Connect or any similar product from time to time. It has not been created or intended for distribution or use outside of that purpose. The information contained in the NHBC Standards do not constitute advice and is not to be relied upon by any third party. Nothing in the NHBC Standards is intended to, nor should it be taken to, create any legal or contractual relationship. Any third party who chooses to rely upon the information contained in the NHBC Standards shall do so entirely at their own risk and NHBC accepts no duty of care or liability, however caused, in connection with its use or reliance by any third party.



Standards

2024

NHBC, NHBC House, Davy Avenue, Knowlhill, Milton Keynes, Bucks MK5 8FP

National House-Building Council (NHBC) is authorised by the Prudential Regulation Authority and regulated by the Financial Conduct Authority and the Prudential Regulation Authority in respect of carrying on its insurance business and its insurance distribution activities.

NHBC is registered in England and Wales under company number 00320784. NHBC's registered address is NHBC House, Davy Avenue, Knowlhill, Milton Keynes, Bucks, MK5 8FP. Note that only certain parts of NHBC's products and services are within the scope of UK financial services regulation. For more information on our products and services, please see our website nhbc.co.uk or your NHBC product documentation.