



Chapter 10.1



Garages

This chapter gives guidance on meeting the Technical Requirements for integral, attached and detached garages.

10.1.1	Compliance	01
10.1.2	Provision of information	01
10.1.3	Garage foundations	01
10.1.4	Garage floors	02
10.1.5	Garage walls	03
10.1.6	Resistance to fire spread	04
10.1.7	Security	05
10.1.8	Doors and windows	05
10.1.9	Garage roofs	05
10.1.10	Permanent prefabricated garages and carports	07
10.1.11	Services	07

For figure reference tables in this chapter, please go to the end of the chapter



10.1.1 Compliance

Also see: Chapter 2.1

Garages shall comply with the Technical Requirements.

Garages which comply with the guidance in this chapter will generally be acceptable.

10.1.2 Provision of information

Designs and specifications shall be produced in a clearly understandable format, include all relevant information and be distributed to the appropriate personnel.

Designs and specifications should be issued to site supervisors, relevant specialist subcontractors and suppliers, and include the following information:

- location of garages
- relevant levels, in relation to an agreed reference point
- details of foundations
- waterproofing arrangements
- construction details of the roof structure and coverings
- construction details for walls
- external and internal finishes
- services, where applicable
- type of garage or structure.

10.1.3 Garage foundations

Also see: Chapter 4.3

Garage foundations shall transmit all loads to the ground safely and without undue movement. Issues to be taken into account include:

- | | |
|---|----------------------------|
| a) hazardous ground | d) adjacent structures |
| b) type of foundation required for integral/attached garages | e) underground services |
| c) type of foundation required for detached garages and blocks of garages | f) provision for movement. |

Garage foundations should adequately support the imposed loads, taking account of ground conditions.

Further guidance is given in Chapter 4.3 'Strip and trench fill foundations'.

Hazardous ground

For foundations on hazardous ground, the following chapters are relevant:

- 4.1 'Land quality – managing ground conditions'
- 4.2 'Building near trees'
- 4.4 'Raft, pile, pier and beam foundations'
- 4.5 'Vibratory ground improvement techniques'.

Any existing fill on the site of the garage should be examined and identified. Where any potential health hazard or risk of damage is indicated, appropriate precautions should be taken, as described in the following chapters:

- 4.1 'Land quality – managing ground conditions'
- 5.1 'Substructure and ground-bearing floors'.

Type of foundation required for integral/attached garages

Foundations for integral or attached garages should be the same as those for the home, unless proper consideration is given to each foundation, and the possibility of differential movement between them.

Type of foundation required for detached garages and blocks of garages

Foundations for detached individual garages or blocks of garages should avoid damage caused by differential loads and uneven settlement.

Where the ground is uniform and provides a satisfactory foundation bearing, an unreinforced edge thickened concrete slab may be used.

Unreinforced concrete slabs should:

- have a minimum thickness of 100mm
- have a minimum downstand thickening of 350mm below ground level around the whole perimeter of the slab
- have a minimum width of edge thickening of 300mm
- be constructed on 100mm minimum of properly compacted hardcore
- have dimensions not exceeding 6m in any direction – for dimensions greater than this, movement joints should be provided.

Figure 1: Specifications for unreinforced concrete slabs

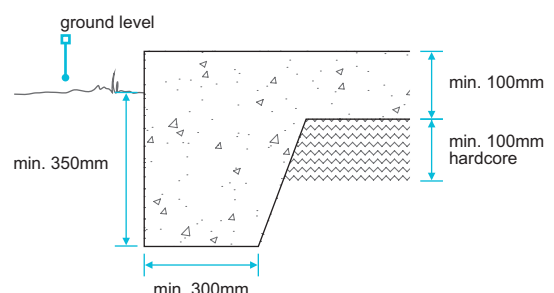

Adjacent structures

Foundations for garages should not impair the stability of the home or any other adjacent structure.

Underground services

Garage foundations that are to be above or near services should be constructed so that no excessive settlement of foundations or damage to services occurs (see Chapter 5.3 'Drainage below ground').

Provision for movement

Movement joints in foundations should be provided:

- between homes and attached garages where there is a change of foundation type
- at 6m intervals where unreinforced concrete slab foundations are used.

10.1.4 Garage floors

Also see: Chapter 5.1, 5.2

Garage floors shall transmit all loads to either the foundations or the ground safely and without undue movement. Issues to be taken into account include:

- a) bearing capacity of the ground
- b) resistance of the floor to moisture from the ground
- c) resistance of the floor to hazardous gas
- d) thickness of floor slabs
- e) floor drainage
- f) structural topping
- g) construction joints.

Garage floors will be acceptable where they are in accordance with any of the following:

- Chapter 5.1 'Substructure and ground-bearing floors'
- Chapter 5.2 'Suspended ground floors'
- the guidance given in this chapter.

Unless ventilation is specifically required, the void beneath a garage floor which is suspended precast concrete may be unventilated where:

- the floor has adequate durability
- the ground beneath is well drained
- there is unlikely to be a build-up of soil gases.

Bearing capacity of the ground

Where the depth of fill exceeds 600mm, concrete floors should be in accordance with Chapter 5.2 'Suspended ground floors' and BS 8103-1.

Supporting fill should comply with the requirements in Chapter 5.1 'Substructure and ground-bearing floors'.

Where protection is needed to prevent attack by sulfates in either the ground, ground water or fill below the slab, an impervious isolating membrane should be provided between the concrete and the ground.

Resistance of the floor to moisture from the ground

Generally, a DPM is unnecessary, except where:

- it is needed to prevent dampness entering the home, or
- the floor has to be protected against chemical attack from the ground.

Where no DPM is provided, the floor may show signs of dampness.

Where the floor is below ground level, precautions should be taken to prevent the entry of ground water, and tanking may be required.

Resistance of the floor to hazardous gas

Where hazardous gas precautions are required and a property includes either an integral or attached garage, notwithstanding the inclusion or omission of a connecting doorway or absence or presence of habitable accommodation above the garage, the hazardous gas precautions should be continuous to the garage(s) and extend to the perimeter of the property.

Membranes should not be exposed and be protected against physical damage.

Following a site specific risk assessment and specialists advice, detached garages may also require hazardous gas precautions.

Thickness of floor slabs

Ground-bearing floors, where provided, should not be less than 100mm thick, including a float finish.

Floor drainage

When practicable, garage floors should be laid to falls to ensure that water or spillage is directed out of the garage via the vehicle doorway.

Structural topping

Where reinforced screeds are to be incorporated as structural topping, they should be designed by an engineer in accordance with Technical Requirement R5.

Construction joints

If the floor area of a garage exceeds 16m^2 then:

- either the floor slab should be reinforced or
- construction joints should be provided which equally divide the floor area into bays less than 16m^2 .

Figure 2: Construction joints in unreinforced concrete floor slabs

Double Garage (Double Width)

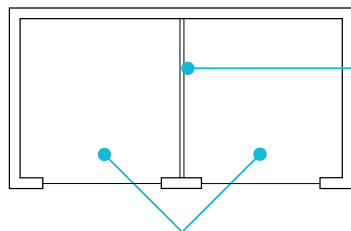

Individual bay areas less than 16m^2

Construction joint along length of garage at mid width

Construction joint across width of garage at mid length

Double Garage (Double Length)

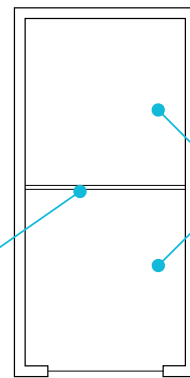

Individual bay areas less than 16m^2

Examples of unreinforced concrete floors in garages where total floor area exceeds 16m^2 .

10.1.5 Garage walls

Walls for garages shall transmit all loads to foundations safely and without undue movement. Issues to be taken into account include:

- | | |
|--|--|
| a) stability of walls above ground | c) provision for movement |
| b) stability of walls retaining ground | d) adequate resistance to rain and ground water. |

Garage walls will be acceptable where they are in accordance with any or a combination of the following:

- Chapter 5.1 'Substructure and ground-bearing floors'
- Chapter 6.1 'External masonry walls'
- the guidance given below.

If integral garages are formed within a timber frame building, the construction of the garage walls should be in accordance with Chapter 6.2.

Stability of walls above ground

Walls for detached garages and external walls for attached garages should:

- be not less than 90mm thick
- have adequate lateral restraint against wind loading.

Piers should be located in single leaf walls:

- up to 200mm thick
- at corners, unless buttressed by a return of at least 390mm
- which are greater than 2.5m in length or height and which do not contain a major opening ie, garage door
- at intermediate centres not exceeding 3m
- either side of a major opening ie, garage door.

Piers should also:

- be built off the foundation
- extend the full height of the wall
- measure at least 390mm x 190mm or 327mm x 215mm depending upon masonry unit size
- be bonded or tied to walls with flat stainless steel wall ties, 20mm x 3mm in cross section, placed in pairs and not more than 300mm centres vertically.

Stability of walls retaining ground

Garage walls retaining ground should be:

- suitable for the ground conditions
- structurally adequate.

Where garage walls act as retaining walls, they should be designed in accordance with Chapter 5.1 'Substructure and ground-bearing floors' or by an engineer in accordance with Technical Requirement R5.

Provision for movement

Movement joints in garage walls, as described in BS EN 1996-2, should be provided:

- between homes and attached garages
- where there are movement joints in foundations.

Adequate resistance to rain and ground water

To protect the wall from rising ground moisture, a DPC should be provided at a level at least 150mm above the level of adjacent ground.

Garage walls constructed from a single leaf of masonry, such as brickwork or blockwork approximately 100mm thick, will not be impervious to wind-driven rain and consequently could become damp.

In areas of severe exposure or worse, single leaf walls may require a high standard of workmanship and possibly surface treatment to prevent an unacceptable level of rain penetration.

Where a cavity wall is to be used as an alternative to surface treatment of a single leaf wall, it would be acceptable to use a cavity of less than 50mm in this instance.

Where a garage is integral or attached, the design should ensure that dampness cannot enter the home.

Where a wall is below ground level, precautions should be taken to prevent the entry of ground water by:

- tanking (see Chapter 5.4 'Waterproofing of basements and other below ground structures')
- the use of DPCs and DPMs
- drainage of ground behind the wall.

10.1.6 Resistance to fire spread

Garages shall be constructed so as to prevent fire spread to the home from the garage.

Fire resistance between homes and integral or attached garages, may be provided by:

- a fire-resisting wall in brickwork, blockwork or studwork up to the underside of the roof covering (minimum REI 30) with junctions fire-stopped
- a fire-resisting floor or ceiling (minimum REI 30)
- constructions where 30 minutes fire resistance can be proven.

Doors between homes and attached/integral garages should be fire doors and be fitted with a self-closing device. Consult relevant Building Regulations for performance requirements.

Figure 3: Fire-resisting masonry wall between garage and dwelling

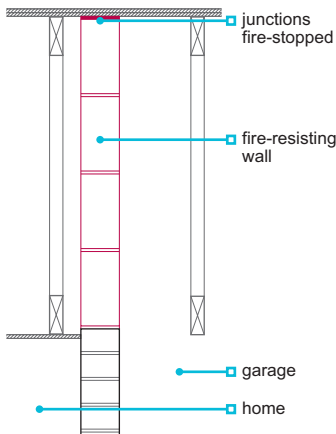

Figure 4: Fire-resisting timber wall between garage and dwelling

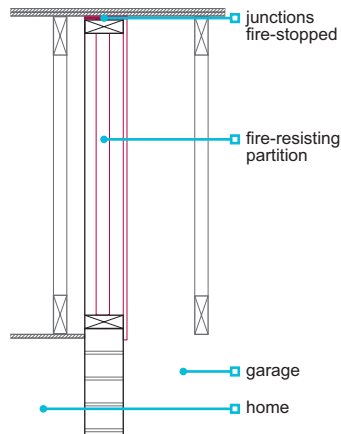
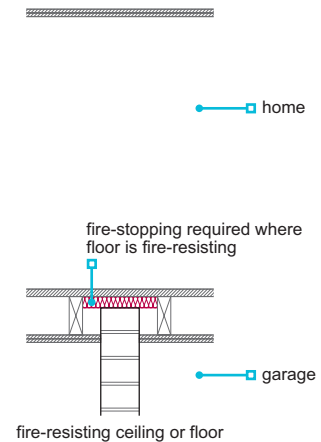

Figure 5: Fire-resisting ceiling or floor between garage and dwelling



10.1.7 Security

Garages shall be constructed to provide reasonable security against unauthorised entry, in particular where garages are linked.

Where garages of different ownership are linked, walls should prevent direct access from one garage to another.

The following should provide adequate security:

- walls – masonry construction, or timber frame with two layers of plasterboard on each side
- walls where fire resistance is not required – timber frame with one layer of 6mm plywood or 9mm OSB on each side.
- ceilings – two layers of plasterboard

10.1.8 Doors and windows

Garage doors and windows shall be adequate for their purpose. Issues to be taken into account include:

a) robustness

b) ease of operation.

Doors and windows will be acceptable where they are in accordance with Chapter 6.7 'Doors, windows and glazing'.

Robustness

Frames should be selected and fixed having taken into account the type and weight of the garage door.

Ease of operation

Proprietary doors and door gear should be installed in accordance with the manufacturer's recommendations.

Care should be taken to ensure that garage doors are in proper working order at handover.

10.1.9 Garage roofs

Also see: Chapter 7.2

Garage roofs shall satisfactorily resist the passage of rain and snow to the inside of the building, support applied loads and self-weight, and transmit the loads to the walls safely and without undue movement. Issues to be taken into account include:

- a) holding down
- b) bracing
- c) restraint

- d) detailing at abutments
- e) movement
- f) adequate disposal of rainwater.

Garage roofs will be acceptable where they are in accordance with:

- Chapter 7.1 'Flat roofs, terraces and balconies', or
- Chapter 7.2 'Pitched roofs'.

Holding down

To prevent uplift, flat roofs and, where necessary, pitched roofs should be provided with holding-down straps at not more than 2m centres where the roof members bear on the supporting wall.

Holding down straps should be:

- provided where the roof pitch is below 15° or the roof has a lightweight covering with a laid mass of less than 50 kg/m²
- where local experience suggests there is a risk from wind gusts
- provided in accordance with the design
- a minimum cross-section of 30mm x 2.5mm (galvanised steel straps are generally acceptable) or proprietary straps and fixings
- at least 1m long and have three fixings to the wall, or turned into a bed joint.

Bracing

The building designer should specify all bracing. Trussed rafter roofs should be braced in accordance with Chapter 7.2 'Pitched roofs', unless the roof is designed and braced in accordance with PD 6693-1.

All timber bracing to trussed rafters should be at least 100mm x 25mm in section and nailed twice to each trussed rafter. Nailing should be 3.35mm (10 gauge) x 65mm long galvanized round wire nails.

Restraint

For garages of masonry construction, the gable should be restrained at rafter level with restraint straps. Restraint should also be provided at ceiling level where the height (h) exceeds:

- 16 x thickness of the wall for single leaf walls
- 16 x sum of thickness of leaves + 10mm for cavity walls.

Note: 'h' should be measured from the top of foundations or from the underside of the floor slab where this provides effective lateral restraint.

Figure 6: Calculating gable height

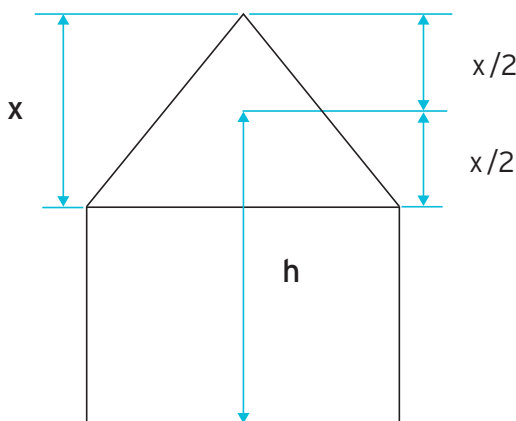

The restraint at rafter level may be provided by restraint straps or by a gable ladder.

Where straps are used they should have a minimum cross section of 30mm x 5mm or be proprietary straps that have been designed for lateral restraint purposes. Straps should be fixed to rafters with solid blocking (or be fixed to the longitudinal bracing (see Clause 7.2.8).

For cavity walls the straps should be at 2m maximum centres, with the top strap near the apex of the gable. For solid walls it will normally be necessary to fix the straps to the inside face with at least two 6mm x 30mm plug and screw fixings per strap.

Unless the design states otherwise, the restraint straps should be provided at the following positions:

- walls constructed of solid bricks – two restraint straps per roof slope at maximum 2m centres plus one extra strap near the apex of the gable
- walls construction of perforated bricks/blocks or concrete/aerated concrete blocks – three restraint straps per roof slope at maximum 1.5m centres.

Note: For the purpose of lateral restraint, a 'perforated' brick/block is where the perforations (vertical holes) represent more than 25% of the volume of the brick/block.

Detailing at abutments

Precautions should be taken at abutments between a garage roof and the main building or between stepped garages, including:

- flashings and weatherproofing that allow for differential movement
- cover flashings formed from metal or other approved material
- cavity trays that divert water from inside the cavity to the external surface of the roof.

Movement

Movement joints in foundations and the structure should be continued through roof coverings and be provided with appropriate weather protection.

Adequate disposal of rainwater

The provision of rainwater should be in accordance with Building Regulations.

Individual roofs, or combinations of roofs that drain from one to another, with a total area greater than 6m², should have a rainwater drainage system.

Where rainwater from a large roof surface discharges onto a garage roof, precautions should be taken to prevent premature erosion of the lower surface.

Rainwater should not discharge from the roof directly to a drive or path.

For details on the design of rainwater disposal systems, reference should be made to the following chapters, as appropriate:

- 7.1 'Flat roofs, terraces and balconies'
- 7.2 'Pitched roofs'

10.1.10 Permanent prefabricated garages and carports

Permanent prefabricated garages and carports shall be suitable for their intended purpose.

Permanent prefabricated garages and carports should:

- have appropriate foundations
- be structurally adequate
- provide appropriate weathertightness
- provide adequate separation between linked garages of different ownership.

Prefabricated garages should be erected in accordance with the manufacturer's recommendations.

Particular care should be taken to ensure adequate holding down of carports and other light structures against wind action.

10.1.11 Services

The provision of any service or appliance within a garage shall be in accordance with relevant regulations. Issues to be taken into account include:

- a) protection of water services against frost
- b) provision of electricity
- c) risk of fire or explosion.

Where services or appliances are provided in garages, they should comply with the guidance below and with the following chapters, as appropriate:

- 5.3 'Drainage below ground'
- 8.1 'Internal services'.

Protection of water services against frost

A rising main should not be located within a garage.

A water supply or outlet in a garage should have adequate provision for isolating and draining down.

Pipes should be insulated and located so as to minimise the risk of freezing.

Provision of electricity

The provision of electric lighting and socket outlets in a garage is at the discretion of the builder.

All electrical installations should comply with BS 7671 'Requirements for Electrical Installations. IET Wiring Regulations'.

Where there is a risk of rain penetration through garage walls, electrical wiring and equipment should be appropriate for the location and take account of conditions likely to be expected. For further guidance see Clause 8.1.6.

Risk of fire or explosion

Installation in a garage of an oil or gas burning boiler or heating appliance should be in accordance with any relevant statutory regulations.

Where garages are to contain solar storage batteries, see Clause 8.2.1.

Figure reference table

Figure reference table 10.1

Fig No	Title/Description	Clause	Page
Figure 1	Specifications for unreinforced concrete slabs	10.1.3	1
Figure 2	Construction joints in unreinforced concrete floor slabs	10.1.4	3
Figure 3	Fire-resisting masonry wall between garage and dwelling	10.1.6	5
Figure 4	Fire-resisting timber wall between garage and dwelling	10.1.6	5
Figure 5	Fire-resisting ceiling or floor between garage and dwelling	10.1.6	5
Figure 6	Calculating gable height	10.1.9	6



Chapter 10.2



Drives, paths and landscaping

This chapter provides guidance on meeting the Technical Requirements for drives, paths and landscaping, including:

- private roads
- shared private drives
- private drives
- car parking areas.

10.2.1	Compliance	01
10.2.2	Provision of information	01
10.2.3	Stability	01
10.2.4	Freestanding walls and retaining structures	01
10.2.5	Guarding and steps	02
10.2.6	Drives, paths and landscaping	02
10.2.7	Materials	07
10.2.8	Garden areas within 3m of the home	08
10.2.9	Garden areas	08
10.2.10	External decking	08
10.2.11	Landscaping	08

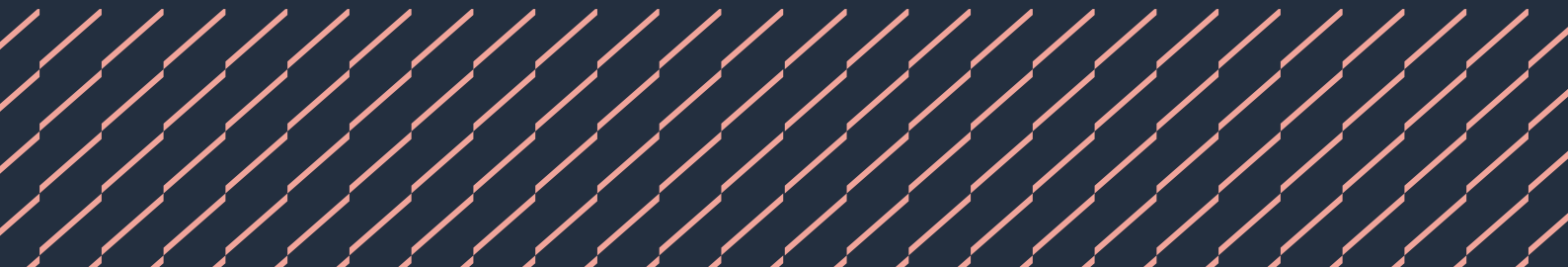

Definitions for this chapter

Commercial vehicles	Commercial vehicles are typically vehicles weighing in excess of 3.5 tonnes or capable of moving a payload of more than 1 tonne. Examples are delivery trucks, buses, large vans, bin lorries, and fire trucks.
Flexible retaining walls	Are typically walls that support the soil laterally and allow larger deformations of the unsupported edge of the wall compared to stiff or rigid retaining walls. Typical examples of these include any or a combination of the following: vegetated such as geotextile bagged walls, earth-reinforced and most gravity retaining wall structures such as gabion, crib, block or modular retaining wall systems.
Garden	Is the land within the curtilage up to 20m from the habitable parts of the home (ie, not garages/ outbuildings). This distance is measured from the external walls.
Home	Includes a house, bungalow, flat or maisonette.
Light vehicles	Light vehicles are typically vehicles weighing up to 3.5 tonnes, and these include cars, SUV's, vans and minibuses.
Private drives	Are usually located adjacent to a property and typically within the curtilage of that property. Private drives and parking areas where located away from the immediate vicinity of a properties would usually have a barrier to ensure it is only used by cars and or light vehicles.
Private roads	Are roads that are unadopted or not maintained at public expense. They are usually wide enough for single traffic in opposite directions simultaneously, and may or may not have adjoining footpaths. Private roads will be expected to support frequent use by commercial vehicles.
Shared drives	Are usually single track private 'roads' to access private drives or private properties. Shared drives would be expected to support the occasional commercial vehicles on them.
Shared parking	Are typically communal parking area, which is accessible to the general public but are not adopted. There is usually little or no restriction regarding what type vehicles they are accessible to. They can sometimes act a turning head at the end of a public/ adopted road. Shared parking and access road/ areas to them are expected to support frequent use by commercial vehicles.

10.2.1 Compliance

Also see: Chapter 2.1

Drives, paths and landscaping shall comply with the Technical Requirements.

Drives, paths and landscaping that comply with the guidance in this chapter will generally be acceptable.

All works should be completed in accordance with:

- the design, and
- the ground remediation statement (where applicable).

Formation levels should be set out in accordance with the design.

10.2.2 Provision of information

Designs and specifications shall be produced in a clearly understandable format, include all relevant information and be distributed to the appropriate personnel.

All works relating to drives, paths and landscaping should be fully specified.

Designs and specifications should be issued to site supervisors, relevant specialist subcontractors and suppliers.

10.2.3 Stability

Precautions shall be taken to ensure stability of the ground.

Where the ground may become surcharged during construction, precautions should be taken to ensure stability.

Flexible retaining walls such as gabion and timber structures should not be used to provide support to homes, garages, roads, drives, car parking areas or drainage systems.

Retaining structures that give support to the foundations of a home should be completed before work starts on the construction of the foundations of the home.

10.2.4 Freestanding walls and retaining structures

Freestanding walls and retaining structures shall be adequate for their intended purpose.

Freestanding walls should be in accordance with:

- BS EN 1996-1 'Design of masonry structures'
- PD 6697 Recommendations for the design of masonry structures.

Retaining structures should be in accordance with:

BS 8002	'Code of Practice for earth retaining structures'.
BS EN 1992	'Design of concrete structures'.
BS EN 1996	'Design of masonry structures'.
BS EN 1997-2	'Geotechnical design. Ground investigation and testing'.
BRE Good Building Guide 27	'Building brickwork and blockwork retaining walls'.

All retaining structures, more than 600mm high, should be designed by an engineer in accordance with Technical Requirement R5.

Where timber structures more than 600mm high are used for retaining ground in boundary situations, they should be designed with a desired service life of 60 years and have a satisfactory third-party certification from an approval body acceptable to NHBC.

Where planters are provided, they should be designed to support the volume of retained soil and the plant species.

10.2.5 Guarding and steps

Retaining structures and steps shall be adequately guarded and allow safe use.

Guarding should be provided where:

- structures are retaining land more than 600mm high to which people have access
- a retaining structure is more than 600mm high and the dimension from the top of the retaining wall to the higher ground level is less than 300mm, or
- a path is adjacent to a vertical difference in level of more than 600mm (including where ground adjacent to the path falls away at an angle of more than 30° from the horizontal).

The guarding should:

- be a minimum of 1100mm high
- not be readily climbable by children
- not allow a 100mm diameter sphere to pass through
- be capable of resisting a horizontal load of at least 0.36kN/m at its minimum required height, in accordance with BS 6180.

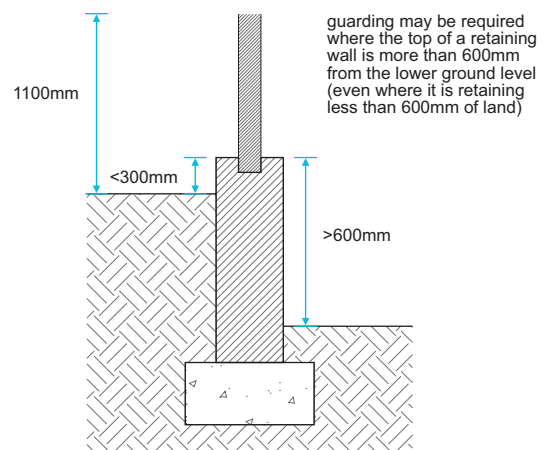

External steps that are not considered under Building Regulations should:

- have a maximum rise of 220mm
- have a minimum going of 220mm
- be reasonably uniform.

A handrail should be provided where the total rise of a flight of external steps is more than 600mm and the going of individual steps is less than 600mm.

For details of external staircases in and around dwellings, see Chapter 6.6 of this Standard.

Guidance for the provision of handrails to steps that form an accessible approach can be found in supporting documents to Building Regulations.

10.2.6 Drives, paths and landscaping

Appropriate access (including private roads, shared private drives, private drives, car parking and paths) shall be provided to and around the home. Issues to be taken into account include:

- | | |
|--|-------------------------------|
| a) general construction considerations | d) minimum sub-base thickness |
| b) drainage | e) house paths and patios. |
| c) construction details | |

Homes should be provided with suitable access through the provision of private roads, shared private drives, private drives, car parking areas and paths, as appropriate.

General construction considerations

Private roads, shared private drives, private drives, car parking areas and paths should comply with relevant building regulations.

Where abutting the home, they should be at least 150mm below the DPC, and laid to falls away from the home (unless a channel or other suitable means of collection and disposal is provided).

All vegetable matter should be removed from the area of the proposed works.

Only suitable fill material comprising clean, well-consolidated crushed rock, hardcore, slag or concrete should be used to make up levels.

Sub-bases should be mechanically consolidated in layers not exceeding 225mm.

Finished ground levels should be compatible with:

- DPC levels
- cover levels of drainage access points
- depth of underground services (gas, electricity, water and drains)
- adjacent surfaces.

Private roads, shared private drives and private drives should:

- be appropriate for the loads
- provide reasonable access to and from a garage or car parking area
- have a maximum gradient of 1:6
- where the gradient is more than 1:10 and the gradient changes, have suitable transition lengths to reduce the risk of vehicles grounding.

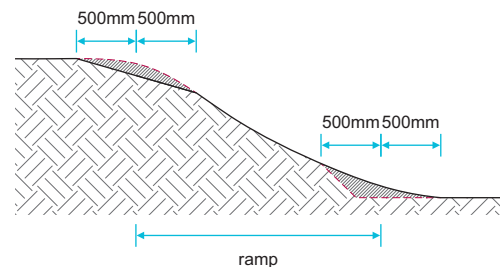

Underground drainage or services that are below a private road, shared private drive, private drive, car parking area, path or patio should be protected against damage, as described in Chapter 5.3 'Drainage below ground'.

Edge restraint or kerbing should have a profile and foundation, which is suitable to form a permanent supporting edge for the expected vehicle loads on the road or drive.

Pedestrian access should be provided via a path within the curtilage of each home to the main entrance and the secondary entrance where present:

- where entry to the home can be gained directly from a garage, a path to a secondary access door is not required
- where the secondary entrance is to a mid-terrace home or ground floor flat, a path to a secondary access door is not required
- where a garage, carport or car parking area is provided within the curtilage, a path should be provided to it from the home.

Where appropriate, a drive can be regarded as a path for the provision of access.

Paths should have a maximum slope of 1:6. On steeper sloping ground, steps may be required.

Table 1: Suitable path widths

Location and use	Minimum width of hard standing (mm)	Minimum overall width (mm)
Within curtilage to main entrance, or any entrance designated by Building Regulations.	900	900
Paths used for the removal of refuse to the collection point.	750	900
Paths adjoining a home (with hard standing 100mm or more from the wall of the home).	450	700
All other cases.	450	600

Drainage

Private roads, shared private drives and private drives should have adequate rainwater drainage and disposal.

Paved areas should:

- have vertical alignment, finished levels, transition arrangements and gradients in accordance with the design
- have surfaces with adequate falls, cross-falls and drainage to ensure that surface water is suitably drained
- have sub-base levels with the same longitudinal gradient and cross-fall as the finished level
- have surfaces not flatter than 1:40 or have a camber of 1:40 where no fall is available to avoid 'flat spots'
- have surfaces with a minimum finished fall of 1:80 where they form private drives and paths
- drain away from the home (and garage), or drain to a channel or other suitable means of collection and disposal adjacent to the home
- not drain surface water from private areas onto adopted areas
- not be within 2m of a soakaway.

Where paving slabs are laid abutting drainage channels and gully grates, etc, the upper surface of the paving slab should be set approximately 5mm above the grating.

Where it is intended to use porous or permeable surfaces as part, or all, of the rainwater drainage system, reference should be made to CIRIA report C753 - The Sustainable drainage system (SuDS) manual.

Construction details

The construction of private roads, shared private drives, private drives and car parking areas should be constructed in accordance with the tables below and/or other published/approved design procedure.

Table 2a: Private road having frequent use by commercial vehicles

Construction – road type ⁽¹⁾		Road		Footpath
		Bituminous mixtures (asphalt)	Block pavers	Bituminous mixtures
Sub-base	MCHW Volume 1 SHW Clause 803 Type 1 Unbound mixtures Granular sub-base material Type 1 to table 8/2	Table 3	Where California Bearing Ratio (CBR) is 5% or less = 150 ⁽³⁾ Where CBR is greater than 5% = Table 3	225mm ⁽³⁾
Base (road base)	Asphalt concrete to BS EN 13108-1 and PD 6691 utilising aggregate to BS EN 13043 and PD 6682-2	100mm (AC 32 dense base 100/150 des)	N/A	N/A
	Concrete designation (BS 8500-2:2015+A2:2019 table 6)	N/A	N/A	N/A
Binder course (base course)	Asphalt concrete to BS EN 13108-1 and PD 6691 utilising aggregate to BS EN 13043 and PD 6682-2	60mm (AC 20 dense bin 100/150 des)	60mm (AC 20 dense bin 100/150 des)	60mm (AC 20 dense bin 100/150 des)
Surface course (wearing course)	Stone mastic asphalt to BS EN 13108-5 and PD 6691 with aggregate to BS EN 13043 and PD 6692-2	30mm (SMA 10 surf 40/60)	N/A	20mm (AC 6 dense surf 100/150 des)
	Hot rolled asphalt to BS EN 13108-4 and PD 6691 utilising aggregate to BS EN 13043 and PD 6692-2	40mm (HRA 55/10 surf 40/60 des)	N/A	N/A
	Concrete designation (BS 8500-2:2015+A2:2019 table 6)	N/A	N/A	N/A
Bedding course	Coarse sand to BS 7533-3 category II of annex D	N/A	50mm	N/A
Pavers	Block pavers to BS EN 1338 of Class 2 weathering resistance and Class 3 abrasion, as well as being of low potential for slip (Ref: Table NA.2 of BS EN 1338) ⁽⁷⁾	N/A	80mm	N/A

Table 2b: Shared parking and associated access areas having frequent use by commercial vehicles

Construction – road type ⁽¹⁾		Bituminous mixtures (asphalt)	Block pavers
Sub-base	MCHW Volume 1 SHW Series 800 (2) Clause 803 Type 1 Unbound mixtures granular sub-base material Type 1 to table 8/2	Table 3	Table 3
Base (road base)	Asphalt concrete to BS EN 13108-1 and PD 6691 utilising aggregate to BS EN 13043 and PD 6682-2	80mm (AC 32 dense base 100/150 des)	N/A
	Concrete designation (BS 8500-2:2015+A2:2019 table 6)	100mm grade GEN2 ⁽⁴⁾	N/A
Binder course (base course)	Asphalt concrete to BS EN 13108-1 and PD 6691 utilising aggregate to BS EN 13043 and PD 6682-2	60mm (AC 20 dense bin 100/150 des)	N/A
Surface course (wearing course)	Stone mastic asphalt to BS EN 13108-5 and PD 6691 utilising aggregate to BS EN 13043 and PD 6682-2	30mm (SMA 10 surf 40/60)	N/A
	Hot rolled asphalt to BS EN 13108-4 and PD 6691 utilising aggregate to BS EN 13043 and PD 6682-2	N/A	N/A
	Concrete designation (BS 8500-2:2015+A2:2019 table 6)	N/A	N/A
Bedding course	Sharp sand to BS 7533-3 category II of annex D	N/A	50mm
Pavers	Block pavers to BS EN 1338 of Class 2 weathering resistance and Class 3 abrasion, as well as being of low potential for slip (Ref: Table NA.2 of BS EN 1338) ⁽⁷⁾	N/A	80mm

Table 2c: Shared drives having infrequent use by commercial vehicles

Construction – road type ⁽¹⁾		Bituminous mixtures (asphalt)	Concrete	Block pavers	Gravel
Sub-base	MCHW Volume 1 SHW Series 800 ⁽²⁾ Clause 803 Type 1 Unbound mixtures granular sub-base material Type 1 to table 8/2	Table 3	Table 3	Table 3	Table 3
Base (road base)	Asphalt concrete to BS EN 13108-1 and PD 6691 utilising aggregate to BS EN 13043 and PD 6682-2	⁽⁵⁾	N/A	N/A	N/A
	Concrete designation (BS 8500-2:2015+A2:2019 table 6)	N/A	N/A	N/A	N/A
Binder course (basecourse)	Asphalt concrete to BS EN 13108-1 and PD 6691 utilising aggregate to BS EN 13043 and PD 6682-2	80mm (AC 20 dense bin 100/150 des ⁽⁶⁾)	N/A	N/A	N/A
Surface course (wearing course)	Stone mastic asphalt to BS EN 13108-5 and PD 6691 utilising aggregate to BS EN 13043 and PD 6682-2	30mm (SMA10 surf 40/60)	N/A	N/A	N/A
	Hot rolled asphalt to BS EN 13108-4 and PD 6691 utilising aggregate to BS EN 13043 and PD 6682-2	40mm (HRA 55/10 surf 40/60 des)	N/A	N/A	N/A
	Concrete designation (BS 8500-2:2015+A2:2019 table 6)	N/A	150 grade PAV2	N/A	N/A
Bedding course	Sharp sand to BS 7533-3 category II of annex D	N/A	N/A	50mm	N/A
Pavers	Block pavers to BS EN 1338 of Class 2 weathering resistance and Class 3 abrasion, as well as being of low potential for slip (Ref: Table NA.2 of BS EN 1338) ⁽⁷⁾	N/A	N/A	80mm	N/A

Table 2d: Private drives and parking areas having use by cars and light vehicles

Construction - road type ⁽¹⁾		Bituminous Mixtures (asphalt)	Concrete	Block pavers	Gravel
Sub-base	MCHW Volume 1 SHW Series 800 ⁽²⁾ Clause 803 Type 1 Unbound mixtures granular sub-base material Type 1 to table 8/2	Table 3	Table 3	Table 3	Table 3
Base (road base)	Asphalt concrete to BS EN 13108-1 and PD 6691 utilising aggregate to BS EN 13043 and PD 6682-2	N/A	N/A	N/A	N/A
	Concrete designation (BS 8500-2:2015+A1:2019 table 6)	N/A	N/A	N/A	N/A
Binder course (base course)	Asphalt concrete to BS EN 13108-1 and PD 6691 utilising aggregate to BS EN 13043 and PD 6682-2	60mm (AC 20 dense bin 100/150 des)	N/A	N/A	N/A
Surface course (wearing course)	Asphalt concrete to BS EN 13108-1 and PD 6691 utilising aggregate to BS EN 13043 and PD 6682-2	25mm (AC 6 dense surf 100/150 des)	N/A	N/A	⁽⁸⁾
	Hot rolled asphalt to BS EN 13108-4 and PD 6691 utilising aggregate to BS EN 13043 and PD 6682-2	N/A	N/A	N/A	N/A
	Stone mastic asphalt to BS EN 13108-5 and PD 6691 utilising aggregate to BS EN 13043 and PD 6682-2	25mm (SMA 6 surf 40/60)	N/A	N/A	N/A
	Concrete designation (BS 8500-2:2015+A1:2019 table 6)	N/A	100 grade PAV1	N/A	N/A
Bedding course	Sharp sand to BS 7533-3 category II of annex D	N/A	N/A	50mm	N/A
Pavers	Block pavers to BS EN 1338 of Class 2 weathering resistance and Class 3 abrasion, as well as being of low potential for slip (Ref: Table NA.2 of BS EN 1338) ⁽⁷⁾	N/A	N/A	50mm	N/A

Notes

- 1 In the first column, European harmonised names for the pavement layers are with the old UK designations included in brackets.
- 2 Where a capping layer is specified, sub-base thickness can be reduced. Pavement Design CD 225 Revision 1 gives guidance on capping and sub-base thickness design based on CBR values with and without a capping layer.
- 3 For the minimum thickness of the sub-base for different CBR values, refer to Table 3.
- 4 Bond coat in accordance with BS 594987 should be applied to ensure effective bonding of the asphalt layers.
- 5 Bituminous mixtures/asphalt can be used as a partial replacement of a full thickness granular sub-base type 1 material.
- 6 If the binder course is subjected to an extensive period of trafficking before the surface course is applied, a recipe mixture containing a higher bitumen content will be more durable/resistant to fretting/ravelling under traffic.
- 7 Where laid to either a 90 or 45 degree herringbone pattern, the edge perimeter should be laid with one single row of stretcher bond set parallel to the edge restraint. Where block pavers are laid abutting drainage channels, gully grates, etc the upper surface of the block pavers should be set 3-6mm above the grating. Manufacturer's declared value markings W3 and S4 are acceptable. Where W3 is 1.0 kg/m² or less and S4 is 45 or more based on 'C scale unit' (for abrasion, class A2 = maximum result is 23mm, class A1 = no performance determined).
- 8 A 38mm thickness of graded 15/20mm unbound aggregate to BS EN 13242 (gravel), well rolled and compacted, should be used.
- 9 Reference to clauses are in relation to the relevant European and/or British Standards.
- 10 Asphalt contractors should be certified in accordance with the National Highway Sector Schemes for Quality Management in Highway Works - Scheme 16.

Minimum sub-base thickness

The thickness of any required capping layer and the sub-base should be determined after investigations and on-site tests have been carried out, with consideration to the:

- CBR value
- frost susceptibility of the sub-grade; where susceptible to frost, a suitable capping layer should be included below the sub-base to a suitable depth to ensure that the construction will not be affected by frost heave
- granular sub-bases should be tested and certified as being non-frost susceptible and non-plastic.

Table 3: Minimum sub-base thickness for paved areas

CBR values	Minimum thickness (mm) of sub-base ⁽¹⁾ (consolidated in accordance with MCHW Volume 1 clause 801, table 8/4)
Less than 2%	Subgrade requires improvement ⁽²⁾
2-3%	325
3-5%	250
5-7%	150
7-20%	100

Notes

- 1 Minimum thickness of sub-base may be considered for reduction when using proprietary geogrid, provided they can be adequately justified and designed by an Engineer in accordance with Technical requirement R5.
- 2 Specialist advice should be sought to improve the subgrade.

House paths and patios

The following construction will be generally acceptable for house paths and patios:

- the sub-base comprising of a 100mm thickness of clean, non-frost susceptible well consolidated crushed rock, hardcore (maximum size 50mm), slag or concrete, the surface of which is bladed with 25mm of sand
- paving slabs fully bedded in 25mm 1:4 cement:sand mortar or a suitable alternative.

Concrete paths and patios should be not less than 75mm thick and have a tamped or textured finish. The concrete mix should be suitable to give a durable and frost resistant surface, as described in Chapter 3.1 'Concrete and its reinforcement'. Movement joints, not less than 10mm wide, should be provided across the full width of the path at not more than 4m centres. A movement joint is not required at the abutment with a wall unless the opposite edge of the concrete is also restrained.

10.2.7 Materials

Materials shall be suitable for their intended use. Concrete shall be of a mix design which will achieve sufficient strength for its purpose and be sufficiently durable to remain unaffected by chemical or frost action.

Sub-base material should be type 1 to clause 803 Table 8/2, MCHW Volume 1 SHW Series 800.

Hot rolled and mastic asphalts and macadam should comply with relevant standards, including:

BS EN 13108-1	'Bituminous mixtures. Material specifications. Asphalt Concrete'
BS EN 13108-4	'Bituminous mixtures. Material specifications. Hot Rolled Asphalt'
BS EN 13108-5	'Bituminous mixtures. Material specifications. Stone Mastic Asphalt'
PD 6691	'Guidance on the use of BS EN 13108'
BS 594987	'Asphalt for roads and other paved areas'

Aggregates used in asphalt and macadam mixtures and unbound aggregate (graded 15/20mm gravel) for surfacing should comply with relevant standards, including:

BS EN 13043	'Aggregates for bituminous mixtures and surface treatments for roads, airfields and other trafficked areas'
PD 6682-2	'Guidance on the use of BS EN 13043'
BS EN 13242	'Aggregates for unbound and hydraulically bound materials'
PD 6682-6	'Guidance on the use of BS EN 13242'

Blocks, slabs, pavers, edgings, etc should comply with relevant standards, including:

BS EN 771	'Specification for masonry units'
BS EN 1344	'Clay pavers. Requirements and test methods'
BS EN 1339	'Concrete paving flags. Requirements and test methods'
BS 7533	'Pavements constructed with clay, natural stone or concrete pavers'

Topsoil and subsoil should be of a quality that will not present a hazard to users of the garden area. BS 3882 (Topsoil), BS 8601 (Subsoil) and the Contaminated Land Exposure Assessment (CLEA) guidelines provide advice on determining the suitability of topsoil and subsoil.

10.2.8 Garden areas within 3m of the home

In order to provide for adequate access to and utility immediately around the home areas up to 3m from the habitable parts of the home shall not be waterlogged.

Waterlogging of garden areas within 3m of the habitable parts of the home should be prevented by appropriate soil selection and management, and if necessary, by drainage or other suitable means.

10.2.9 Garden areas

Garden areas within 20m of habitable accommodation shall be adequately prepared, stable and provided with reasonable access.

The stability of new or existing slopes in garden areas should be determined by an engineer in accordance with Technical Requirement R5. Alternatively, the following maximum gradients should apply:

- unsupported granular soil should be 5° less than its natural angle of repose
- unsupported cohesive soil should not exceed 9° (1:6).

Garden areas should have:

- old foundations, concrete bases and similar obstructions removed from within 450mm of the finished ground surface
- appropriate action, undertaken to restore physical condition (eg soil structure) and drainage characteristics of the topsoil and subsoil that has been compacted during construction. This should include subsoil decompaction, such as rotavating, to a minimum depth of 300mm and topsoil cultivation to the full depth of compaction. Further guidance is provided in BS 3882 on the depths, handling, management and preparation of topsoil and subsoil for landscaping
- ground disturbed during construction re-graded to conform to the general shape of the adjacent ground
- a minimum thickness of 100mm topsoil provided
- topsoil should be suitable for general landscape purposes and should also not contain contaminants which may present a hazard to the occupants
- topsoil that is disturbed or compacted after placement should be fully reinstated before planting, turfing or seeding.

Subsoil should not be placed over topsoil. Construction rubbish and debris should be removed from the garden and other areas around the home before topsoiling, and before or after planting, turfing or seeding.

Access is not required to small isolated garden areas, such as narrow strips of land at the top or bottom of retaining walls, but should be provided to other areas where appropriate by steps or other suitable means.

10.2.10 External decking

Also see: Chapter 3.3

Patios and decking shall be suitable for their purpose.

Timber decking, including support, should be naturally durable or treated with preservative to Use Class 4 classification.

Decking that is more than 600mm above ground level should be:

- in accordance with guidance published by the Timber Decking and Cladding Association (TDCA), or
- designed by an engineer in accordance with Technical Requirement R5.

Decking from other materials other than timber including wood composite materials and their support made from the same or similar materials, should be suitably durable and have the following:

- a satisfactory assessment by an independent technical approvals authority acceptable to NHBC and
- designed by an engineer in accordance with Technical Requirement R5.

10.2.11 Landscaping

Planting shall be completed in a manner appropriate for the site conditions and layout. Possible future damage to the home caused by planting shall be minimised.

Where trees or shrubs have been removed, are to be retained or are to be planted by the builder, precautions should be taken to reduce the risk of future damage to homes and services in accordance with Chapter 4.2 'Building near trees'.



Technical Disclaimer

The NHBC Standards are produced by NHBC as guidance solely for our builder customers as to how to interpret the technical requirements in relation to the warranty cover provided by NHBC under its Buildmark, Buildmark Choice, Buildmark Link, Buildmark Solo, Buildmark Connect or any similar product from time to time. It has not been created or intended for distribution or use outside of that purpose. The information contained in the NHBC Standards do not constitute advice and is not to be relied upon by any third party. Nothing in the NHBC Standards is intended to, nor should it be taken to, create any legal or contractual relationship. Any third party who chooses to rely upon the information contained in the NHBC Standards shall do so entirely at their own risk and NHBC accepts no duty of care or liability, however caused, in connection with its use or reliance by any third party.



Standards

2024

NHBC, NHBC House, Davy Avenue, Knowlhill, Milton Keynes, Bucks MK5 8FP

National House-Building Council (NHBC) is authorised by the Prudential Regulation Authority and regulated by the Financial Conduct Authority and the Prudential Regulation Authority in respect of carrying on its insurance business and its insurance distribution activities.

NHBC is registered in England and Wales under company number 00320784. NHBC's registered address is NHBC House, Davy Avenue, Knowlhill, Milton Keynes, Bucks, MK5 8FP. Note that only certain parts of NHBC's products and services are within the scope of UK financial services regulation. For more information on our products and services, please see our website nhbc.co.uk or your NHBC product documentation.