

Concrete and its reinforcement

CHAPTER 3.1

This chapter gives guidance on meeting the Technical Requirements for concrete and its reinforcement.

3.1.1	Compliance	01
3.1.2	Provision of information	01
3.1.3	Storage of materials	01
3.1.4	Site-mixed concrete	01
3.1.5	Ready-mixed concrete	03
3.1.6	Concrete specification	03
3.1.7	Admixtures	06
3.1.8	Special types of concrete	07
3.1.9	Design of reinforced concrete	07
3.1.10	Installation of reinforcement	08
3.1.11	Blinding concrete	09
3.1.12	Formwork	09
3.1.13	Before concreting	09
3.1.14	Casting	09
3.1.15	Curing	10
3.1.16	Testing	10
3.1.17	Glossary	11



Introduction

Concrete design and specification should comply with the relevant British Standards. Mix design should take account of strength and durability, and follow recognised standards and practices. Alternatively, mixes in accordance with the guidance in this chapter will be acceptable. This applies to plain and reinforced concrete, whether precast or in-situ.

3.1.1 Compliance

Also see: Chapter 2.1, BS 8500 and BS EN 206

Concrete and its reinforcement shall comply with the Technical Requirements.

Concrete and its reinforcement that complies with the guidance in this chapter, which covers plain and reinforced concrete, precast or in-situ, will generally be acceptable.

Mix design should take account of strength and durability, and comply with the relevant British Standards.

3.1.2 Provision of information

Designs and specifications shall be produced in a clearly understandable format, include all relevant information and be distributed to appropriate personnel.

Design and specification information should be issued to site supervisors, relevant specialist subcontractors and suppliers, and include the following information:

Ground aggressivity	<ul style="list-style-type: none"> ■ Design sulfate class (DS class). 	<ul style="list-style-type: none"> ■ Aggressive chemical environment for concrete class (ACEC Class).
Strength and durability	<ul style="list-style-type: none"> ■ Strength. ■ Maximum free water/cement ratio and/or minimum cement content. ■ Consistence class (e.g. slump). 	<ul style="list-style-type: none"> ■ Air content (where required). ■ Aggregate size. ■ Colour.
Mix design and additional protective measures (APM)	<ul style="list-style-type: none"> ■ Specification of mix designs (concrete strength class). 	<ul style="list-style-type: none"> ■ Details of any Additional Protective Measures.
Reinforcement and movement joints	<ul style="list-style-type: none"> ■ Cover to reinforcement. ■ Reinforcement, plans, sections and bending schedules. ■ Reinforcement details at supporting edges. ■ Camber in beams and slabs, where appropriate. 	<ul style="list-style-type: none"> ■ Reinforcement around openings. ■ Drawings and bending schedules should be prepared in accordance with BS 8666. ■ Movement joints.
Formwork	<ul style="list-style-type: none"> ■ Formwork materials and features. ■ Joints. 	<ul style="list-style-type: none"> ■ Mould release agents. ■ Holes for services.
Finishing treatments	<ul style="list-style-type: none"> ■ Concrete to be left untouched or with minimum finishing may require detailed formwork drawings indicating the position and detail of joints between shutters, corners and other critical junctions. 	
Testing	<ul style="list-style-type: none"> ■ Number and frequency of samples to be taken. ■ Test laboratory details. 	<ul style="list-style-type: none"> ■ Recording of results.
Curing and protection	<ul style="list-style-type: none"> ■ Requirements for curing and striking formwork. 	<ul style="list-style-type: none"> ■ Minimum period for striking/removal of formwork, curing and protection.

3.1.3 Storage of materials

Also see: Chapter 3.2

Materials shall be properly stored to avoid impairing the performance of the finished concrete.

Where materials need to be stored, the following precautions should be taken:

- Follow manufacturer's recommendations on maximum storage time.
- Store cement in a dry place and keep each type separate.
- Store different sizes of aggregate in separate bays.
- Keep sand and aggregate clean and dry (allowance should be made in the concrete batching for moisture in the sand and aggregate).

3.1.4 Site-mixed concrete

Site-mixed concrete shall be designed and mixed to ensure sufficient strength and durability.

Concrete should be mixed using an appropriate method to achieve the required strength and durability. Except for very small quantities, a mechanical mixer should be used. Where hand mixing, add an extra 10% of cement to the quantities shown in Tables 2 and 3.

Table 1: Guidance for site-mixed concrete

Material	Guidance		
Cement or cementitious material	<ul style="list-style-type: none"> ■ BS 8500-2 including Annex A. 		
Air-entraining admixtures	<ul style="list-style-type: none"> ■ Should not be used in standardised prescribed concrete mixes. 		
Admixtures, other than air-entraining admixtures	<ul style="list-style-type: none"> ■ BS EN 934-2. 		
Water	<ul style="list-style-type: none"> ■ Mains supply water, or in accordance with BS EN 1008. 		
Aggregates	<table style="width: 100%; border: none;"> <tr> <td style="width: 50%; border: none; vertical-align: top;"> <ul style="list-style-type: none"> ■ Compliant with BS EN 12620 'Aggregates for concrete'. ■ Mixed, and precautions taken, as described in BRE Digest 357. ■ Fine and/or of coarse proportions mixed as specified. ■ Proportioned to ensure a reasonable consistency, when supplied as a mixture. </td> <td style="width: 50%; border: none; vertical-align: top;"> <ul style="list-style-type: none"> ■ Checked and precautions taken when shrinkable aggregates, aggregates susceptible to alkali attack or excessive moisture movement, or unfamiliar materials are used. ■ Within the limits of the aggregate carbon range (ACR), when subject to aggressive sulfate ground conditions. ■ Assessed in accordance with Technical Requirement R3 where materials are recovered or proprietary. </td> </tr> </table>	<ul style="list-style-type: none"> ■ Compliant with BS EN 12620 'Aggregates for concrete'. ■ Mixed, and precautions taken, as described in BRE Digest 357. ■ Fine and/or of coarse proportions mixed as specified. ■ Proportioned to ensure a reasonable consistency, when supplied as a mixture. 	<ul style="list-style-type: none"> ■ Checked and precautions taken when shrinkable aggregates, aggregates susceptible to alkali attack or excessive moisture movement, or unfamiliar materials are used. ■ Within the limits of the aggregate carbon range (ACR), when subject to aggressive sulfate ground conditions. ■ Assessed in accordance with Technical Requirement R3 where materials are recovered or proprietary.
<ul style="list-style-type: none"> ■ Compliant with BS EN 12620 'Aggregates for concrete'. ■ Mixed, and precautions taken, as described in BRE Digest 357. ■ Fine and/or of coarse proportions mixed as specified. ■ Proportioned to ensure a reasonable consistency, when supplied as a mixture. 	<ul style="list-style-type: none"> ■ Checked and precautions taken when shrinkable aggregates, aggregates susceptible to alkali attack or excessive moisture movement, or unfamiliar materials are used. ■ Within the limits of the aggregate carbon range (ACR), when subject to aggressive sulfate ground conditions. ■ Assessed in accordance with Technical Requirement R3 where materials are recovered or proprietary. 		

The information below applies to cement strength class 32.5 and 20mm maximum aggregate size. Where cement strength class 42.5 or higher is used, the cement weight should be decreased by 10%.

Table 2: Mix proportions by weight

Standardised prescribed mix	Consistence class (slump in mm)	Cement (kg)	Fine aggregate (kg)	Coarse aggregate (kg)
ST1	S1 (10-40)	230	770	1155
ST2	S2 (50-90)	265	760	1135
ST2	S3 (100-150)	285	735	1105
ST2	S4 (160-210)	300	815	990
ST3	S2 (50-90)	295	745	1120
ST4	S2 (50-90)	330	735*	1100
ST5	S2 (50-90)	375	720*	1080

* Fine aggregate grading to be grades CP or MP only of BS EN 12620.

Table 3: Mix proportions by volume using a maximum 20mm aggregate size

Cement strength class	Standardised prescribed mix	Consistence class (slump in mm)	Number of (25 kg) bags of cement	Fine aggregate (litres)	Coarse aggregate (litres)
32.5	ST1	S1 (10-40)	1	60	85
	ST2	S2 (50-90)	1	50	75
	ST2	S3 (100-150)	1	45	70
	ST2	S4 (160-210)	1	50	60
	ST3	S2 (50-90)	1	45	65
42.5 or higher	ST1	S1 (10-40)	1	65	95
	ST2	S2 (50-90)	1	55	80
	ST2	S3 (100-150)	1	50	75
	ST2	S4 (160-210)	1	55	65
	ST3	S2 (50-90)	1	50	75

3.1.5 Ready-mixed concrete

Ready-mixed concrete shall be from a supplier operating under a quality control system acceptable to NHBC and be of sufficient strength and durability.

Ready-mixed concrete is acceptable from suppliers who operate under a full quality control scheme such as:

- the Quality Scheme for Ready-Mixed Concrete (QSRMC), or
- the BSI Kitemark scheme.

Other suppliers may be suitable if they operate to an equivalent quality standard acceptable to NHBC.

Ready-mixed concrete should be ordered to a detailed specification conforming to BS 8500 and BS EN 206.

When designated mixes are used, the ready-mix supplier will only require the mix designation, and consistence class. (see 3.1.6 Table 4)

Delivery information should be checked to ensure that the concrete meets the requirements given in the design.

3.1.6 Concrete specification

Also see: BRE Digest 357, BRE Special Digest 1, BS 8500, BS 8500-1 and BS EN 206

Concrete shall be specified correctly to ensure adequate strength and durability. Issues to be taken into account include:

- | | |
|----------------------------------------------------|--------------------------------------|
| a) concrete in non-hazardous conditions | e) effects of chlorides |
| b) exposure to climatic and atmospheric conditions | f) effects of alkali-silica reaction |
| c) exposure to aggressive ground conditions | g) aggregates. |
| d) exposure to sulfates and acids in groundwater | |

Concrete mixes should be suitable for particular end uses and specified in accordance with BS 8500-1 as either:

- designated mix, which is supplied ready mixed, or
- standardised prescribed mix for site mixing.

Designated mixes should conform to Table 6 of BS 8500-2. Standardised prescribed mixes should conform to Tables 2 and 3 in this chapter.

Mixes should also be designed for the expected conditions of the geographical location of the site and the location of the concrete element in the structure. Higher grade concrete has greater resistance to chemical and mechanical damage and should be specified accordingly.

In addition to the issues in this section, durability is reliant on:

- correct control of the water:cement ratio
- good curing.
- full compaction of the placed concrete

Concrete in non-hazardous conditions

Table 4: Minimum specifications for general purpose concrete mixes

Location and use	BS 8500 and BS EN 206		
	Ready-mixed concrete (designated mix)	Site-mixed concrete (standardised prescribed mix)	Consistence class
Substructure and ground floors <ul style="list-style-type: none"> ■ Rough blinding (non-structural). ■ Infill. ■ Unreinforced oversite concrete below timber floors. 	GEN1	ST2	S3
<ul style="list-style-type: none"> ■ Structural blinding and over break. ■ Strip foundations. ■ Trench fill. ■ Other mass concrete foundations. ■ Fill to wall cavity. ■ Solid filling under steps. 	GEN1	ST2	S3/S4 ⁽¹⁾
<ul style="list-style-type: none"> ■ House floors not designed as suspended and not reinforced: <ul style="list-style-type: none"> – Permanent finish to be added, e.g. screed or floating floor. – No permanent finish to be added, e.g. carpet. 	GEN1 GEN2	ST2 ST3	S2 S2

Table 4 (continued): Minimum specifications for general purpose concrete mixes

Location and use	BS 8500 and BS EN 206		
	Ready-mixed concrete (designated mix)	Site-mixed concrete (standardised prescribed mix)	Consistence class
■ Garage floors not designed as suspended and not reinforced.	GEN3	ST4	S2
■ House and garage ground floor slabs: – Fully or nominally reinforced, either ground bearing, suspended or over sub-floor voids.	RC35	ST5 ⁽²⁾	S2
Superstructure			
■ General reinforced concrete exposure class ⁽³⁾ to BS8500-1: – Nominal cover to reinforcement of 35mm (which is the minimum cover of 25mm plus an allowance in design for deviation of 10mm). – XC1 (dry) and XC2 (wet, rarely dry). – XC3 (moderate humidity), XC4 (cyclic wet and dry) and XF1 (freeze/thaw attack and no de-icing agent). – Nominal cover to reinforcement of 40mm (which is the minimum cover of 30mm plus an allowance in design for deviation of 10mm). – Any exposure class (XC1-4 and XF1).	RC30 RC40 RC35	⁽⁴⁾ – ⁽⁵⁾	S2 S2 S2
In-situ external concrete			
■ Drives and paths.	PAV1	ST5 ⁽⁶⁾	S2
■ Foundations for precast concrete paving slabs.	GEN1	ST1	S1

Notes

- Consistence class S3 should be used for strip foundation concrete and consistence class S4 should be used for trench fill foundation concrete.
- ST4 mix for house and garage floors may only be used in conjunction with Chapter 5.2 'Suspended ground floors'. In all other cases, the designated mix should be used.
- Exposure classes (XC1-4 and XF1) are defined in BS 8500-1 Table A.1.
- In this situation, ST4 mix may be used only for small quantities of concrete. In all other cases, the appropriate designated mix should be used.
- In this situation, an ST5 mix may be used only for small quantities of concrete. In all other cases, the appropriate designated mix should be used.
- Not suitable in areas of severe exposure to frost attack. This is equivalent to exposure class XC4 above.

Exposure to climatic and atmospheric conditions

Any concrete mix should be designed for the conditions expected at the geographical location of the site and at the location of the element in the structure.

Table 5: Exposure classes and examples of where they may occur, based on Table 1 of BS EN 206

Exposure class	Environment	Exposure conditions
XC1	Dry or permanently wet	Concrete inside buildings with low air humidity. Concrete permanently submerged in water.
XC2	Wet, rarely dry	Concrete surfaces subject to long-term water contact. Many foundations.
XC3	Moderate humidity	Concrete inside buildings with moderate or high air humidity. External concrete sheltered from rain.
XC4	Cyclic wet and dry	Concrete surfaces subject to water contact, not within exposure class XC2.
XF1	Moderate water saturation, without de-icing agent	Vertical concrete surfaces exposed to rain and freezing.

Concrete in aggressive ground

Mixes should conform to BS 8500. The information in this section describes minimum specifications for lower range 'chemical aggressiveness'. Specialist advice should be sought for more aggressive conditions.

Table 6: Aggressive chemical environment for concrete (ACEC) site classification⁽¹⁾ and applies to concrete exposed to ground with a pH value greater than 2.5

Sulfate and magnesium				Natural soil		Brownfield ⁽³⁾				ACEC class for site
Design sulfate class for site	2:1 water/soil extract	Ground water	Total potential sulfate ⁽²⁾	Static water	Mobile water	Static water		Mobile water		
1	2	3	4	5	6	7	8	9	10	11
	SO ₄	Mg	SO ₄	Mg	SO ₄	pH	pH	pH ⁽⁵⁾	pH ⁽⁵⁾	
	mg/l	mg/l	mg/l	mg/l	%					
DS-1	<500	All Mg values	<400	All Mg values	<0.24	>2.5		>2.5		AC-1s
							>5.5 ⁽⁶⁾		>6.5	AC-1
							2.5 -5.5		5.5-6.5	AC-2z
									4.5-5.5	AC-3z
									2.5-4.5	AC-4z
DS-2	500-1500	All Mg values	400-1400	All Mg values	0.24-0.6	>3.5		>5.5		AC-1s
							>5.5		>6.5	AC-2
						2.5-3.5		2.5-5.5		AC-2s
							2.5-5.5		5.5-6.5	AC-3z
									4.5-5.5	AC-4z
									<4.5	AC-5z

Notes

- For concrete quality and APM for ACEC classes above AC-2z, follow specialist advice. For the full list of ACEC classes, refer to Table A.2 of BS 8500-1 or BRE Special Digest Part C Table C1 for natural ground locations, and Table C2 for brownfield locations.
- Applies only to sites where concrete will be exposed to sulfate ions (SO₄), which may result from the oxidation of sulfides such as pyrite, following ground disturbance.
- Applies to locations on sites that comprise either undisturbed ground that is in its natural state or clean fill derived from such ground.
- 'Brownfield' is defined as sites which may contain chemical residues remaining from previous industrial use or from imported wastes.
- An additional account is taken of hydrochloric and nitric acids by adjustment to sulfate content.
- For flowing water that is potentially aggressive to concrete owing to high purity or an aggressive carbon dioxide level greater than 15mg/l, increase the ACEC class to AC-2z.

Explanation of suffix symbols to ACEC class number:

- Suffix 's' indicates that, as the water has been classified as static, no additional protective measures are generally necessary.
- Concrete placed in ACEC classes which include the suffix 'z' have primarily to resist acid conditions and may be made with any of the cements or combinations listed in Table D2 of BRE Special Digest 1.

This table is based on Tables C1 and C2 of BRE Special Digest 1.

The information in Table 7 provides guidance on selecting mixes for concrete elements in aggressive ground.

Table 7: Design guide for concrete elements in the ground

Concrete element	ACEC class ⁽¹⁾	Designated mix
Strip or trench fill foundation, raft foundation, pile ⁽³⁾ and ground beams.	AC-1, C1s	As Table 4
	AC-2, C2s	FND2 ⁽²⁾
	AC-2z	FND2z ⁽²⁾

Notes

- For all other ACEC classes, follow specialist advice.
- Portland limestone cement may only be used where the design sulfate class (see Table 5) of the site does not exceed DS-1.
- Applies to cast-in-situ piles only – for other types of pile refer to BRE Special Digest 1 or follow specialist advice.

Exposure to sulfates and acids in groundwater

Sulfates, chemicals and high acidity can cause expansion, cracking and damage to concrete. Where ground water is highly mobile, or where concrete is at risk from chemical attack, the level of sulfate and other chemicals should be determined according to the ACEC class (aggressive chemical environment for concrete class) and BRE Special Digest 1.

For higher ACEC classes, specialist advice should determine the design chemical class (DC class) and appropriate additional protective measures (APM) where required. Table A.7 of BS 8500-1 should be used to select the mix specification.

For lower ACEC classes (AC-1, AC-1s, AC-2, AC-2s and AC-2z), information in Tables 6 and 7 should be used to select the mix specification.

Effects of chlorides

Chlorides, which are contained in all concrete materials, increase the risk of corrosion in metal and can reduce the chemical resistance of concrete, therefore chloride content of fresh concrete should be limited in accordance with BS EN 206 Table 15.

Cured concrete can be damaged by chlorides in the ground, sea spray, or products used for de-icing highways, and specialist guidance should be followed.

Effects of alkali-silica reaction

Alkalis can cause expansion, cracking and damage to concrete. Damage can occur when all the following conditions are present:

- a source of alkali
- a high moisture content
- where the aggregate is alkali reactive.

Alkali content calculated in accordance with BRE Digest 330 or Concrete Society Technical Report 30 should not exceed 3kg/m³. Where unfamiliar aggregate materials are used, special precautions may be required.

Standardised prescribed mixes should conform to BS 8500.

Aggregates

Aggregates should be of a grade which ensures adequate durability of the concrete. Certain types of aggregate are shrinkable and require special precautions in mixing. Certain types of aggregate may be susceptible to alkali attack or excessive moisture movement.

Proprietary and recovered aggregates should only be specified where they have been assessed in accordance with Technical Requirement R3.

3.1.7 Admixtures

Admixtures shall only be used to enhance the performance and durability of concrete.

Issues that should be taken into account include:

- improved workability
- waterproofing
- foaming agents
- accelerated strength
- retardation
- chlorides.

Admixtures should comply with BS EN 934-2 Admixtures for concrete mortar and grout - Concrete admixtures - Definitions, requirements, conformity, marking and labelling, should be used in accordance with BS EN 206 and should be:

- specified only with full knowledge of their limitations and effects
- used only where permitted in the specification
- tested in trial mixes, where necessary
- added to the mix water to ensure complete dispersal
- dosed correctly
- used strictly in accordance with the manufacturer's instructions.

Accelerators produce early setting of the concrete, and plasticisers can improve concrete cohesion and the bond with reinforcement.

Air-entraining agents should not be used as an anti-freeze for fresh concrete. Though they can increase the frost resistance of cured concrete and are recommended for paths, drives and pavements which are likely to be exposed to freezing conditions.

Retarding agents can increase the risk of frost damage.

Admixtures containing chlorides can cause metal corrosion and should not be used in reinforced concrete.

3.1.8 Special types of concrete

Special types of concrete shall be appropriate for their use.

Proprietary concrete, no-fines or lightweight concrete should be of a quality and density appropriate for the conditions and use. Where no-fines concrete is used, a render, cover coat or cladding should be applied to the finished structure.

Proprietary methods of reinforcement, e.g. glass fibre, should be assessed in accordance with Technical Requirement R3.

Structural design should be in accordance with Technical Requirement R5 and the mix properly detailed.

3.1.9 Design of reinforced concrete

Also see: BS EN 1992-1-2

Reinforced concrete shall be suitable for its intended use. Issues to take into account include:

- | | |
|------------------------------------------|--------------------|
| a) compliance with appropriate standards | d) fire resistance |
| b) end restraint | e) carbonation. |
| c) concrete cover | |

Reinforced concrete should be designed by an engineer in accordance with Technical Requirement R5. BS 8103-1 can be used for the design of suspended ground floors in homes and garages.

Compliance with appropriate standards

The steel specification should indicate the steel type, grade and size. Drawings and bending schedules should be prepared in accordance with BS 8666 and include all necessary dimensions for completion of the sitework. Reinforcement should comply with the standards listed below.

BS EN 1992-1	'Design of concrete structures'.
BS 4449	'Steel for the reinforcement of concrete'. Specification
BS 4482	'Steel wire for the reinforcement of concrete products'. Specification
BS 4483	'Steel fabric for the reinforcement of concrete'. Specification
BS 6744	'Stainless steel bars. Reinforcement of concrete'. Requirements and test methods
BS 8103-1	'Structural design of low-rise buildings'. Code of practice for stability, site investigation, foundations, precast concrete floors and ground floor slabs for housing

End restraint

Where the ends of slabs are cast monolithically with concrete members, surface cracking may develop over the supports. Reinforcement should therefore be provided in accordance with BS EN 1992-1-1.

Concrete cover

There should be adequate cover to the reinforcement, especially where it is exposed or in contact with the ground. Cover should be adequate for all reinforcement, including main bars and stirrups. No ties or clips should protrude into the concrete cover.

For concrete not designed by an engineer, the minimum cover for reinforcement should be in accordance with Table 8.

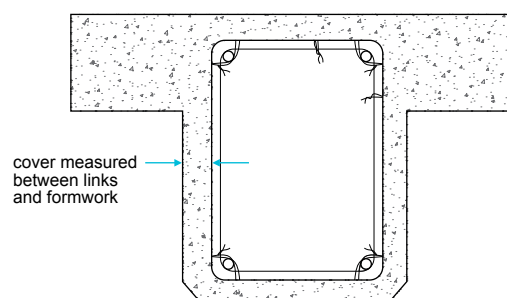

Table 8: Minimum cover for reinforcement for concrete not designed by an engineer

Position of the concrete	Minimum cover (mm)
In contact with the ground.	75
External conditions.	50
Cast against a DPM on sand blinding.	40
Against adequate blinding concrete.	40
Protected or internal conditions.	25

Fire resistance

Concrete cover to reinforcement should be adequate to resist fire. Requirements for fire resistance are given in BS EN 1992-1-2. Cover required by BS EN 1992-1-1 will normally provide up to one hour of fire resistance for columns, simply supported beams and floors.

Carbonation

Carbonation reduces the corrosion protection of the reinforcement by increasing porosity and decreasing alkalinity. Such corrosion can be reduced by providing as much concrete cover as possible, and by ensuring that the wet concrete is of good quality and properly compacted to reduce the rate of carbonation.

3.1.10 Installation of reinforcement

Also see: Chapter 5.2

Reinforcement shall be installed in accordance with the design. Issues to take into account include:

- a) shape, placing and condition of reinforcement bars
- b) lapping bars and mesh
- c) support for reinforcement.

Shape, placing and condition of reinforcement bars

Main reinforcing bars	Should be parallel to the span, or as detailed in the design.
Slab reinforcement	Should be located near the bottom of the slab, with the main reinforcing bars placed first and the secondary bars on top.
Beams	Should have the main reinforcing bars placed inside the links.

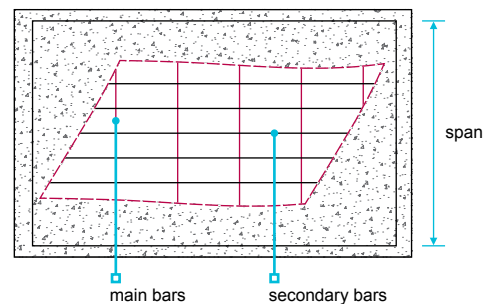

Reinforcement should be:

- bent using appropriate equipment and placed in accordance with the design
- clean and free from loose rust and contaminants, especially shutter-releasing agents and oil.

Lapping bars and mesh

Reinforcing bars or mesh should be lapped according to type and size as indicated by the designer to ensure that loads are fully transferred across the lap. Any additional laps require the designer's approval.

Support for reinforcement

Spacers should be either concrete blocks (no more than 50 x 50mm) or ready-made of steel or plastic. Supports should be placed no more than one metre apart, or closer where necessary.

Spacers for parallel bars should be staggered to avoid creating a plane of weakness in the concrete. Supports for top steel should be chairs, or other proprietary products.

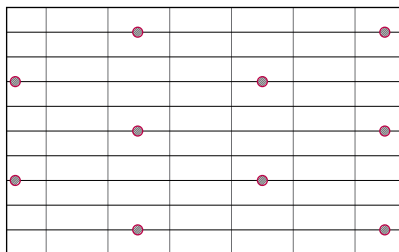

spacers staggered to avoid planes of weakness

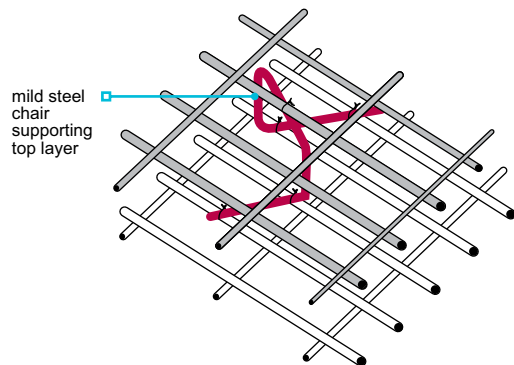

3.1.1 Blinding concrete

Blinding concrete shall be used where required to aid construction.

Blinding concrete should only be used:

- to protect the bottom of the trench/excavation where there is a delay in pouring structural concrete
- where the foundation has been slightly overdug
- to provide sufficient support to ensure cover to reinforcement is maintained, or
- where localised soft spots have been removed.

3.1.2 Formwork

Formwork shall be structurally adequate and constructed in a workmanlike manner.

Formwork should be accurately set out in relation to relevant reference lines and benchmarks. Accuracy is essential to ensure that the correct cover to the reinforcement is maintained.

Formwork and its supports should be rigid enough to maintain the correct position and to withstand extra loads and accidental knocks likely to occur during placement and compacting. Wedges, inserts and boxes should be firmly secured to avoid displacement during vibration.

For concrete which is to be left untreated, or with minimum finishing, formwork joints should be tight to avoid grout loss and ragged edges. Joints between shutters should be constructed for easy stripping. Any holes for bolts or spacers should be drilled with care to avoid disfiguring or splintering the formwork surface and giving a poor finish.

Formwork should be capable of being struck without damage to the concrete. Formwork should be dismantled without shock, disturbance or damage to the concrete. Support for load-bearing elements should not be removed until the concrete has achieved sufficient strength, as detailed by the designer. Props under suspended floors or beams should be released from the centre, outwards, to avoid overloading.

3.1.3 Before concreting

Installations and final preparations shall be completed before concreting starts.

Before concreting starts:

- all services, ducts, inserts, etc. to be embedded in the concrete should be securely installed in the correct position and, where appropriate, tested
- completed reinforcement should be checked and, where necessary, approved by the designer or their representative
- formwork should be cleaned out and checked for fallen debris, especially nails and wire clippings.

3.1.4 Casting

Also see: Chapter 3.2

Concrete shall be cast so as to achieve the required design strength and durability.

The temperature of the concrete at the point of use should not be less than 5°C (41°F). Fresh concrete is susceptible to frost damage, and freezing can cause internal damage that is not immediately obvious.

Concrete should not be placed in or under water, unless it has been specially designed for that use.

Sufficient concrete should be mixed or ordered, so that it can be placed in a continuous process.

Concrete should be deposited as close as possible to its final location. Transportation on site should be as fast and efficient as possible in order to avoid segregation and to ensure full compaction of the placed concrete.

Site-mixed concrete should be placed within 30 minutes, and ready-mixed concrete within two hours, of water being added to the cement. Additional water should not be added to ready-mixed concrete unless under the supervision and approval of the supplier.

Concreting should, wherever possible, be carried out in one operation, taking account of:

- weather conditions
- available daylight
- time to allow for surface finishing.

Concrete cast in one operation (i.e. without construction joints) should always be as square in shape as possible and not greater than:

- reinforced concrete 60m²
- unreinforced concrete 16m².

Construction joints should be formed only where unavoidable and in consultation with the engineer. These should not be positioned next to a return in the foundation. Before work continues beyond the joint, shuttering used to form the joint should be removed.

Reinforced concrete should be fully compacted using poker vibration unless the design states otherwise. Poker vibration should be carried out by experienced operators to ensure complete coverage and to avoid honeycombing. Vibrating beams or hand tamping may be used to consolidate slabs up to 150mm thick, unless the design details otherwise. Excessive use of vibration can cause segregation and prevent concrete reaching an adequate strength.

3.1.15 Curing

Also see: Chapter 3.2

Concrete shall be adequately cured to achieve full design strength.

Concrete performance relies on the curing process. The design should clearly indicate where there are any special requirements for curing concrete.

Freshly poured concrete should be kept moist by covering as soon as the surface is hard enough to resist damage. This is particularly important in hot, windy or cold weather to prevent the surface drying out too rapidly, or freezing. Damp hessian, damp sharp sand or an impervious sheet (such as polyethylene) are acceptable as surface coverings. Alternatively, a curing agent can be applied to the surface.

No load should be applied to the work until the concrete has cured sufficiently. It is recommended that plain unreinforced concrete made with ordinary Portland cement is left for at least four days to cure.

It is possible to proceed with substructure masonry above strip or trench fill foundations on unreinforced ordinary Portland cement concrete at an early stage, provided that care is taken to protect the surface from damage.

Reinforced concrete or concrete containing cement replacements, such as PFA, will require a longer curing period. This will normally take seven days, during which the concrete structure should not be loaded.

Any curing agents should comply with Technical Requirement R3 and should be applied strictly in accordance with the manufacturer's instructions. Curing agents should never be used on floors which are to receive either a topping or a screed, as it could affect the future bond. Curing periods may be extended at low temperatures.

3.1.16 Testing

Testing shall be carried out to the full satisfaction of NHBC.

Testing, where required, shall be conducted to BS EN 12390 by UKAS approved laboratories. Test cubes should be prepared as requested by the engineer. These should be marked, cured and stored safely until testing.

Proof of testing, with reports, certificates and allied documentation, should be kept for reference and made available to NHBC upon request.

Ready-mixed concrete supplier should prepare test cubes in accordance with quality assurance procedures.

3.1.17 Glossary

Aggressive chemical environment for concrete classification (ACEC class)	A system for the classification of aggressive ground conditions that are derived from design sulfate class. It takes into account the site (natural or brownfield) and the mobility and pH of ground water. Brownfield, 'mobile' water and low pH (acidic) conditions may have adverse effects on buried concrete and hence result in a more severe ACEC class.
Additional protective measures (APM)	These are defined as the extra measures that could be taken to protect concrete where the basic concrete specification might not give adequate resistance to chemical attack.
Design chemical class (DC class)	This defines the qualities of concrete that are required to resist chemical attack. The DC class is derived from the ACEC class of the ground and other factors, including the type of concrete element and its required structural performance.
Design sulfate class (DS class)	A site classification based on the determined sulfate (including potential sulfate) contents of the ground and/or ground water. It is also dependent on the type of site, presence or absence of magnesium ions, pyrite, and for pH less than 5.5, chloride and nitrate ions. Five levels of classification are given that are equivalent to those given in BRE Digest 363 (now superseded).
Enhanced concrete quality	An incremental step in concrete quality that could be used as an Additional Protective Measure (APM). Each increment in concrete quality is counted as an extra APM.
Mobile ground water	Sites where water is free to flow into an excavation to give a standing water level are affected by mobile ground water. The threshold ground permeability is greater than 10^{-6} m/s (i.e. 86mm/day).
Static ground water	The sites where the free flow of water is confined due to either permanently dry conditions or the soil is relatively impermeable (of permeability less than 10^{-6} m/s).
Total potential sulfate (TPS)	The total potential sulfate content is the result of the combination of sulfates already present in the ground and that which may be added due to the oxidation of pyrite in the ground.

Cold weather working

CHAPTER 3.2

This chapter gives guidance on meeting the Technical Requirements for cold weather working.

3.2.1	Compliance	01
3.2.2	External conditions	01
3.2.3	Materials	01
3.2.4	Concreting	01
3.2.5	Masonry	02
3.2.6	Rendering, plastering and screeding	02
3.2.7	Admixtures	03
3.2.8	Painting	03



3.2.1 Compliance

Also see: Chapter 2.1

Cold weather working shall comply with the Technical Requirements.

Sitework which complies with the guidance in this chapter will generally be acceptable.

3.2.2 External conditions

Also see: Meteorological Office

Allowance shall be made for cold weather conditions during construction.

Work should be planned in advance, and account taken of site and climatic conditions either by:

- stopping work, or
- taking adequate precautions.

The following conditions should be considered when scheduling work:

- Wind (this can create a cooling effect which can reduce temperatures further, i.e. affecting the curing of concrete and mortar).
- Shade (in particular high trees or adjacent buildings can block low winter sun and reduce temperatures further).
- Valleys (sites in valleys are susceptible to increased risk of frost).

Where air temperature is below, or likely to fall below, 2°C, work should not proceed unless the precautions detailed in this chapter are adopted.

A thermometer should be sited in the shade and used to indicate if temperatures are rising or falling.

3.2.3 Materials

Materials shall be adequately protected against cold weather.

Materials should:

- not be used if frozen
- be protected using appropriate covers to prevent damage by snow, ice, frost or damp.

Appropriate covers should be provided for bricks and blocks, sand, aggregates and cement, to prevent them from becoming saturated and damaged by frost.

Where it is necessary to continue building during longer periods of colder weather, heaters should be used to protect materials.

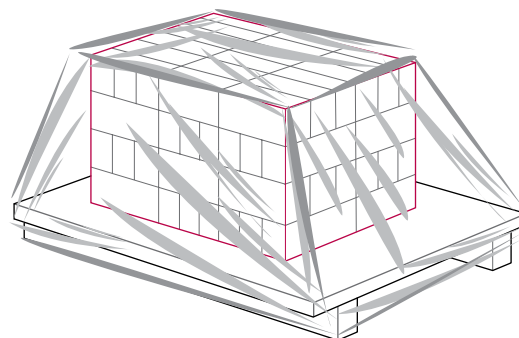

3.2.4 Concreting

Also see: BS EN 13670 Table 4 Curing class 2 and Table F1 Curing class 2

Concrete shall not be placed in cold weather unless suitable precautions are taken.

The minimum temperature of ready-mixed concrete when delivered should be 5°C, in accordance with BS EN 206.

When concreting is undertaken during colder weather, curing periods should be adjusted according to environmental conditions. Concrete should:

- be covered to maintain the temperature above freezing, and heated if necessary
- not be placed where the ground, oversite or the surfaces that will be in contact with the concrete are frozen
- be placed with caution where small quantities of fresh concrete are against a large volume of hardened concrete which is at a lower temperature.

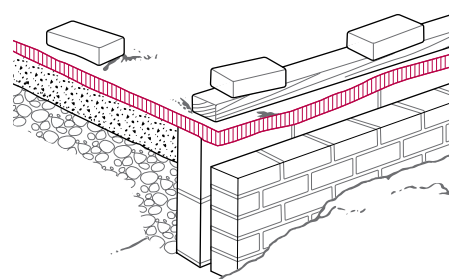

Where slight overnight frosts are expected, 50mm of insulation held down firmly at the edges should be used to help protect oversite concrete. Where very severe frosts are expected, insulation alone is inadequate and heating should be provided.

Site-mixed concrete

If the air temperature drops to 2°C, concrete work should not proceed unless:

- the ground into which the concrete is to be placed is not frozen
- the aggregate temperature is above 2°C
- the aggregate is free of frost and snow
- the water for mixing is heated, but not above 60°C (cement should not be heated)
- the cast concrete can be properly protected, taking account of the cross-sectional area and location.

In prolonged or very severe cold weather:

- covers will not stop severe frost penetrating the aggregate
- where work is to continue, it may be necessary to steam heat aggregates or to use hot air blowers below covers
- heating the mixing water cannot be relied upon to thaw frozen aggregates, and very cold aggregate can still remain frozen.

3.2.5 Masonry

Masonry shall not be laid in cold weather unless suitable precautions are taken.

When laying masonry in cold weather:

- and temperatures are below, or are likely to fall below, 2°C (temperatures should be checked throughout the day on a thermometer), masonry should not be laid unless heating is provided and newly laid masonry protected
- materials which have been damaged by frost or are frozen should not be used
- additional covers and insulation will be necessary at very low temperatures
- polyethylene covers should be used to provide protection and prevent work from becoming saturated (an air gap between the masonry and the covers will enable new masonry to cure)
- where very severe frosts are expected, heaters may be required
- protection against frost may be required for up to six days, depending on the severity of the conditions.

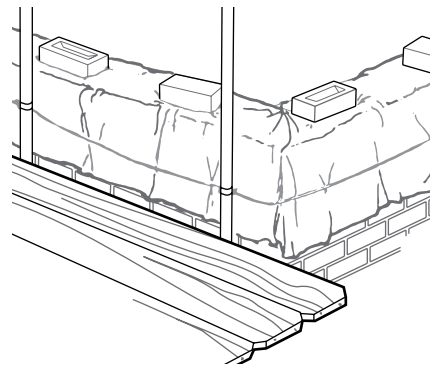

3.2.6 Rendering, plastering and screeding

Also see: Chapter 6.11

Rendering, plastering and screeding shall not be carried out in cold weather unless suitable precautions are taken.

Rendering, plastering and screeding should not be carried out if there is frost on the structure.

Where warm air heaters are used to warm the structure before screeding and plastering takes place, they should:

- keep the temperature of the structure above freezing during the curing period
- not produce water vapour (the building should be ventilated to disperse moisture)
- be placed in the room a day before plastering is to start
- be used for longer following a prolonged cold period (as ground floors and walls near to floor level may be slow to respond)
- continue heating for at least 48 hours after completion of the work but not be excessive (to avoid damage to screeds, plaster finishes and woodwork).

Render should not be applied if:

- the temperature is below, or likely to fall below, 2°C (temperatures should be checked throughout the day on a thermometer)
- backgrounds are saturated or frozen, or
- there is a possibility that new work will be subjected to frost before it has set.

3.2.7 Admixtures

Admixtures shall be used correctly and in accordance with the manufacturer's recommendations.

When using admixtures:

- accelerators may assist the mortar or concrete to set before temperatures fall (admixtures do not prevent frost damage to uncured concrete or mortar)
- plasticisers can entrain air during mixing to provide frost resistance to mature mortar and concrete
- in cold weather, retarding agents should not be used as they can increase the setting times of cement
- in cold weather, bonding agents may be ineffective
- those containing calcium chloride should be avoided.

3.2.8 Painting

Painting shall not be carried out when there is a risk of damage due to cold weather.

Paint should not be applied:

- on surfaces affected by damp, frost or condensation
- where the air temperature is below, or likely to fall below 2°C
- when condensation, snow or rain is likely to affect paintwork before it is dry.

Timber preservation (natural solid timber)

CHAPTER 3.3

This Chapter gives guidance on meeting the Technical Requirements and recommendations for the protection of natural solid timber against fungal decay when exposed to damp conditions and against insect attack.

3.3.1	Compliance	01
3.3.2	Durability	01
3.3.3	Sitework	03
3.3.4	Protection and storage	03
3.3.5	Treatment of cut surfaces	03
3.3.6	Compatibility with metal	03
3.3.7	Further information	03



Introduction

This chapter gives acceptable treatment schedules for the treatment of natural solid timber but does not cover:

- products such as plywood and wood particle boards
- the condition before the treatment
- treatment process techniques, which is the responsibility of the organisation carrying out the operation.

3.3.1 Compliance

Also see: Chapter 2.1

Timber preservative treatments and processes shall comply with the Technical Requirements and reasonably ensure that the timber is safely and satisfactorily protected against fungal decay and insect attack.

Timber preservative treatments that comply with the guidance in this chapter will generally be acceptable. Timber and external joinery should either be:

- naturally durable and resistant to insect attack, or
- treated with preservative in accordance with this chapter.

It is important that treatment of timber and joinery is carried out to appropriate standards which are both suitable and safe. Treatments in accordance with procedures set out in British Standards, Codes of Practice, or which have been satisfactorily assessed by an independent authority in accordance with Technical Requirement R3, will generally be acceptable. The specification should state the specific treatment and standard required.

All preservatives should meet the requirements of the Control of Pesticides Regulations (1986) administered by the Health and Safety Executive. The safety instructions published by the manufacturers should be followed.

3.3.2 Durability

Timber and joinery used in the construction of homes shall either have adequate natural durability or, where treatment is undertaken, receive a satisfactory preservative treatment against fungal decay and insect attack.

Timber component groups and preservative treatment required are shown in Table 1 below (based on BS 8417), which provides information to establish the appropriate type of treatment according to the particular element and conditions of use. Table 2 provides information on the timber species and durability.

Table 1: Timber component groups and preservative treatment

Component group	Examples	Use class	Desired service life	Preservative type required				Preservative treatment not required
				Copper organic ⁽¹⁾	Water-based organic ⁽¹⁾	Organic solvent or micro-emulsion ⁽¹⁾	Boron ⁽²⁾	
Internal joinery, intermediate floor joists	Architraves, internal doors, intermediate floor joists	1	60	✓	✓	✓	✓	Unless a specific request for treatment against insect attack has been made.
Roof timbers (dry)	Pitched roofs: rafters, purlins, joists, wall plates	1	60	✓	✓	✓	✓	Unless a specific request for treatment against insect attack has been made.
Roof timbers (dry) in areas with house longhorn beetle	As above	1	60	✓	✓	✓	✓	Where timber used is: <ul style="list-style-type: none"> ■ softwood – heartwood only⁽³⁾ and of durability class 1 – 3⁽⁴⁾ or ■ hardwood.
Roof timbers (risk of wetting)	Flat roofs joists, sarking, tiling battens, valley boards, timbers exposed to risk of condensation, porch posts – coated and held clear of the ground and standing water, in a free draining shoe made from suitably durable material such as galvanized or stainless steel.	2	60	✓	✓	✓	✓	Where timber used is: <ul style="list-style-type: none"> ■ heartwood only⁽³⁾ and of durability class 1 – 2⁽⁴⁾
Roof timbers (risk of wetting) in areas with house longhorn beetle	As above	2	60	✓	✓	✓	✓	Where timber used is heartwood only ⁽³⁾ and of durability class 1 – 2 ⁽⁴⁾ .

Table 1 (continued): Timber component groups and preservative treatment

Component group	Examples	Use class	Desired service life	Preservative type required				Preservative treatment not required
				Copper organic ⁽¹⁾	Water-based organic ⁽¹⁾	Organic solvent or micro-emulsion ⁽¹⁾	Boron ⁽²⁾	
External walls/ ground floors	Timber frames, ground floor joists, l-beam studwork	2	60	✓	✓	✓	✓	Where timber used is heartwood only ⁽³⁾ and of durability class 1 – 2 ⁽⁴⁾ .
Sole plates ⁽⁵⁾		2	60	✓	✓	✓	✓	Where timber used is heartwood only ⁽³⁾ and of durability class 1 – 2 ⁽⁴⁾ .
External joinery, coated (not in ground contact) ⁽⁶⁾	Window frames, door frames, doors, cladding (coated), soffits, fascias, barge boards	3	30	⁽⁷⁾	⁽⁷⁾	✓	✓	Where timber used is heartwood only ⁽³⁾ and of durability class 1 – 2 ⁽⁴⁾ .
Uncoated external timbers (not in ground contact)	Decking (where the deck is up to 600mm from ground level) ⁽⁸⁾ , cladding (uncoated)	3	15	✓	✓	✗	✗	Where timber used is heartwood only ⁽³⁾ and of durability class 1 – 2 ⁽⁴⁾ .
Timber in contact with the ground	Decking timber in ground contact (where the deck is up to 600mm from ground level) ⁽⁸⁾	4	15	✓	✗	✗	✗	Where timber used is heartwood only ⁽³⁾ and of durability class 1 – 2 ⁽⁴⁾ .
Timber in contact with the ground	Timber retaining walls up to 1m high and within garden areas ⁽⁷⁾	4	15	✓	✗	✗	✗	Where timber used is heartwood only ⁽³⁾ and of durability class 1 – 2 ⁽⁴⁾ .
Timber in contact with the ground	Timber retaining walls greater than 1m high and within garden areas ⁽⁷⁾	4	30	✓	✗	✗	✗	Where timber used is heartwood only ⁽³⁾ and of durability class 1 ⁽⁴⁾ .
Timber in contact with the ground	Timber retaining walls up to 600mm high and in a boundary situation ⁽⁹⁾	4	30	✓	✗	✗	✗	Where timber used is heartwood only ⁽³⁾ and of durability class 1 ⁽⁴⁾ .

Notes

1. Preservative treatment of timber should be in accordance with the recommendations of BS 8417:2011+A1:2014, Table 4.
2. Preservative treatment of timber should be in accordance with the recommendations of BS 8417:2011+A1:2014, Table 5.
3. Almost always, packs of timber contain sapwood. It should be assumed that timber is sapwood and preservative treated accordingly unless the timber has been specifically selected as heartwood only.
4. Natural durability classes are given in Table 2.
5. Sole plates should be positioned above DPC. Preservatives used should be resistant to leaching or, for boron, treatment should be to full cross-section retention standard. Treatment should be carried out in accordance with BS 8417.
6. The hardwoods known as Meranti, Seraya or Lauan should be treated in the same way as European redwood / Scots Pine when used for joinery.
7. The pressure treatment process used for these types of preservative will cause timber to swell, so these treatments are generally not used for window or door frames and other uses where dimensional precision is required.
8. Decking that is more than 600mm in height should have a desired service life of 60 years. Reference should be made to Chapters 7.1 'Flat roofs and balconies' and 10.2 'Drives, paths and landscaping'.
9. Where timber structures more than 600mm high are used for retaining ground in boundary situations, they should be designed with a desired service life of 60 years. Reference should be made to Chapter 10.2 'Drives, paths and landscaping'.

Table 2: Natural durability of building timbers (heartwood only)

Durability class	1. Very durable	2. Durable	3. Moderately durable	4. Slightly durable	5. Not durable
Hardwoods	<ul style="list-style-type: none"> ■ Kapur (Sabah, Burma) ■ Padauk (white, Andaman) ■ Teak (Malaysian) ■ Opepe ■ Afromosia ■ Greenheart ■ Guarea ■ Iroko ■ Jarrah ■ Okan ■ Pyinkado ■ Peroba 	<ul style="list-style-type: none"> ■ Oak (American white, European) ■ Mahogany (American) ■ Chestnut (sweet) ■ Louro (red) ■ Basralocus ■ Ekki ■ Karri ■ Kempas 	<ul style="list-style-type: none"> ■ Keruing (Sabah, Malaysian) ■ Oak (Tasmanian, Turkey) ■ Mahogany (African) 	<ul style="list-style-type: none"> ■ Oak (American red) ■ Elm (Dutch, English, white, rock, wych) ■ Beech (silver) 	<ul style="list-style-type: none"> ■ Birch (silver, European, paper, yellow) ■ Chestnut (European horse) ■ Beech (European) ■ Sycamore ■ Alder ■ Lime

Table 2 (continued): Natural durability of building timbers (heartwood only)

Durability class	1. Very durable	2. Durable	3. Moderately durable	4. Slightly durable	5. Not durable
Softwoods	None	<ul style="list-style-type: none"> ■ Cedar (imported western red) 	<ul style="list-style-type: none"> ■ Larch (European, hybrid, Japanese, tamarack, western, maritime) ■ Fir (North American Douglas, UK Douglas) ■ Pine (Caribbean pitch, American pitch) ■ Cedar (UK western red) 	<ul style="list-style-type: none"> ■ Pine (Canadian red, Corsican, jack, parana, ponderosa, radiata, Scots, southern, western white, yellow, lodgepole) ■ Spruce (Eastern Canadian, Engelmann, European whitewood, Sitka, western white) ■ Fir (noble, silver, balsam, grand) ■ Hem-fir (USA and Canada) ■ Redwood (European) 	None

3.3.3 Sitework

Sitework shall follow established good practice and workmanship.

Checks should ensure that, when timber is delivered to site, timber and joinery products have received the specified treatment. This should be stated on the delivery note.

3.3.4 Protection and storage

Timber and joinery shall be stored and protected to ensure it is in a suitable condition for use.

It is important when timber and joinery products are stored that they are:

- protected from damage immediately upon delivery
- protected from the weather
- stored off the ground
- stored to limit the risk of distortion
- stored to allow air to circulate.

3.3.5 Treatment of cut surfaces

Timber which has been preservative treated and cut shall be retreated on the cut surfaces.

Timber should not be cut after treatment, but where this is unavoidable, all such surfaces should be retreated with a suitable colour tinted preservative, to enable confirmation that re-treatment has occurred. Only in situations where colour tinting will affect the appearance of the timber fixed to the home will clear preservatives be acceptable.

Applied preservatives should be compatible with the original treatment.

3.3.6 Compatibility with metal

Measures shall be taken to prevent adverse effects from incompatibility between metal components and treated timber.

Copper-containing treatments can cause corrosion between mild steel and aluminium. Where moisture is expected, the following fittings should be used when in contact with timber treated with copper-containing preservatives:

- occasional dampness – galvanised fittings.
- likely wetting – austenitic stainless steel fittings.

Timber treated with copper containing preservatives should be re-dried to a moisture content of 20% for at least seven days before being in contact with metal fittings.

3.3.7 Further information

- *BS 8417 'Preservation of wood. Code of practice'*
- *BS EN 599 – Part 1 'Durability of wood and wood-based products – Efficacy of preventive wood preservatives as determined by biological tests. Specification according to use class'*
- *Part 1: 'Specification according to hazard class. Industrial Wood Preservation – Specification and Practice' ('WPA Manual') (2008)*
- *The Wood Protection Association, 5C Flemming Court, Castleford, West Yorkshire, WF10 5HW, UK, Tel: 01977 558274, Email: info@wood-protection.org*